

OCTOBER 1984 \$1.95  
\$2.50 CANADIAN

# POPULAR COMMUNICATIONS

## Soviet Mystery Ships: Let's Eavesdrop On Them!

- Germany's High Power USA Spy Station
- Broadcasting In Strife-Torn Lebanon
- The U.S. Army Satellite Agency
- Radio Venceremos: Rebel Broadcaster
- Radio History Via Picture Postcards
- Monitoring "Top Band"—A Real Mystery
- What Does "CW" Really Mean?
- Stereo TV Processing
- Eavesdrop On Scanner
- "Splinter Offset Frequencies"





# KENWOOD

...pacesetter in amateur radio

## R-11 portable receiver

### R-11

Kenwood's R-11 is the perfect "go anywhere" portable receiver. It covers the standard AM and FM Broadcast bands, plus nine additional short wave bands. The R-11's selectivity is greatly enhanced by the use of double-conversion on short wave frequencies above 5.95-MHz. High sensitivity coupled with a dual antenna system (telescopic and ferrite core) allow it to

reach out and bring in those distant stations from all over the world.

Simplicity of operation is enhanced by a band-spread type tuning control. Electronic band switching, with LED band indicator, along with a tuning meter to indicate received signal strength, combine to provide you with superior listening capability. Safety Hold-Release switch prevents accidental station loss. Large front mounted speaker provides excellent sound quality. Tone switch adjusts for high, low and voice transmission.

Optional HS-7 micro-head phones allow for private listening pleasure.

All this along with a record output jack, external antenna terminal and a rugged and attractive carrying case make the R-11 portable receiver the perfect travel companion!

More information on the Kenwood receivers is available from authorized dealers of Tric-Kenwood Communications 1111 West Walnut Street, Compton, CA 90220.

CIRCLE 77 ON READER SERVICE CARD



**R-2000** Top-of-the-line general coverage receiver • 150 kHz to 30 MHz • Ten memories • Dual 24-hr clock with timer • Scanning • 100-240 VAC (Opt. 13.8 VDC) • Opt. VHF (118-174 MHz converter).



**R-1000** High performance receiver • 200 kHz - 30 MHz • digital display/clock/timer • 3 IF filters • PLL UP conversion • noise blanker • RF step attenuator • 120-240 VAC (Optional 13.8 VDC).



**R-600** General coverage receiver • 150 kHz - 30 MHz • digital display • 2 IF filters • PLL UP conversion • noise blanker • RF attenuator • front speaker • 100-240 VAC (Optional 13.8 VDC).







# SCANNER WORLD, USA

10 New Scotland Ave., Albany, NY 12208 518/436-9606

# special The Regency D310

## 30 Channel Automatic/Programmable Scanner

### FEATURES

- **30 Channels** For full coverage and easy selection.
- **No Crystals Required** Your choice of over 15,000 frequencies just by pushing a button.
- **6 Bands** Covers high and low VHF, UHF and UHF "T" plus two FM Ham Bands.
- **Search or Scan** Scan frequencies you have entered or search for exciting new frequencies.
- **Priority Control** Automatically overrides all other calls to listen to your favorite frequency.
- **Permanent Backup System** Memory requires no batteries. Capacitor saves frequencies entered up to one week during power outage or storage.
- **Dual Level Display** Selects brightness level of vacuum fluorescent digital display.
- **Channel Lockout** Skips channels not of current interest.
- **Scan Delay** Lets you set a delay so that replies to calls will be heard before scanning resumes.
- **Display Messages** Display flashes verbal messages to aid in programming.
- **External Speaker Jack** Standard connection allows use of external speaker.
- **AC or DC** Use at home or on the go. Both power cords included.

### Scanner World Price

# \$129.99

(plus 4.50 Shipping)

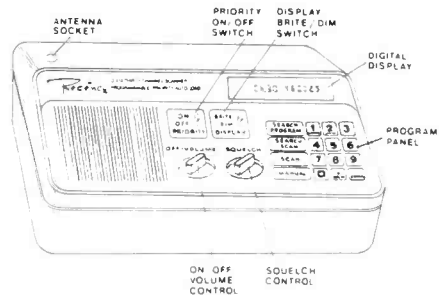

### Suggested Factory List Price \$259.95

The Regency D310 is a compact, programmable 30 channel, multi band, FM monitor receiver for use at home or on the road. It is double conversion, superheterodyne used to receive the narrow band FM communications in the amateur, public safety and business bands: 30-50, 144-174, and 440-512 MHz.

Sophisticated microprocess-controlled circuitry eliminates the need for crystals. Instead, the frequency for each channel is programmed through the numbered keyboard similar to the one used on a telephone. A "beep" acknowledges contact each time a key is touched. The D310 scans approximately 15 channels per second.

Any combination of two to thirty channels can be scanned automatically, or the unit can be set on manual for continuous monitoring of any one channel. In addition, the search function locates unknown frequencies within a band.

Other features include scan delay, priority and a bright/dim switch to control the brightness of the 9-digit Vacuum-Fluorescent display. The D310 can be operated on either 120VAC or 12VDC. One year warranty from Regency Electronics.

- **Telescoping Antenna** Electronically optimized for all frequencies. included.
- **External Antenna Jack** Permits maximum reception range.
- **UL Listed/FCC Certified** Assurance of quality, American made design and manufacture.

**Optional Mobile Cigarette Lighter Plug (RGMPC . . . 4.95)**

### REGENCY D310 only

# \$129.99

(plus 4.50 Shipping)

REGENCY D-310 30 Channel Digital	129.99(4.50)
REGENCY MA-506 Carry Case for HX-650 & H-604	12.99 (*)
REGENCY ACT-R2AP Aircraft Crystal	119.99 (4.00)
REGENCY POLARIS MT-5500XL Marine	214.99 (5.50)
REGENCY R1050 AC 10 Chan. Programmable	116.99 (4.00)
REGENCY C403 AC 4 Channel Crystal HLU	66.99 (4.00)
REGENCY Z-30 — 30 Channel Digital	172.99 (4.00)
REGENCY Z-10 — 10 Channel Digital	146.99 (4.00)
REGENCY MX5000 All Band Scanner	369.99 (5.50)
REGENCY D100 10 Channel Digital	138.99 (4.00)
REGENCY MX3000 30 Channel Digital	186.99 (4.00)
RCD Listen-In	38.99 (3.00)
REGENCY R106 AC/DC 10 Chan. HLU Crystal	96.99 (4.00)
REGENCY D810 AC 50 Chan. HLU & Air Digit.	249.99 (4.00)
JIL SX-100 16 Channel Scanner	159.99 (4.00)
JIL SX-200 16 Channel Scanner	269.99 (4.00)
RUSSELL Digi-10 Russcan Hi/Lo Handheld	114.99 (3.00)
FANON M8HLU 8 Chan. Mini Mobile Crystal	99.99 (4.00)
FANON PSK-1 AC adapter for M8HLU	12.99 (*)
FANON SlimLine 6 HLU Handheld Crystal Scanner	103.99 (4.00)
FANON CHB-6 Charter/AC Adpater for Slim 6	12.99 (*)
FANON CAT-6 Carrying Case with Belt Clip	11.99 (*)
FANON AUC-3 Autolighter Adapter/Charger	12.99 (*)
FANON SCMA-6 Mobile Adapter/Charger/Amplifier for Slim Line 6 HLU	38.99 (3.00)
FANON PSK-6 Base Power Supply for SCMA-6	14.99 (*)
BEARCAT 350 AC/DC 50 Channel	394.99 (5.50)
BEARCAT 5 HLU AC Crystal Scanner	94.99 (4.00)
BEARCAT FIVE-SIX Pocket Scanner	126.99 (4.00)
BEARCAT SP-55 Carry Case for BC5/6	12.99 (*)
BEARCAT BC-260 AC/DC Scanner	278.99 (4.00)
BEARCAT DX-1000 Shortwave Radio	499.99 (12.00)
BEARCAT 20/20 Digital Scanner	279.99 (4.00)
BEARCAT 220 Digital Scanner	249.99 (4.00)
BEARCAT 250 Digital Scanner	265.99 (4.00)
BEARCAT 100 Digital Hand-Held	284.99 (5.50)
BEARCAT 300 Digital Scanner	346.99 (5.50)
BEARCAT 201 Digital Scanner	194.99 (4.00)
BEARCAT 180 Digital Scanner	168.99 (4.00)
BEARCAT 210 XL Digital Scanner	224.99 (4.00)

BEARCAT 15 Crystal Scanner	126.99 (4.00)
REGENCY RH-250 High Band 2-way Radio	479.99 (5.50)
REGENCY Z100 watt High Band Amplifier	209.99 (4.00)
JIL SX-400 All Band DC Scanner	549.99 (12.00)

Uniden/President CB Radios - All Models in Stock  
Fox & Whistler Radar Detectors - In Stock

### Super Special Package Sale!

## REGENCY HX-650

Pocket Scanner

6 CHANNELS — 4 BANDS

VHF-Low	30 to 50 MHz
VHF-High	146 to 174 MHz
UHF	450 to 470 MHz
UHF-T	470 to 512 MHz
Small Size	3 3/4" W x 5 1/2" H x 1" D

Quality features included in the Regency HX-650 are 6 channels - 4 band coverage, lockout switches, manual step switch, scanning speed of 15 channels per second, long lasting LED's, volume & squelch controls, AC adapter/charger jacks.

### Scanner World's Special Package Deal

Includes the following:

- Regency HX-650 Pocket Scanner
- MA-506 Carry Case with metal belt clip
- Set of 4 AAA Nickel Cadmium Batteries
- 6 Monitor Crystals (specify frequencies needed or will include certificates for unknown frequencies)
- Flexible Rubber Duckey Antenna
- AC Adapter & Charger

### Scanner World Package Price

# \$109.99

(Plus \$5.50 Shipping)



### Ordering Information

Call (518) 436-9606 to place orders by phone or mail orders to **Scanner World**, 10 New Scotland Ave, Albany, NY 12208. Orders will be shipped same day received by United Parcel Service. **Scanner World** accepts VISA, MasterCard. C.O.D. shipments by United Parcel will be for cash or certified checks only. Mail orders with personal or business checks will be held 4 weeks for bank clearance. Orders with cashiers checks or money orders shipped same day received. Prices, specifications and terms subject to change without prior notice. If items are out of stock we will backorder and notify you of delivery date. All shipments are F.O.B. **Scanner World** warehouse in Albany, NY. We are not responsible for typographical errors. All merchandise carries full manufacturers warranty. Bid Proposals and Purchase Orders accepted from Government agencies. Free full line catalogue available upon request. No minimum order. New York State Residents add 7% sales tax. Dealers send business letterhead for dealer wholesale information.

### Shipping Charges

Add (\$) per scanner, and \$3.00\* for all accessories ordered at same time. C.O.D. shipments will be charged an additional \$3.00 per package. Full insurance is included in shipping charges. All orders are shipped by United Parcel Service. Shipping charges are for continental USA only. Outside of continental USA, add \$15.00 per scanner.

### Scanner World, USA

10 New Scotland Ave, Albany, NY 12208

(518) 436-9606

CIRCLE 52 ON READER SERVICE CARD

# NEW!

# uniden®

# Bearcat®

# Products

Communications Electronics™, the world's largest distributor of radio scanners, is pleased to announce that Bearcat brand scanner radios have been acquired by Uniden Corporation of America. Because of this acquisition, Communications Electronics will now carry the complete line of Uniden Bearcat scanners, CB radios and Uniden Bandit™ radar detectors. To celebrate this acquisition, we have special pricing on the Uniden line of electronic products.

## Bearcat® 300-E

List price \$549.95/CE price \$339.00  
**7-Band, 50 Channel • Service Search • No-crystal scanner • AM Aircraft and Public Service bands. • Priority Channel • AC/DC**  
 Bands: 32-50, 118-136 AM, 144-174, 421-512 MHz. The Bearcat 300 is the most advanced automatic scanning radio that has ever been offered to the public. The Bearcat 300 uses a bright green fluorescent digital display, so it's ideal for mobile applications. The Bearcat 300 now has these added features: Service Search, Display Intensity Control, Hold Search and Resume Search keys, Separate Band keys to permit lock-in/lock-out of any band for more efficient service search.

## Bearcat® 20/20-E

List price \$449.95/CE price \$269.00  
**7-Band, 40 Channel • Crystalless • Searches AM Aircraft and Public Service bands • AC/DC Priority Channel • Direct Channel Access • Delay**  
 Frequency range 32-50, 118-136 AM, 144-174, 420-512 MHz. Find an easy chair. Turn on your Bearcat 20/20 and you're in an airplane cockpit. Listening to all the air-to-ground conversations. Maybe you'll pick up an exciting search and rescue mission on the Coast Guard channel. In a flash, you're back on the ground listening as news crews report a fast breaking story. Or hearing police and fire calls in your own neighborhood, in plenty of time so you can take precautions. You can even hear ham radio transmission, business phone calls and government intelligence agencies. Without leaving your easy chair. Because you've got a Bearcat 20/20 right beside it.

The Bearcat 20/20 monitors 40 frequencies from 7 bands, including aircraft. A two-position switch, located on the front panel, allows monitoring of 20 channels at a time.

## Bearcat® 210XL-E

List price \$349.95/CE price \$209.00  
**6-Band, 18 Channel • Crystalless • AC/DC**  
 Frequency range 32-50, 144-174, 421-512 MHz. The Bearcat 210XL scanning radio is the second generation scanner that replaces the popular Bearcat 210 and 211. It has almost twice the scanning capacity of the Bearcat 210 with 18 channels plus dual scanning speeds and a bright green fluorescent display. Automatic search finds new frequencies. Features scan delay, single antenna, patented track tuning and more.

## Bearcat® 260-E

List price \$399.95/CE price \$249.00  
**8-Band, 16 Channel • Priority • AC/DC**  
 Frequency range 30-50, 138-174, 406-512 MHz. Keep up with police and fire calls, ham radio operators and other transmission while you're on the road with a Bearcat 260 scanner. Designed with police and fire department cooperation, its unique, practical shape and special two-position mounting bracket makes hump mounted or under dash installation possible in any vehicle. The Bearcat 260 is so ruggedly built for mobile use that it meets military standard 810c, curve y for vibration rating. Incorporated in its rugged, all metal case is a specially positioned speaker delivering 3 watts of crisp, clear audio.

## NEW! Bearcat® 201-E

List price \$279.95/CE price \$179.00  
**9-Band, 16 Channel • Crystalless • AC only Priority • Scan Delay • One Key Weather**  
 Frequency range 30-50, 118-136 AM, 146-174, 420-512 MHz. The Bearcat 201 performs any scanning function you could possibly want. With push button ease, you can program up to 16 channels for automatic monitoring. Push another button and search for new frequencies. There are no crystals to limit what you want to hear.

## NEW! Bearcat® 180-E

List price \$249.95/CE price \$149.00  
**8-Band, 16 Channel • Priority • AC only**  
 Frequency range: 30-50, 138-174, 406-512 MHz. Police and fire calls. Ham radio transmissions. Business and government undercover operations. You can hear it all on a Bearcat 180 scanner radio. Imagine the thrill of hearing a major news event unfold even before the news organizations can report it. And the security of knowing what's happening in your neighborhood by hearing police and fire calls in time to take precautions. There's nothing like scanning to keep you in-the-know, and no better way to get scanner radio performance at a value price than with the Bearcat 180.

## Bearcat® 100-E

**The first no-crystal programmable handheld scanner.**  
 List price \$449.95/CE price \$234.00/SPECIAL!  
**8-Band, 16 Channel • Liquid Crystal Display Search • Limit • Hold • Lockout • AC/DC**  
 Frequency range: 30-50, 138-174, 406-512 MHz. The world's first no-crystal handheld scanner has compressed into a 3" x 7" x 1 1/4" case more scanning power than is found in many base or mobile scanners. The Bearcat 100 has a full 16 channels with frequency coverage that includes all public service bands (Low, High, UHF and "T" bands), the 2-Meter and 70 cm. Amateur bands, plus Military and Federal Government frequencies. It has chrome-plated keys for functions that are user controlled, such as lockout, manual and automatic scan. Even search is provided, both manual and automatic. Wow...what a scanner!

The Bearcat 100 produces audio power output of 300 milliwatts, is track-tuned and has selectivity of better than 50 dB down and sensitivity of 0.6 microvolts on VHF and 1.0 microvolts on UHF. Power consumption is kept extremely low by using a liquid crystal display and exclusive low power integrated circuits.

Included in our low CE price is a sturdy carrying case, earphone, battery charger/AC adapter, six AA ni-cad batteries and flexible antenna. The Bearcat 100 is in stock for quick shipment, so order your scanner today.

## Bearcat® DX1000-E

List price \$649.95/CE price \$489.00  
 Frequency range 10 kHz to 30 MHz.  
 The Bearcat DX1000 shortwave radio makes tuning in London as easy as dialing a phone. It features PLL synthesized accuracy, two time zone 24-hour digital quartz clock and a built-in timer to wake you to your favorite shortwave station. It can be programmed to activate peripheral equipment like a tape recorder to record up to five different broadcasts, any frequency, any mode, while you are asleep or at work. It will receive AM, LSB, USB, CW and FM broadcasts.

There's never been an easier way to hear what the world has to say. With the Bearcat DX1000 shortwave receiver, you now have direct access to the world.

## Uniden® PC22-E

List price \$159.95/CE price \$99.00  
 The Uniden PC22 is a 40 channel AM remote mobile CB radio. It's the answer for today's smaller cars which don't always provide adequate space for mounting. Since all the controls are on the microphone, you can stash the "guts" in the trunk. The microphone has up/down channel selector, digital display, TX/RX indicator and external speaker jack. Dimensions: 5 3/4" W x 7 7/8" D x 1 1/2" H. 13.8 VDC, positive or negative ground.

**QUANTITY DISCOUNTS AVAILABLE**  
 Order two scanners at the same time and deduct 1%, for three scanners deduct 2%, four scanners deduct 3%, five scanners deduct 4% and six or more scanners purchased at the same time earns you a 5% discount off our super low single unit price.

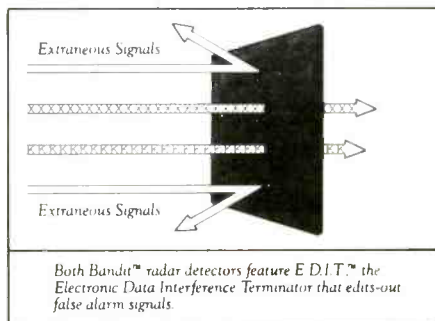

## Uniden® PC33-E

List price \$59.95/CE price \$44.00  
 The Uniden PC33 boasts a super-compact case and front-panel mike connector to fit comfortably in today's smaller cars. Controls: Power & Volume, Squelch; Switches: ANL, PA-CB, Channel 9 and RF Gain switches. LED "S"/RF Meter, Digital channel indicator. Dimensions: 6" W x 6" D x 1 1/8" H. ±13.8 VDC.

## Uniden® PC55-E

List price \$89.95/CE price \$59.00  
 The full featured Uniden PC55 front-panel mike connector makes installation easier when space is a factor. It has ANL, PA-CB, Channel 9 and RF Gain switches. LED "S"/RF meter, TX lite, PA & external speaker jacks. Dimensions: 6" W x 6" D x 1 1/8" H. ±13.8 VDC.

## Bandit™ Radar Detectors

Now that everyone else has taken their best shot at radar detection, the Uniden Bandit™ has done them one better...with E.D.I.T.™, the Electronic Data Interference Terminator that actually edits-out false alarm signals.

The Bandit 55, features a convenient brightness/dimmer control for comfortable day or night driving, plus a handy highway/city control for maximum flexibility wherever you drive. The Bandit 95 Remote, is a two-piece modular unit that lets you mount the long-range radar antenna behind the grill, out of view. The ultra-compact control unit can then be inconspicuously tucked under the dash or clipped to the visor. Order Bandit 55-E for \$119.00 each or the Bandit 95-E Remote for \$139.00 each.

**OTHER RADIOS AND ACCESSORIES**  
 FB-E-E Frequency Directory for Eastern U.S.A. .... \$12.00  
 FB-W-E Frequency Directory for Western U.S.A. .... \$12.00  
 BC-WA-E Bearcat Weather Alert ..... \$35.00  
 A60-E Magnet mount mobile antenna ..... \$35.00  
 A70-E Base station antenna ..... \$35.00  
 Add \$3.00 shipping for all accessories ordered at the same time.  
 Add \$3.00 shipping per scanner antenna.

## BUY WITH CONFIDENCE

To get the fastest delivery from CE of any product in this ad, send or phone your order directly to our Scanner Distribution Center™. Michigan residents please add 4% sales tax or supply your tax I.D. number. Written purchase orders are accepted from approved government agencies and most well rated firms at a 10% surcharge for net 10 billing. All sales are subject to availability, acceptance and verification. All sales on accessories are final. Prices, terms and specifications are subject to change without notice. All prices are in U.S. dollars. Out of stock items will be placed on backorder automatically unless CE is instructed differently. A \$5.00 additional handling fee will be charged for all orders with a merchandise total under \$50.00. Shipments are F.O.B. Ann Arbor, Michigan. No COD's. Most products that we sell have a manufacturer's warranty. Free copies of warranties on these products are available prior to purchase by writing to CE. International orders are invited with a \$20.00 surcharge for special handling in addition to shipping charges. Non-certified checks require bank clearance.

Mail orders to: Communications Electronics™, Box 1002, Ann Arbor, Michigan 48106 U.S.A. Add \$7.00 per scanner, radar detector or CB or \$12.00 per shortwave receiver for U.P.S. ground shipping and handling in the continental U.S.A. For Canada, Puerto Rico, Hawaii, Alaska, or APO/FPO delivery, shipping charges are three times continental U.S. rates. If you have a Visa or Master Card, you may call and place a credit card order. Order toll-free in the U.S. Dial 800-521-4414. In Canada, order toll-free by calling 800-221-3475. WUI Telex CE anytime, dial 671-0155. If you are outside the U.S. or in Michigan dial 313-973-8888. Order today.

Scanner Distribution Center™ and CE logos are trademarks of Communications Electronics™. Ad # 070184-E † Bearcat is a registered trademark of Uniden Corporation. Copyright © 1984 Communications Electronics

Order Toll Free ... call  
**1-800-521-4414**

**COMMUNICATIONS ELECTRONICS™**

**Consumer Products Division**

818 Phoenix □ Box 1002 □ Ann Arbor, Michigan 48106 U.S.A.  
 Call TOLL-FREE 800-521-4414 or outside U.S.A. 313-973-8888



**EDITORIAL STAFF**Tom Kneitel, K2AES  
EditorAnita Hipius  
Associate Editor**CONTRIBUTING EDITORS**Gerry L. Dexter  
Shortwave BroadcastJoseph E. Jesson  
RTTY MonitoringR.L. Slattery  
Survivalist CommunicationsRon Ricketts, WA5VFA  
Utility CommunicationsDarren Leno, W0EWJ  
Alternative RadioHarold A. Ort, Jr.  
Military ConsultantJanice Lee  
Radar DetectorsChuck Gysi, N2DUP  
ScannersFrank Baylin  
Satellite TVGordon West, WB6NOA  
Telephone AccessoriesMark J. Manucy, W3GMG  
AM/FM Broadcasts**BUSINESS STAFF**Richard A. Ross, K2MGA  
PublisherHerb Pressman, KA2UGV  
Advertising ManagerArnold Sposato, KA2TYA  
Advertising RepresentativeDorothy Kehrwierder  
General ManagerAnthony C. Sparacino  
Newsstand Sales DirectorArlene Caggiano  
AccountingCheryl Chomicki  
Subscriber Services**PRODUCTION STAFF**Elizabeth Ryan  
Art DirectorDorothy Kehrwierder  
Production ManagerGail M. Schieber  
Production AssistantPat Le Blanc  
PhototypographerHal Keith  
Technical IllustratorLarry Mulvehill, WB2ZPI  
Contributing Photographer

# POPULAR COMMUNICATIONS

**OCTOBER 1984****VOL. 3, NO.2**

24

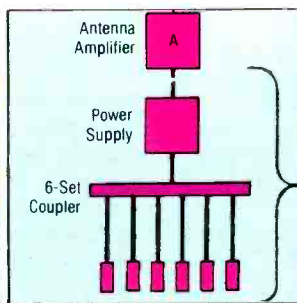

32

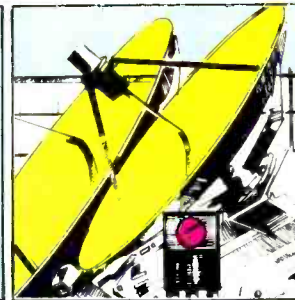

44

**FEATURES****How To Monitor Soviet Mystery Ships**

8

Spy ships, the Soviet Navy, fishing trawlers, and the rest—the bottom line is that there may not be much difference between them! Monitoring them isn't as difficult as you may think. Here's how to tune in on them!

by Harry Caul, K1L9XL

**Torn Fabric: Radio In Lebanon**

12

One of the world's hottest hot spots is actually divided into many segments, each with its own political and religious viewpoint to tell you about.

by Gerry L. Dexter

**Germany's High Power Spy Station — In The USA!**

16

Did our government conveniently look the other way while it operated? Could Uncle Sam have prevented one of the most famous sea disasters of all time by pulling the plug on this station? And what about the curious code sending machine? There are many unanswered questions almost 70 years later!

by Tom Kneitel, K2AES

**"We Will Win"**

24

Radio Venceremos: Here's an inside look at one of today's most vocal and influential rebel broadcasters and the way it operates.

by Owen Williamson

**Radio History — Via Picture Postcards**

28

Here's an inexpensive and fun way to look back into old time broadcasting history and see what stations looked like in "The Golden Era."

by Alice Brannigan

**DXing The "Top End"**

38

The 1600 to 1800 kHz band. In a radio spectrum reaching towards microwaves and beyond, this portion of the spectrum (adjacent to the AM broadcast band) is vital, exciting, and just plain wild!

by Harry Helms, KR2H

**Dig Those Army Birds**

44

The U.S. Army Satellite Communications Agency. Here's a military communications agency that may have escaped your attention. Now you know about it.

**"DAH-DI-DAH"**

49

Just what does "CW" stand for? Some folks say that it stands for a whole lot and gets right down into the traditional roots of communicating. Here are some thoughts on how this affects you.

by W. Clem Small, KR6A

**Books You'll Like**

72

Here's a new book that tells you all about getting the most from a VCR, along with another exciting book about monitoring the secret shortwave spectrum.

*This month's cover: Soviet destroyer in the Caribbean en route to Cuba. Photo by D. Hamilton, Jr., SYGMA.*

**DEPARTMENTS**

Beaming In . . . . .	4	Pirates Den . . . . .	54
Mailbag . . . . .	6	RTTY Monitoring . . . . .	58
Survival . . . . .	30	POP'COMM Products . . . . .	60
Broadcast Topix . . . . .	32	Communications Confidential . . . . .	62
Scanner Scene . . . . .	36	Radar Reflections . . . . .	66
Listening Post . . . . .	40	Washington Pulse . . . . .	68
On The Line . . . . .	46	Communications Shop . . . . .	74
Satellite View . . . . .	51		

Offices: 76 North Broadway, Hicksville, NY 11801. Telephone 516 681-2922. Popular Communications (ISSN 0733-3315) is published monthly by Popular Communications, Inc. Corporate officers: Richard A. Ross, Pres.; Thomas S. Kneitel, Vice Pres.; Alan M. Dorhoffer, Secretary. Second class postage paid at Hicksville, NY and additional offices. Subscription prices: Domestic—one year \$14.00, two years \$25.00, three years \$36.00. Canada/Mexico—one year \$16.00, two years \$29.00, three years \$42.00. Foreign—one year \$18.00, two years \$33.00, three years \$48.00. Foreign Air Mail—one year \$71.00, two years \$139.00, three years \$207.00. Entire contents copyright ©1984 by Popular Communications, Inc. Popular Communications assumes no responsibility for unsolicited manuscripts, photographs, or drawings. Allow six weeks for change of address or delivery of first issue. Printed in the United States of America. Postmaster: Please send change of address to Popular Communications, 76 North Broadway, Hicksville, NY 11801.

## RECEIVE RTTY/ASCII/CW on your Personal Computer



**RTTY/ASCII/CW  
SWL COMPUTER INTERFACE** MFJ-1225  
\$ **69.95**

**FREE MFJ RTTY/ASCII/CW Software**  
TAPE AND CABLE FOR VIC-20 OR C-64. ORDER MFJ-1225/  
MFJ-1264 FOR VIC-20 OR MFJ-1225/MFJ-1265 FOR C-64.

Receives commercial, military, and amateur RTTY/ASCII/CW using your personal computer.

The MFJ-1225 Computer Interface plugs between your receiver and VIC-20, Apple, TRS-80C, Atari, TI-99, Commodore 64 and most other personal computers. Requires appropriate software.

Copies all shifts (850, 425, 170 Hz shift and all others) and all speeds. Automatic noise limiter suppresses static crashes for better copy. 2 LED tuning indicator makes tuning fast, easy, positive. 4 1/2 x 1 1/4 x 4 1/4 in. 12-15 VDC or 110 VAC with optional adapter, MFJ-1312, \$9.95.

### INDOOR TUNED ACTIVE ANTENNA

MFJ-1020  
\$ **79.95**



MFJ-1020 New Indoor Active Antenna sits on your desk ready to listen to the world. Rivals, often exceeds, reception of outside long wire. Unique Tuned Active Antenna minimizes intermode, provides RF selectivity, reduces noise outside tuned band. Also use as preselector for external antenna. Covers 300 KHz to 30 MHz in 5 bands. Adjustable telescoping antenna. Controls: Tune, Band Selector, Gain, ON-Off/Bypass, LED. FET, bipolar circuitry. Phonojack for external ant. 6x2x6 in. 9-18 VDC or 9V battery. 110 VAC with adapter, MFJ-1312, \$9.95.

### REMOTE ACTIVE ANTENNA

54 inch remote active antenna mounts outdoor away from electrical noise for maximum signal and minimum noise pickup. Often outperforms longwire hundreds of feet long. Mount anywhere - atop houses, buildings, balconies, apartments, mobile homes, on board ship.

Uses with any radio to receive strong clear signals from all over the world. 50 KHz to 30 MHz.

High dynamic range eliminates intermodulation. Inside control unit has 20 dB attenuator, gain control. Switch 2 receivers and auxiliary or active antenna. "On" LED. 6x2x5 in. 50 ft. coax. 12 VDC or 110 VAC with MFJ-1312, \$9.95.



MFJ-1024  
\$ **129.95**

Order from MFJ and try it. If not delighted, return within 30 days for refund (less shipping).

One year unconditional guarantee.

Order yours today. Call toll free 800-647-1800. Charge VISA, MC. Or mail check, money order. Add \$4.00 each for shipping and handling.

**CALL TOLL FREE ... 800-647-1800**

Call 601-323-5869 in Miss., outside continental USA, tech/order/repair info. TELEX 53-4590

**MFJ ENTERPRISES,  
INCORPORATED**  
Box 494, Mississippi State, MS 39762

CIRCLE 64 ON READER SERVICE CARD

# BEAMING IN

AN EDITORIAL

BY TOM KNEITEL, K2AES

## Getting Clubbed

**M**ake no mistake about it—taking positions on things and expounding opinions isn't without very predictable reactions. There are all sorts of tigers (paper and otherwise) sitting out there in readerland just waiting to spring into action at the slightest provocation. From speaking to other editors, I get the impression that in every possible area to which a magazine might be directed there are certain topics that are not only volatile but which need be referred to with no more than a word or two before the mail comes pouring in, much of it expressing violent emotional reactions which generally fall into several specific categories: 1) extreme delight that the topic was mentioned; 2) total outrage that the topic was mentioned; 3) shock that the topic was given so little exploration since it is so important.

Within our coverage here at POP'COMM, some of the things which call out the troops include pirate radio, radar detectors, Tesia, the Voice of America, and SWL radio clubs. As I said, the mere mention of any of these things triggers an avalanche of mail and controversy. It should be considered, however, that I like getting mail, and controversy is not a matter with which I am unfamiliar nor is it something from which I flee in horror. The fact is, a bit of controversy from time to time is probably good for body, mind, and soul. Not that I go out of my way to generate controversy, it's just something that seems to pop up in the normal course of expressing my opinions. On the other hand, there are things which do seem to cry out for discussion at times and there aren't very many people who appear to be willing to address these topics.

At least once every year or so I get around to mentioning SWL radio clubs; this year's time is now. If you're one of those people who can't handle opinions on radio clubs, be forewarned that it's time to make certain you know the location of the Pepto Bismol, the Excedrin, some writing paper, an envelope, and a stamp before proceeding down this page.

The concept of having radio clubs for listeners goes back to the 1920's and groups such as the National Radio Club and the late (lamented) Newark News Radio Club. Since that time, clubs have provided (or attempted to provide) news regarding station activities. Club newsletters can get late-breaking information to members very quickly and therein is one of their main advantages. This is not a process which is as easy as it might sound and has been the cause for an almost endless parade of clubs in the process of either coming into or else going out of existence. Rare indeed are the clubs which have been able to remain viable over an extended period of

time. There are definite problems. One problem, for instance, is that while ham radio and CB clubs tend to remain local or regional in scope, the majority of SWL and monitoring clubs seek to be national or international in scope. Distances between the officers and individual members generate their own difficulties and complications. But these aren't the only problems.

These groups very often get caught up in internal power and heated political struggles, membership cliques, suffer a lack of resources, have difficulties in getting (and keeping) members, have poor (or no) public relations, have no savvy on how to publicize or promote the organization on a national basis, and have too few members who are willing or able to perform any of the many necessary jobs which are required on behalf of the group over an extended period of time. Some clubs also become mired in hassles with equipment manufacturers or dealers, or various DXers or other clubs—a certain path to disaster!

Although there is no reason for clubs to have an adversary relationship with national media, over the years magazine editors have generally written off DX clubs *en masse* as a bunch of strange folks—this after many months of futile attempts at establishing a rapport and working relationship with some of the groups. Curiously, this situation does not exist between magazines and ham or CB clubs. Nevertheless, magazines such as *Popular Electronics*, *Electronics Illustrated*, and *Communications World* (all of which covered monitoring while they were in business) came to believe that SWL clubs were best viewed with a jaundiced eye, or else they were totally ignored. This was a shame because there was a very real opportunity for a good working relationship to exist with benefits to both the clubs and publications. The problem here, as I have seen it, has been a strange and unjustified mistrust, paranoia, or fear about national publications. Quite honestly, some clubs are really their own worst enemies and the sour grapes attitudes on many things has not been of any value in helping them to continue operation.

Going by my past experiences with SWL clubs and monitoring groups, I have attempted to carefully select the groups I believe have done an outstanding job before recommending them to POP'COMM readers. Those groups that have proven to be problem-oriented have mostly been ignored in these pages. In this manner I have sought to avoid resorting to a blanket write-off of all

(Continued on page 73)



# SWL HEADQUARTERS

NATIONS LEADING SHORTWAVE EQUIPMENT SUPPLIER

## ICOM R71A SPECIAL

EEB IS ICOM'S #1 RECEIVER DEALER AND THERE'S GOOD REASON

- **EEB** does 100% QC, including 24 hour bench test and complete alignment.
- **EEB** offers more options and modifications to tailor your receiver to your needs.
- **EEB's** skilled technicians know the R71A inside and out; and offer many optional improvements.
- **EEB** doubles your warranty: 90 days ICOM/90 days **EEB**, so you are covered a full 6 months!
- **EEB** is an authorized ICOM Service center. We take better care of you.



- 100KHz—30MHz
  - Keyboard Entry
  - 32 Memories
  - Memory Back-Up
  - Scanning Frequencies & Memories
  - Passband & Notch Tuning
  - Wide Dynamic Range
- AS LOW AS  
**\$659**  
list \$799
- Add \$7.00 UPS

### OPTIONS

CK-70	12 Volt DC Kit	\$9.95
CR-64	High Stability Osc.	\$56.00
EX-310	Voice Synthesizer	\$39.95
EX-257	FM unit (10M Ham)	\$38.00
FL-32	CW filter, 500Hz 9MHz	\$59.50
FL-44	2.4KHz 455KHz SSB Crystal Filter	\$159.00
FL63	CW filter 250Hz 9MHz	\$48.50
RC-11	Remote Control	\$59.95

INSTALLATION . . . options can be installed by a skilled user/owner. **EEB** will do it for you!

- 1-3 options . . . . . \$ 35
- 4 and up . . . . . \$ 45

### EEB OPTIONS INSTALLED

- **Mechanical 2.4KHz filter**—replaces stock ceramic filter—improves SSB, ECSS, AM narrow selectivity. . . . . \$ 95
  - **Front end upgrade**—improves dynamic range (plus), pre-amp enable below 1600KHz . . . . . \$ 35
  - **4KHz filter** replaces stock 6KHz wide filter. Improves AM selectivity. . . . . \$ 50
- ICOM ICR71A with full **EEB** service . . . . . \$699  
Factory and extended warranty, tested and aligned . . . . .
- ICOM ICR71A with full factory warranty but without **EEB's** extra service/no installed options . . . . . \$659

## \*KENWOOD R-2000



- 100 KHz to 30 MHz
  - All mode AM-CW-SSB-FM
  - 10 memories (memorizes mode)
  - Memory backup
  - Memory scan
  - Programmable band scan
  - 24-hour clock-timer
  - VC-10 VHF converter 118-174 MHz \$139
- Sale \$499**  
List \$599.95
- R-2000 \$599.95 . . . . . SALE \$499  
R-1000 \$499.95 . . . . . SALE \$429  
R-600 \$399.95 . . . . . SALE \$329  
ADD \$6.50 UPS

## \* YAESU FRG-7700



- Sale \$399**
- 150 KHz-30MHz
  - All mode AM-CW-SSB-FM
  - Digital frequency and clock
- SPECIAL PACKAGE DEAL**  
7700-MU7700  
FRA-7700  
499<sup>95</sup>
- Options:
- FRA-7700 active antenna . . . . . \$59
  - MU-7700 12 channel memory . . . . . \$135
  - FRT-7700 antenna tuner . . . . . \$59
  - FF-5 VLF low pass filter . . . . . \$20
  - DC-7700 12 VDC kit . . . . . \$8
  - FRV-7700 VHF converter . . . . . \$135
  - ADD \$6.50 UPS

## \* G.E. WORLD MONITOR



- Sale \$169**  
List \$229.95  
(\$4.00 UPS)
- Digital readout, wide and narrow selectivity BFO for SSB & CW.
- 3.5 - 31 MHz SW/MW/FM
  - 120V/220V or battery

## \* PANASONIC RF-B600

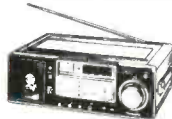

- Sale \$429**  
List \$595  
(\$6.00 UPS)
- 1.6 to 30 MHz, FM/LW/MW/SW
  - Micro computer multi-tuning system
  - 9 memory stations, scan
  - Slow/Fast rotary tuning
  - 10 key direct access tuning
  - Universal voltage
- RF-9 \$99.95 . . . . . SALE \$89.00  
RF-B50 159.95 . . . . . SALE \$129.00  
RF-085 . . . . . CLOSE OUT \$49.95  
RF-B300 \$249.95 . . . . . SALE \$209  
RF-3100 \$379 . . . . . SALE \$279  
ADD \$4.00 UPS

## \* UNIDEN CR 2021



**Sale \$149.95**  
List \$229.00

- Uniden's Worldwide Radio is among the finest multi-purpose available anywhere. It features a triple conversion receiver that precisely locates weak, distant signals automatically. It locks the precise stations in for perfect reception.
  - 12 Channel Programmable Memory
  - Dual Power AC or DC
  - Micro-processor
  - Triple Conversion Receiver
  - Keyboard Channel Selector
  - LCD Readout
  - Preset Channels
- \$4.00 UPS.

## \* SONY ICF-2002



Introductory Special  
**\$229**  
List \$249.95

- Features: Ten memory channels • 12/24 hour quartz clock/PLL tuning for drift-free performance • Dual conversion Super-heterodyne for high sensitivity • SSB/CW
- ICR-4800 \$99.95 . . . . . SALE \$69.95  
ICF-6500W \$199.95 . . . . . SALE \$99.95  
ICF-6800W \$699.95 . . . . . SALE \$549  
ICF-7600A \$169.95 . . . . . SALE \$139

ADD \$4.00 UPS

## NEW From SONY AN-1 WORLD BAND ANTENNA



- Telescoping 59" stainless steel whip
- 100KHz to 30MHz
- Antenna coupler and special induction module supplied
- Control module features attenuator, frequency selector, and battery power

EEB tests indicate AN-1 to work as well as other antennas costing twice as much and less susceptible to overload from strong signals.



**\$79.95**

Optional AC adapter AC-160 . . . . . \$14.95  
EEB AC Adaptor . . . . . \$9.95  
Add \$5.50 UPS.

## FREE CATALOG



- We ship worldwide
- Shipping charges not included
- Prices & specifications subject to change without notice
- Canadian Orders: VISA, MC or POSTAL MAIL ORDERS ONLY!



10 Miles West of Washington, D.C.  
Sorry—No COD's  
10-5 Tues., Wed., Fri.  
10-9 Thursday  
10-4 Saturday  
Closed Sunday and Monday

**Electronic Equipment Bank**  
516 Mill Street, N.E.  
Vienna, Virginia 22180  
Order Toll Free 800-368-3270  
Virginia 703-938-3350



# MAILBAG LETTERS TO THE EDITOR

The most interesting questions we receive will be answered here in each issue. Address your questions to: Tom Kneitel, Editor, Popular Communications magazine, 76 North Broadway, Hicksville, NY 11801.

## A Year Ahead Of The CIA

Today, 25 June 1984, I opened my copy of the *Washington Post* and read the fascinating story of "Operation Annie," the American Army's "black propaganda" broadcasting station which undermined Hitler's forces in 1945. The *Washington Post* noted that the story of this amazing broadcaster was obtained from "newly released CIA documents." Being a long time POP'COMM reader, of course I knew the full story of "Operation Annie" since it ran in the April 1983 issue ("The Strange Case of Operation Annie," by Tom Kneitel), well over a year before the CIA declassified their secret files on the operation. Thanks, POP'COMM, for keeping your readers supplied with stories like that one. Keep up the good work.

Larry Palumbo  
Tallahassee, FL

POP'COMM prides itself on having the ability to offer readers insights into the behind-the-scenes stories which might otherwise be filed away and (almost) forgotten. Many of the other stories we have run on wartime operations are still sitting in unreleased files somewhere in Washington. Try this month's "Lusitania" story on for size, Larry. — Editor

## Missing Persons

I wanted to write to several POP'COMM authors to comment upon things in material they have recently written. I was able to look up Dave Beauvais (KB1F) in my ham callbook, but wasn't able to do so with authors Harry Caul and Alice Brannigan since they don't have ham callsigns. Please advise on how they may be contacted.

Al Johnson  
Washington, DC

Harry Caul and Alice Brannigan are both pen names. You can write to these authors in care of the POP'COMM offices and we will forward the letters to them. In fact, mail may be addressed to all authors and columnists in care of our offices and we will forward it to the addressees. — Editor

## More Is Less?

I'm confused! In shopping for scanners I'm confronted by a strange assortment of specs which are apparently intended to help me decide which scanner performs best. I suppose that to many people these specs tell a complete story, but to me they only make matters worse since I can't seem to figure out

their meaning. Some make sense but others are a puzzle, like the sensitivity specs. How important are these, and if presented with sensitivity ratings on different scanners such as 1.0  $\mu\text{V}$ , 0.5  $\mu\text{V}$ , and .12  $\mu\text{V}$ , how do I figure out which one is the most sensitive? My gut feeling is that the most sensitive scanner is the one with the highest (1.0  $\mu\text{V}$ ) rating, but I'm just guessing.

Carlos Hernandez  
Galveston, TX

Your quandry isn't that rare; specs can be confusing to the uninitiated. In the case of scanner (or communications receiver) specs, the set with the lowest  $\mu\text{V}$  (microvolt) rating would offer the better sensitivity — and of the three you mentioned, that would be the set with .12  $\mu\text{V}$  ratings. The public seems to have been programmed to assume that the most is the best, bigger is better than smaller, that a 427 car engine has more moxie than a 350, a 50 kW broadcaster has a better signal than a 10 kW station, etc. In this case, it's the opposite. Here is an instance where you're looking to find a receiver which is best able to detect weak signals. The scanner with the 1.0  $\mu\text{V}$  rating will detect only those signals which arrive stronger than 1.0  $\mu\text{V}$  at its antenna connector; however the scanner with the 0.5  $\mu\text{V}$  sensitivity can detect signals which are far weaker. The scanner with the 1.2  $\mu\text{V}$  rating, however, can pick up signals which are just a hair better than one-tenth of 1 microvolt, so it would be the most sensitive of the three units you mentioned. The importance of sensitivity specs becomes critical the higher in frequency you tune, and even a scanner which displays manufacturer's specs which compare favorably with those of other scanners can be helped considerably by the addition of an RF preamplifier. Also note that sensitivity ratings are often indicated in respect to their relationship to specific signal-to-noise (S/N) ratios. This might be written "S/N 12 dB," but since you didn't mention this, I am assuming that each of the three scanners you checked was rated with the sensitivity specs showing the identical S/N figures. — Editor

## Star Struck

Recently I was in Japan on business and happened to see something interesting in a magazine published there. It was an ad for a piece of electronics equipment and it featured none other than you, Tom, complete with photo and testimonial. It was a snazzy ad. How come I've never seen it here in the States? Were you ever in the movies?

A.T. Rowe  
Oakland, CA

My arrangements with the manufacturer of the equipment were for the ad to appear only in certain specific countries, excluding the United States and Canada. Yes, I was in the movies only last Saturday night, seeing Conan, The Destroyer. — Editor



## Whoops!

I have an authentic Hawaii Five-O badge in my collection and I'm an avid fan of the TV reruns of the program which was made about the Hawaii Five-O. It would be great to listen to the actual Hawaii Five-O unit "in action" when I visit Hawaii with my scanner this coming December. What is their frequency?

Ray Doerr  
Arlington, TX

Don't quite know how to break the news to you Ray, but Hawaii Five-O has never existed as anything other than a well-made TV program. There never has been an actual police unit with that designation. The badges which circulate supposedly from Hawaii Five-O are souvenirs made up for the show's many fans and seem to be selling around for about \$25 each, along with patches, tie tacks, baseball caps, and other similar material. The company which produces all of this authentic looking trivia has never announced a souvenir scanner frequency. Sorry 'bout that. — Editor

## Hard To Hear

Recently, on TV, they showed some American military operations in Central America and mentioned "instant" communications with the Pentagon. Please advise frequencies in use.

William Sandoval  
New York City, NY

Possibly the equipment used is an AN/URC-101 or similar. This is a VHF/UHF manpack operating in the 116 to 150 and 225 to 400 MHz in 25 kHz steps. This transceiver has AM/FM modes available and puts out up to 20 watts (200 watts with a linear amplifier). For maintaining communications with the Pentagon (or White House Situation Room, or CIA headquarters at Langley, VA), FM mode is used as is UHF, beamed to a Dept. of Defense satellite. Although the satellite downlinks are in the 240 to 270 MHz band, they are transmitted in "secure" (scrambled) mode. This is only one of many satellite communications systems in use by military forces. — Editor



# Clean up the computer clutter.

For less than \$250  
you can make your  
investment in yourself  
pay off!

Chances are you have spent a couple thousand dollars on setting up a computer system that gets a lot of your work done. But sometimes it gets to be work to work at it.

I know that when I have to move two program manuals and a pencil holder to boot up the disk drive, it is work. When there is an unlabeled floppy (that I am going to identify some day) on top of the monitor and the business check-book is on top of the printer . . . and I will remember (I hope) before the next "report" comes through . . . that is work.

I found the annoyance of my own "computer clutter" was even worse than the extra work the disorder created. And that is when I started looking for some practical furniture for my computer set up. Since I had already spent a lot of money on the system itself, I was really dismayed when I found out how much it would cost to get a decent-looking desk or even a data table for my equipment. \$400 . . . \$500 . . . even more for a sleazy unit that looked like junk! In fact, it was junk! And it took a long time for me to find something that was really worth the money . . . and more.

A lot of my working day is spent with my computer, and I will bet a lot of your time is too. So I figure a "home" for my system—a housing that is good looking as well as efficient to work at—will pay off two ways:

1. Less work: an efficient and orderly layout will save me time and energy.
2. Personal satisfaction: good quality furnishings look better; they just plain feel better to work at too.

So imagine how good I felt to find the "Micro-Office" Work Center! These are fine pieces of computer system furniture that make my office-at-home as pleasant a place to work as it ought to be. And the



## MICRO-OFFICE WORK CENTER

biggest and best surprise is the low, low price for such good quality.

Here is what you get—all for only \$249.50 plus shipping.

- Mar-resistant work surface. Your choice of oak or walnut grained. Work surface height is adjustable to your keyboard, your chair, your height.
- Two shelves plus work surface extender. Both shelves tilt to lock in position so that monitor faces you—in a position that does away with screen glare squinting and neck craning forever. Retainer bar keeps equipment from sliding off shelf. Snap-in bookends hold reference manuals and programs.
- Strong, sturdy and steady. All-steel welded frame construction is concealed by top-quality wood grain surfaces with finished trim. Adjustable floor levelers included. The work center is really a piece of fine furniture.
- There is no risk in buying from us either. We will make a full refund of purchase

price plus shipping charges if you return the workcenter within 30 days for any reason whatsoever. In addition, the product is warranted for any defects in materials or construction for a full year from date of purchase. This is a no-risk investment in your own productivity and work efficiency that will pay off for years to come—even if you do not yet have a microcomputer of your own.

- Take your choice for your own work center decor:

Order 48-inch unit in walnut, #2KPO-945, or in oak, #2KPO-947. Only \$249.50 for each unit plus \$20.00 shipping charge. On orders for two or more units at the same time, shipping charge applies to only the first unit ordered. Shipment made UPS, so we cannot ship to post office box. Illinois residents please add \$15 per unit sales tax. Please allow 10 extra days for personal checks to clear. Sorry—at these special offer prices we cannot ship c.o.d. or bill direct.

CALL TOLL FREE TODAY WHILE SUPPLIES LAST: 1-800/323-8064.

In Illinois call 1-312/251-5699. Or mail check with order to:

### Micro-Mart Distributors

Dept. PC10 • 1131 Central Street • Wilmette, IL 60091



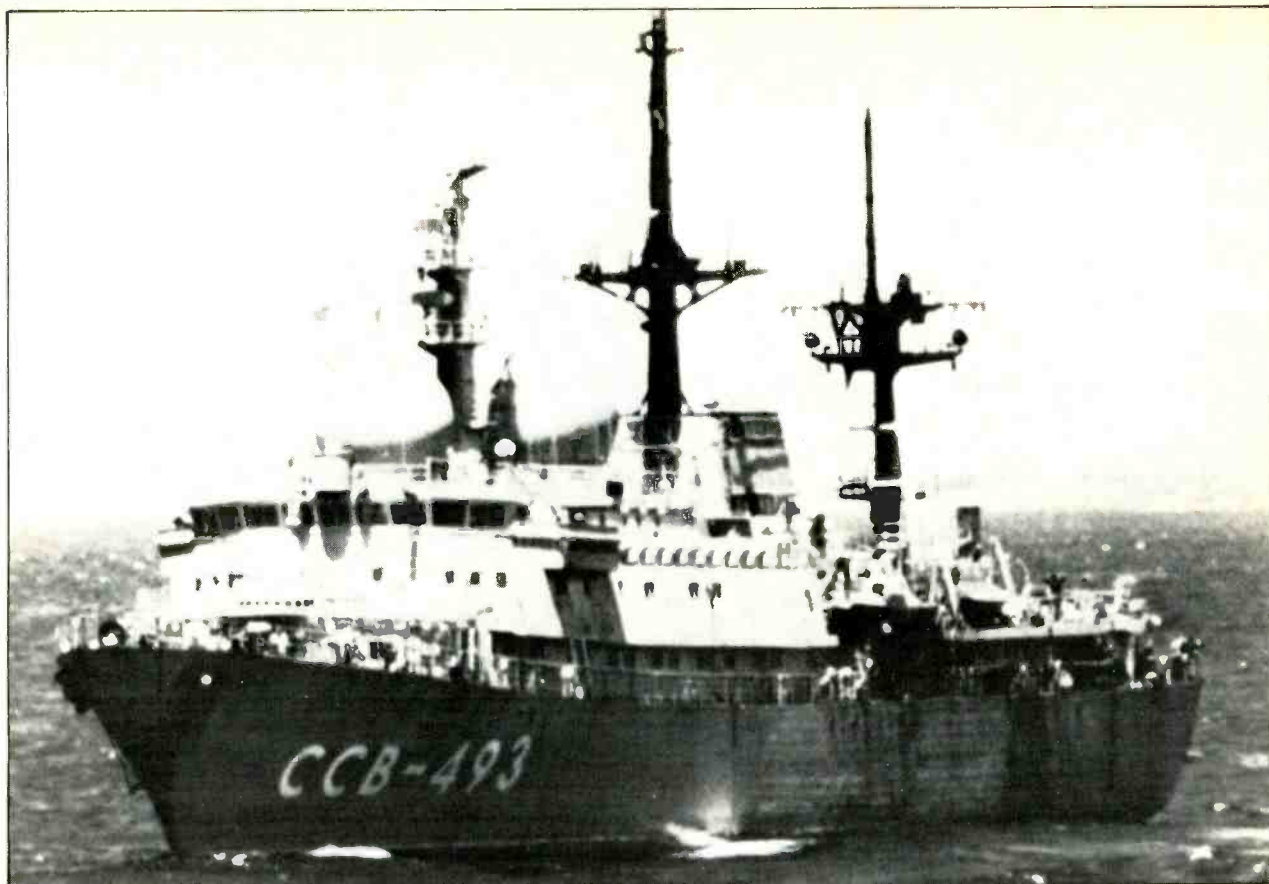

Photo courtesy Department of Defense.

## *How To Monitor*

# Soviet Mystery Ships

***Spy Ships, The Soviet Navy, Fishing Trawlers, & The Rest – The Bottom Line Is That There May Not Be Much Difference Between Them! Here's How To Eavesdrop On Them.***

BY HARRY CAUL, KIL9XL

**S**oviet ships have always been something of a mystery to most folks. Their oddly rigged "fishing trawlers" seem to be less equipped for fishing for cod than for hooking communications; other vessels seen shadowing Western naval forces' vessels are blatant espionage efforts; then, there are all sorts of Russian merchant marine ships—freighters, whalers, tankers, even research vessels—whose scope of operations is suspected of incorporating elements of intelligence gathering.

What many people in the West have difficulty in comprehending is that, while in the West there are naval forces and there are private merchant marine vessels (separate and apart from one another), in the USSR it's different. In the USSR, the government

owns and operates all vessels. Its huge merchant marine, being a governmental operation, is actually subordinated at all times to naval control. Certain roll-on/roll-off vessels can be utilized as military transports. The huge booms which are standard equipment aboard freighters are just as suited to lifting small landing craft as they are to lifting bales of cotton and industrial or farming equipment. This is all within the Soviets' mobilization view of warfare. In the West, vessels in the merchant marine are not included in military planning or spending. In the USSR, the opposite is the case, and in 1981 the Soviets included merchant marine vessels in a major amphibious exercise.

Merchant marine vessels have been accused, suspected, and even observed trans-

porting espionage agents, military equipment, and strategic technology items. Some vessels have space devoted to electronic surveillance equipment and personnel, thus offering limitless opportunities for monitoring from many vantage points around the world, including harbors, ports, and coastlines of all nations trading with the USSR.

The Soviets' intelligence agency, the KGB, operates a large private armada of border patrol craft which are intended to keep unwanted potential trespassers out of the USSR's sea borders (or keep unauthorized vessels from leaving) during peacetime. The KGB employs specially designed vessels (such as hydrofoils and Zhuk class patrol craft) and a large number of modified naval vessels including frigates, former





In the background is the Soviet whaling ship VLADIVOSTOK and in the foreground are Greenpeace environmentalists whose story ran in the January 1984 issue of POP'COMM. (Photo by Rex Weyler)

Greenpeace crewmembers confront Russian whalers aboard the DALNIY VOSTOK (killer boat tied alongside). (Photo by Kazumi Tanaka)



Soviet warships can be heard on many frequencies. (Photo courtesy of the Department of Defense)

minesweepers, torpedo retrievers, and fast patrol vessels. The Soviets also have river gunboats on rivers such as the Amur, Danube, and Ussuri.

All this is to say nothing of the Soviet Navy itself, which (according to various estimates) is either the first or second most awesome in the world. A large array of submarines, aircraft carriers, frigates, cruisers, destroyers, corvettes, and amphibious warfare vessels are in service. The basic operational strategy of the Soviet Navy causes these vessels to be quite active on the airwaves.

The Soviets are not as interested in sea control as they are in sea denial. Their primary approach is the massed attack upon a specific seaborne target such as a submarine, an aircraft carrier, or amphibious

group. Tactics such as these call for complex surveillance systems to detect and track the target while the attack is planned, then to communicate to the attackers the exact location of their target. Since the Soviet submarines are a vital part of such battle plans, they must remain in radio range of surface ships in order to receive their target information. In other words, they are usually near the surface (despite their formidable underwater speed and depth capabilities), a factor which causes them to be photographed often and (sometimes) even get bumped by surface vessels (as happened a few months ago when a U.S. Navy aircraft carrier collided with a Soviet sub located just beneath the surface).

Vessels belonging to the Soviet merchant marine have radio callsigns which are gener-

ally 4-letter types, commencing with the letter "U," or some other prefix letters assigned to the USSR. Typical examples would include: ESXC (cargo vessel Magnit), UQIR (freighter Labinsk), and ERUQ (freighter Gueograf). These callsigns are shown in international merchant marine communications registries because it is necessary for these vessels to have easily recognized identifications in order to conduct commercial shipping operations on the high seas and also for safety purposes. Certainly for the passage of communications relating to espionage or military matters, special unpublished callsigns would be used to thwart identification.

The radio callsigns of fleet vessels of the Soviet Navy, on the other hand, are not shown in international registries. Such callsigns are considered secret by the Russians. Indeed, it was not until about ten years ago that the Soviets placed nameplates on many larger vessels (such as cruiser or destroyer size). Even today, the actual names of most Soviet submarines are unknown (that is, on an unclassified level) in the West. For rapid identification purposes, NATO has arbitrarily assigned its own code names to a number of Soviet ships, ship classes, and even electronics and weapons systems. Some of those NATO code names may well sound Russian in flavor, however they were concocted in the West and do not relate in any way to the actual Soviet names which may have been assigned. Even the popularly encountered class names for Soviet submarines (Romeo, Quebec, Whiskey Long Bin, India, etc.) are purely arbitrary appellations produced by the Western powers for identification purposes.

The Soviet backwards electronics industry has not produced communications equipment which is on a par with that used by the NATO nations, nevertheless, a lack of sophistication doesn't seem to have caused any special lack of ability for the Russian vessels and shore stations to be heard on the shortwave bands.

Shore stations operated by the Soviet government dot the map of the USSR and are also located in Cuba and Angola. Some



**Table 1**

<b>kHz</b>	<b>Mode</b>	<b>Callsign(s)</b>	<b>kHz</b>	<b>Mode</b>	<b>Callsign(s)</b>	<b>kHz</b>	<b>Mode</b>	<b>Callsign(s)</b>
3160	CW	UCY2	8620	CW	UBN	13710	SSB	UXN
3210	CW	UBN	8635	CW	UJQ	13990	CW	COY851
3540	CW	URD	8688	CW	URD	14405	CW	RIW
4223	CW	UGH2	8695	CW	UHK	14468	CW	RIW
4227	CW	UJO5	8725	SSB	URB2	14505	CW	RIW
4230	CW	UFB	8728	SSB	UCY2 UKX	14510	CW	RIW
4233	SSB	UKX	8731	SSB	UPB UFL	14541	CW	RIW
4245	CW	UFN	8738	SSB	UON URD	14555	CW	RIW
4260	CW	UDK2	8759	SSB	UDH UGH2	14697	CW	COY895
4264	CW	RCV	8762	SSB	UFN	14792	CW	CMU967 RIW
4295	CW	UHK	8775	SSB	UMV	15384	CW	CMU967
4271	CW	UBE2	8784	SSB	UJQ	15465	CW	RCV
4283	CW	UQK	8787	SSB	UXN	15497	CW	CMU967
4285	CW	UAH	8790	SSB	UMV	16090	CW	D3M93
4323	CW	UFH	8793	SSB	UBE2	16397	CW	RIW
4345	CW	UFM3	8809	SSB	UFM3	16847	CW	RLO
4349	CW	UXN	9145	CW	RIW	16868	CW	UXN
4357	SSB	UDH UFL	9236	CW	RIW	16891	CW	UFN
		UPB UXN	10434	CW	RIW CMU967	16922	CW	UDK2
4361	SSB	UMV	10510	CW	RIW	16942	CW	RCV
4370	SSB	UCY 2 UFN	10725	CW	CMU967	16960	CW	UMV
		UNM2 UON	10798	CW	RIW	16993	CW	UAT
4392	SSB	UGH2 UJQ	10912	CW	RIW	16997	CW	UDH
4395	SSB	UBN UJO5	11048	CW	RIW	17015	CW	UJQ
		UKX	11114	CW	CMU967 UXR	17063	CW	UFB
4398	SSB	URD	11406	CW	COY895	17077	CW	UAH
4407	SSB	UFM3	11430	CW	UMS	17110	CW	UFL
4413	SSB	UMV	11555	CW	CMU967	17130	CW	ROT
4423	SSB	URB2	12055	CW	RIW	17233	SSB	UFN UNM2
5258	CW	CMU967	12678	CW	UQB	17245	SSB	URD
6335	CW	UFM3	12703	CW	UNM2	17248	SSB	UAT
6369	CW	UQK	12706	CW	UQK	17252	SSB	UFL
6375	CW	UGH2	12723	CW	RCV UAH	17267	SSB	UKX UMV
6387	CW	UJO5	12730	CW	UMV	17276	SSB	UBE2
6394	CW	RIW	12732	CW	UBN	17289	SSB	UBE2
6400	CW	UCY2	12744	CW	RCV	17301	SSB	UJQ
6405	CW	UFN	12752	CW	RIW	17304	SSB	UDH
6410	CW	UDH UHK	12795	CW	UXN	17310	SSB	UQB
6417	CW	UKX	12797	CW	UDK2	17314	SSB	URB2
6420	CW	UJQ	12825	CW	UFH	17317	SSB	UFM3 UGH2
6425	CW	URD	12910	CW	UAT	17323	SSB	UDH
6447	CW	UFB	12955	CW	UFL	17357	SSB	UBN
6455	CW	UDK2 UON	12995	CW	ROT	17504	CW	RIW
6470	CW	UXN	13000	CW	UBE2	19098	CW	RIW
6485	CW	UAH	13040	CW	UFN	21764	CW	RCV RIW
6510	SSB	UDH	13045	CW	ROT	22435	CW	UFL
6513	SSB	UFL UMV	13064	CW	RIW	22450	CW	ROT
7577	CW	RIW	13070	CW	UDH	22497	CW	UDK2
7935	CW	COY895	13101	SSB	UAT UFL	22512	CW	UAT
8436	CW	UCO	13110	SSB	URD	22599	SSB	UFB UFL
8441	CW	UAT	13113	SSB	UDH UFB	22608	SSB	UFM3 UKX
8446	CW	UFM3 UQK			UNM2	22615	SSB	UAT
8456	CW	ROT	13126	SSB	UFN UXN	22627	SSB	UJQ
8508	CW	RIW	13129	SSB	UBE2	22633	SSB	UQB URD
8515	CW	UFL	13157	SSB	UFM3	22680	SSB	UGH2
8523	CW	RIW	13175	SSB	UMV	22689	SSB	UFN
8555	CW	UFH	13181	SSB	UBE2 UGH 2	22692	SSB	UBE2 URB2
8557	CW	UGH2			UKX	22701	SSB	UMV
8570	CW	UPB	13185	SSB	URB2	22711	SSB	UDH
8576	CW	RCV	13188	SSB	UDH	23525	CW	RCV
8610	CW	UXN	13191	SSB	UJQ	25130	CW	ROT

are used only for naval communications, others are used for merchant marine as well as for communications with naval vessels. These stations dot the communications spectrum and may use SSB, CW, or RTTY. A listing of stations using SSB and CW is given in Table 1, shown according to frequency, with the callsigns noted on each frequency indicated.

A cross reference showing the locations for each callsign used is given in Table 2. Also shown (where known) is the stations'

schedule for transmission of "traffic list" broadcasts on those frequencies where CW is in use.

Stations shown using SSB will have the ships in which they are in communication operating "duplex" on frequencies other than the shore station channel. The ship frequencies are lower in frequency than those used by the shore stations. To compute the ship frequencies used for communicating with 4 MHz SSB shore stations, subtract 294.4 kHz from the shore stations' frequen-

cies. For the 8 MHz band, subtract 523.9 kHz; for 13 MHz band, subtract 770.8 kHz; 17 MHz band subtract 772.9 kHz; and 22 MHz band subtract 596 kHz.

For CW operations, vessels communicating with "U" prefixed shore stations will most likely be using frequencies within the same band as the shore station, first establishing contact on a calling frequency and then switching over to a mutually agreed upon working channel. The edges (highest and lowest frequencies) of these communica-

**Table 2  
Shore Stations**

CALL	LOCATION	CW TRAFFIC LISTS AT
CMU967	SANTIAGO, CUBA (NAVY)	
COY851	HAVANA, CUBA (NAVY)	
COY895	HAVANA, CUBA (NAVY)	
D3M93	LUANDA, ANGOLA (NAVY)	
RCV	MOSCOW (NAVY)	
RIW	KHIVA, UZBEK SSR (NAVY)	
RLO	LENINGRAD (NAVY)	
ROT	MOSCOW (NAVY)	
UAH	TALLIN, ESTONIAN SSR	ON THE HOUR
UAT	MOSCOW	ON THE HOUR (EVEN HRS)
UBE2	PETROPAVLOVSK, KAZAKH SSR	ON THE HOUR
UBN	DONETSK, UKRANIAN SSR	ON THE HOUR
UCO	YALTA	
UCY2	ASTRAKAHN	
UDH	RIGA, LATVIAN SSR	ON THE HOUR
UDK2	MURMANSK	
UFB	ODESSA, UKRANIAN SSR	ON THE HOUR
UFH	PETROPAVLOVSK, KAZAKH SSR	
UFL	VLADIVOSTOK	10 MIN PAST THE HOUR
UFM3	NEVEL	
UFN	NOVOROSSISK	ON THE HOUR
UGH2	YUZHNO-SAKHALINSKLY	
UHK	BATUM, GEORGIAN SSR	ON THE HOUR (EVEN HRS)
UJO5	IZMAIL, UKRANIAN SSR	0800 1000 1200 1530 2000
UJQ	KIEV	
UKX	NAKHODKA	
UMS	MOSCOW (NAVY)	
UMV	MURMANSK	ON THE HOUR
UNM2	MEMEL, LITHUANIAN SSR	ON THE HOUR
UON	BAKU, AZERBAIDZHAN SSR	1 MIN PAST THE HOUR
UPB	PROVIDENIYA	
UQB	KHOLM	5 MIN PAST THE HOUR
UQK	RIGA, LATVIAN SSR	
URB2	MEMEL, LITHUANIAN SSR	
URD	LENINGRAD	ON THE HOUR (EVEN HRS)
UXN	ARKHANGELSK	ON THE HOUR
UXR	?	

tions within each band is shown in Table 3. Although callsigns are sent in standard international Morse format, be aware that the actual message texts will contain Cyrillic characters which are not included in Western alphabets. Unless you can understand Russian text, none of this will make much difference to you in any event. You'll be able to copy the callsigns however, and that should provide you with a considerable amount of interesting fare.

It has been observed by a number of monitors that the Soviet so-called "fishing trawlers," which seem to switch hit as spy ships when the occasion calls for it, have been heard communicating with one another (via SSB) on 3347 and 3382 kHz. Other voice frequencies which have produced Russian language two-way communications (assumed to be from spy, merchant marine, and/or naval vessels) include 4392, 4592, and 19050 kHz. Russian text CW communications, thought to be between ships, have been noted on 6765, 10141, 10795, and 14495 kHz.

Check out these frequencies and tune in on the mysterious Soviet fleet which seems obsessed with stalking NATO naval vessels, monitoring naval maneuvers, space shots, and activities ashore throughout the world!



*Monitoring enthusiasts have copied signals from Soviet warships, though it isn't easy to figure out what they're saying. (Photo courtesy of the Department of Defense)*

**Table 3  
SHIP CW BANDS (KHZ)**

4171-4177	WORKING
4180-4187.2	CALLING
6256.5-6263.5	WORKING
6270-6280.8	CALLING
8344-8351	WORKING
8360-8374.4	CALLING
12493-12498.5	WORKING
12540-12561.6	CALLING
16660.6-16663.5	WORKING
16720-16748.8	CALLING
22194.5-22195.5	WORKING
22227-22247	CALLING

**New From EEB**

**Digital vs Analog  
Battle Is Over**

The Winner Fluke  
New Fluke 70 Series combining digital & analog displays at low cost



Fluke 73	Fluke 75	Fluke 77
<b>\$85</b>	<b>\$99</b>	<b>\$129</b>
Analog/digital display Volts, ohms, 10A, diode test	Analog/digital display Volts, ohms, 10A, mA, diode test	Analog/digital display Volts, ohms, 10A, mA, diode test
Autorange 0.7% basic dc accuracy 2000+ hour battery life 3-year warranty	Audible continuity Autorange/range hold 0.5% basic dc accuracy 2000+ hour battery life 3-year warranty	Audible continuity "Touch Hold" function Autorange/range hold 0.3% basic dc accuracy 2000+ hour battery life 3-year warranty Multipurpose holster

**FLUKE** Dealer Inquiries Invited

**ESKA RX99PL NEW**

**Professional Receiver  
PLL-Synthesized AM/SSB  
99 Memories - AM PL DET.**

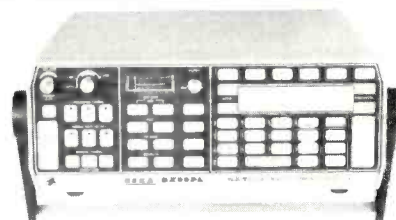

Hi tech from Europe never before available a receiver with so much  
Price range \$800-\$1500  
Delivery Dec. 1984  
Free SWL Catalog  
Dealer inquiries invited

**BIRD Electronics**  
East Coast's #1 Distributor  
Complete Line Available

Call for quotes on all your Bird needs Dealer inquiries invited

**800-368-3270**

**Electronic Equipment Bank**  
(703) 938-3350  
516 Mill Street N.E.  
Vienna, VA 22180





A map of Beirut, the capital of Lebanon.

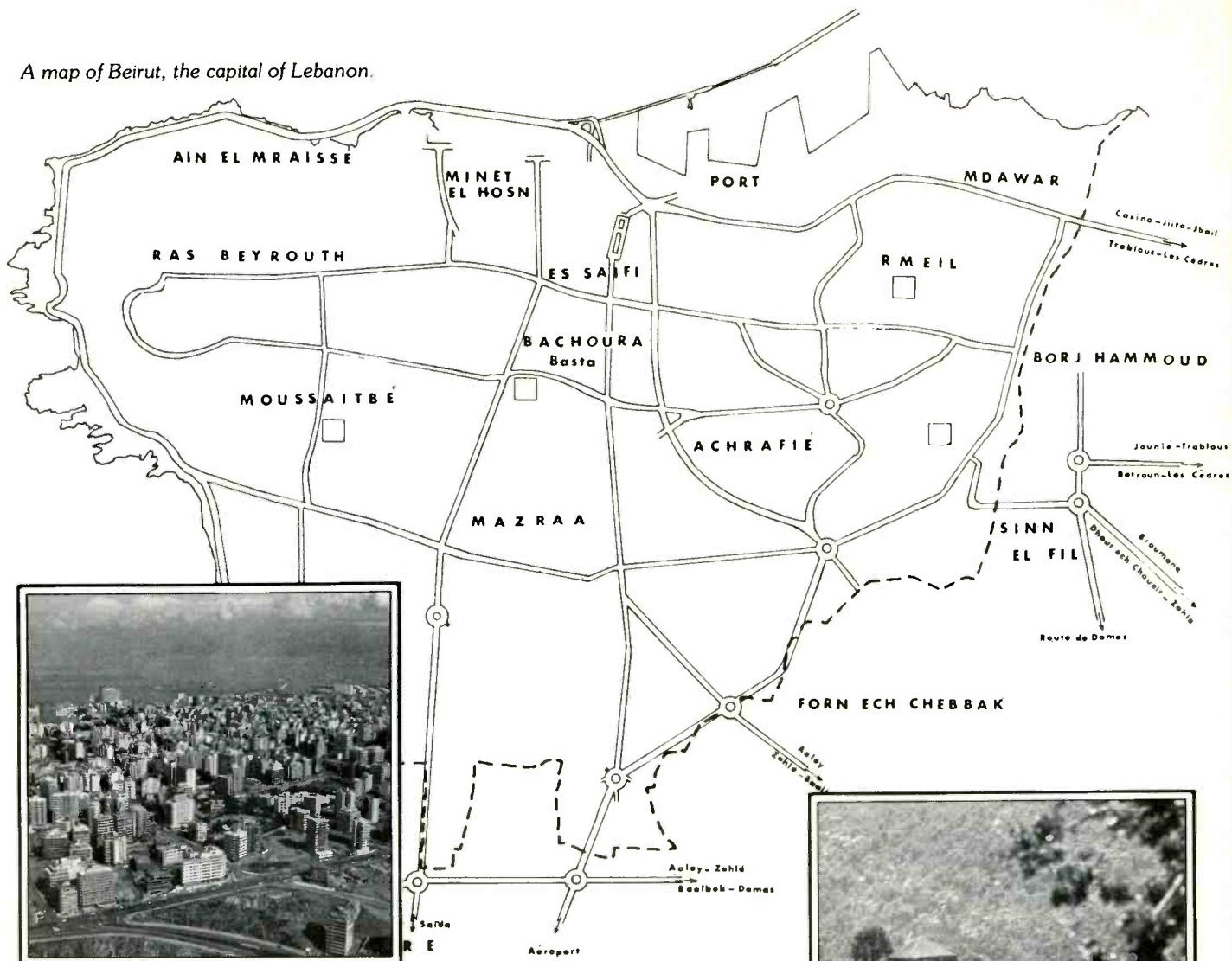

Beirut—the jewel as it once was.

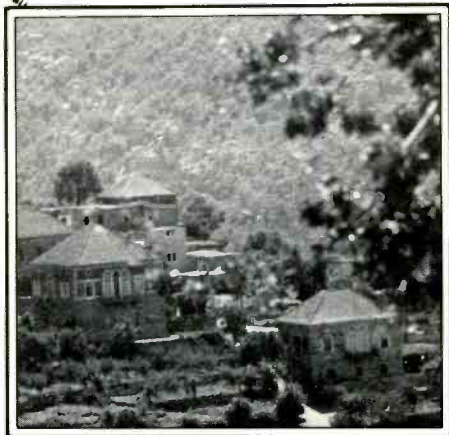

Lebanon's mountains and valleys have isolated sects through hundreds of years and allowed them to develop their own ways and beliefs.

# Torn Fabric: Radio In Lebanon

**Tune In As All "Sides" Clamor  
For Your Listening Attention**

BY GERRY L. DEXTER

It has been said that divine justice stumbled once and the result was Lebanon. It is a collection of both natural and man-made treasures boasting of a heavenly prejudice. Unfortunately, the tourist literature is tearfully out of date.

Lebanon has been a major item in our daily news menu for a few years now. We have all soaked up at least some awareness of the broken puzzle that is Lebanon. Beirut, once a shimmering jewel on the coast, lies battered, torn by battle waged both internally and by outside forces. Once it was the play-

ground of the Middle East, a financial capital, a center of fashion, learning, and trade. But that is not so today, not after all these months of suffering at the hands of sons and neighbors.

Lebanon was once a part of the Ottoman Empire, but even under that regime it was never tightly controlled, and local princes in Lebanon had a considerable amount of leeway in their own actions and decisions. Perhaps that is where the pattern began.

Britain and France (mostly the latter) got involved in Lebanon in 1918 as the Ot-

toman Empire collapsed. The League of Nations created Lebanon in 1923 with the French army staying on to provide security. The French also expanded Lebanon to its present size, a move which proved both a blessing and a curse. Although beneficial from an economic standpoint, the move also incorporated a large Muslim population which had no previous loyalty to the idea of Lebanon.

It's hard to say when Lebanon really came into being—1941 when independence was proclaimed, 1943 when the first elections



George Otis and Major Haddad dedicate the Voice of Hope radio station in Free Lebanon.

for a provisional government were held, or 1944 when French resistance to the new leadership gave out and an actual government was established.

Some three million people live in Lebanon, sharing their borders with Syria and Israel—two of the main protagonists now involved in the country. Syria feels that Lebanon is virtually a part of its land and wants a greater say in Lebanese affairs. Israel wants a peace treaty to put up on the mantelpiece alongside the one it has with Egypt.

The Lebanese themselves are descended from the Phoenicians, the Hebrews, Armenians, Arabs, and a mixed-bag of others.

Lebanon contains a bewildering array of groups, sects, political viewpoints, and outlooks. There are some 40 private armies, each loyal to a particular chief or politician. There are Maronite, Orthodox, Catholic (Byzantine), and Armenian Orthodox Christians. There are Sunni and Shiite Muslims. There are the Druze and the Jews. There is the PLO. And those are just the main groupings. One can refine the political and religious affiliations down to a much narrower base.

Each group has its own way of looking at things. The main difficulty in recent years has been the too weighty Christian representation in the government and the belief by other segments that they should have a greater say in running the country. Add to that invasion by outside elements, terrorism, assassination, and mayhem. Every day provides a new excuse for somebody to get even with somebody else.

Much of the problem is also the result of Lebanon's beautiful scenery. The many mountains and valleys have helped nurture the various sects and have kept them isolated over the years, creating numerous regional-political-religious mindsets that are not easily changed.

The broadcasting scene in Lebanon reflects the confused and conflicting politi-

cal/religious scene. Many of the main groups operate their own radio stations. For the most part, this trend has been developing since 1976. At that time, another civil war took place and various factions decided they should be able to put their own political views on the air since the only other radio service in the country was run by the government. Many of the stations have remained on the air since.

The government claims its "love of democracy" has caused it to allow these private stations to remain on the air, this despite the fact that Lebanese law restricts broadcasting to the government alone. The question arises, of course, whether the government could close the other stations if it wanted to do so, since Beirut's authority is very limited.

The government's Radio Lebanon has been around for many years. Two 100-kilowatt foreign service transmitters operate from Amchit, about 35 kilometers north of Beirut. Usually, the government radio's international service broadcasts in Spanish, French, Arabic, and English. In April, 1984 Christian Phalangists occupied the transmitter site at Amchit and cut the link to the Radio Lebanon studios in Beirut, leaving only a low-powered transmitter in the city for Radio Lebanon to use. This transmitter was medium wave and severely restricted the station's coverage. The Phalangists controlling the area around Amchit hoped to set up a new station and were said to be using the transmitters there. One other private broadcaster simply referred to them as "gunmen."

It's not known at present whether Radio Lebanon has regained access to its shortwave transmitters. The most recent available schedule had them broadcasting in English to Europe and the Mideast from 0400 to 1000 GMT and 1615 to 1845 on 5.980; from 1000 to 1615 on 9.545; from 0130 to 0330 to North America on 9.660; 1830 to 2030 to West Africa on 11.830 or 11.890; and 2300 to 0100 to South America on

11.855 or 11.955. Recently an agreement was signed with the French to provide technical and administrative aid to Radio Lebanon. They probably need it. Should you log the station, reception reports can be sent to the Ministry of Information, Beirut. Medium wave frequencies of 835 and 989 kiloHertz as well as an FM channel are also in use.

The Voice of Arab Lebanon is operated by Al-Murabitan, the independent Nassarite Movement. It uses 930 kiloHertz medium wave and a shortwave frequency which started out on 6.204, moved to 6.223, and is now somewhere around 6.400 MHz. Broadcasting runs from 0400 to 2050 in Arabic with some newscasts in French as well. The station began operations sporadically in 1975 and has operated fairly regularly since the summer of 1978. Power on shortwave is 15 kilowatts. At one time the station often used the "River Kwai March" as an identifying tune, though we can't say for certain if that theme is still in use today. It has been heard by many listeners in the United States, although logging the station requires careful tuning and good reception conditions. It is difficult to get reception reports through to the station, but a few replies have been received from Rue Barbour, Cornich El-Mazraa, Beirut.

Wallid Jumblat's Progressive Socialist Party (the Druze) operates the Voice of the Mountain from a location in the Shuf Mountains overlooking Beirut. This one is on 1080 kiloHertz, medium wave only, with a power of 25 kilowatts and plans to double its output. It has been reported that the station wishes to add a shortwave facility as well—welcome news for DXers if it happens.

The station calls itself the "voice of all nationalities opposing fascist and phalangist control over the country." Programming covers the activity of all the political elements in the country.

The station's personnel were trained in the United States and the equipment is also American-made. Some attempts have been made to bomb the station in the past and the Progressive Socialist Party now provides daily security for the station's installation. Broadcasting began in February, 1984. The PSP says that they would have put the station on the air much earlier but delayed in the hope that the government was going to close down the other private stations. If you can't lick 'em, join 'em.

High Adventure Ministries of California operates the King of Hope-Voice of Hope from Christian "Free Lebanon" in the south. The station was born after the late Major Sa'ad Haddad requested a meeting with High Adventure President George Otis who was visiting Israel. Haddad wanted Otis to try and get him a low power transmitter so he could speak to his people regularly. Matters mushroomed at that point and the result, six months later, was the WORD of Hope on 945 kiloHertz with the KING of Hope fol-



*Studios of the Voice of Hope/King of Hope located near Israel in the "Valley of the Kings."*

lowing later on a shortwave frequency of 6.215 (with 6.665 expected to replace that frequency in the future). An FM stereo channel also went into operation.

The station was built with the support of High Adventure Ministry members, primarily in the United States. Security is provided by Christian forces as well as Israeli military personnel. The station is located in the Valley of the Kings, near Marj'uyun, within sight of Metulla, Israel. Studios, initially at least, were in an old French customs building.

When the station first came on the air, a PLO newspaper said the station should have been called "The Voice of Doom" since it would be "blown to oblivion within two days." It didn't happen. Since the fall of 1979 when WORD went on the air, broadcasting has continued on an almost uninterrupted basis. Some damage to the station was done in 1983 when a booby-trapped car exploded but there were no injuries. The station has been hit by bullets a few times but, again, personnel have come through unscathed. One part-time Lebanese volunteer was killed by a land mine, but his death was not connected with his radio work.

High Adventure got into television as well, placing the Star of Hope color television station on the air. It has since been sold to the Christian Broadcasting Network.

The station currently broadcasts in nine languages, including English. Surprisingly, country western music makes up a large part of the program fare. There are reasons for that rather odd choice—no one else was doing it and surveys showed that it might go over very well. Besides, High Adventure didn't feel they could go on the air with a heavy diet of religious music given their location and target audience. Apparently the format has been extremely well received. The schedule runs from 0400 to 2310. If you hear the station, reception reports can be sent c/o the Arizim Hotel, Metulla, Israel or to High Adventure Ministries, P.O. Box 7466, Van Nuys, California 91409.

The frequency of 1412 kiloHertz must be an interesting one to monitor if you live in Beirut. The Voice of the Palestinian Revolution conducted experimental transmissions from the Nahr al-Baird Camp in late 1983 and announced itself as the radio of the Palestine Liberation Organization. This was, in fact, an anti-Arafat effort and no longer operates here. The Voice of Palestine/Voice of the Palestine Revolution/Voice of National Unity have used the frequency before. Both pro and anti-Arafat forces seemingly had control of the facility as the war between the two PLO factions moved back and forth through the area in late 1983.

Since the spring of 1984 a station using this triple name has been on 1504 from an unknown location, operating from 1700 to 1900. This anti-Arafat group seems to be anti-just-about-everything — Anti-Egypt,

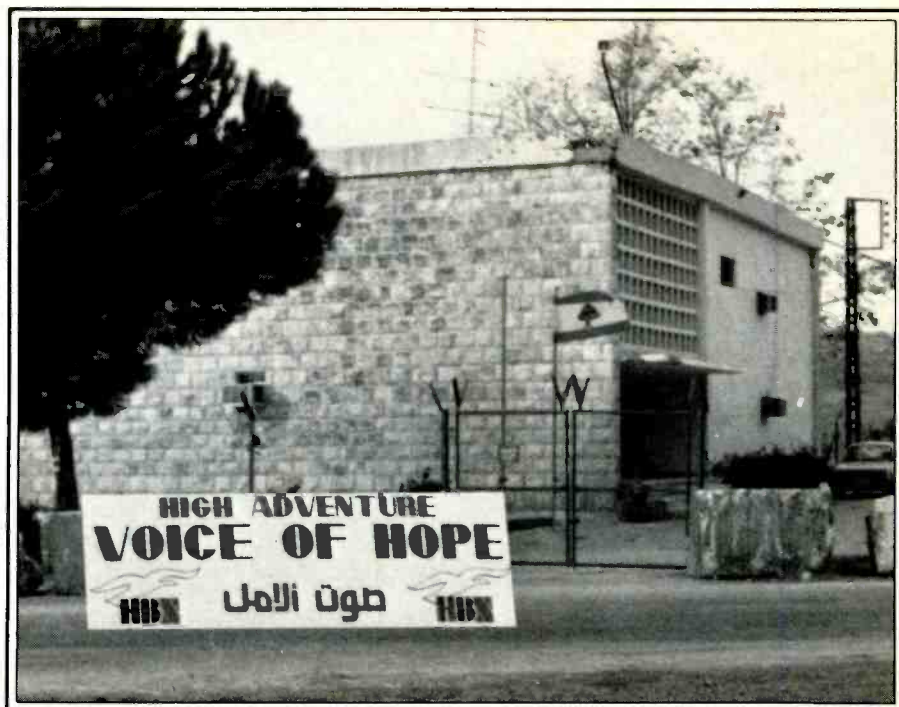

anti-Jordan, anti-Iraq, anti-Saudi Arabia. What it does support is Palestinians and Syrians working together in a "Nationalist Lebanon Movement."

The pro-Phalangist Voice of Lebanon (Voice of Freedom and Dignity) started broadcasting in the fall of 1975 but only on an off-again, on-again basis until 1977. It's on 873 kiloHertz medium wave and 6.550 shortwave as well as FM. It even runs commercials. Programming is from 0415 to 2125 mostly in Arabic but with news in French at 0700, 1000, and 1500 and news in English at 0800, 1200, and 1600. It has been heard a number of times in the United States. Reception reports go to P.O. Box 165271, a-Ashrafiyah, Beirut.

The views of former Lebanese Prime Minister Sulayman Franjiyah are touted by the Radio of Free and Unified Lebanon which is on medium wave only at 585 kiloHertz. The station is operated by something called the "Central Command" in Zgharta and also identifies itself as the "Voice of the North." It has been on the air since the summer of 1978 and broadcasts in Arabic only from 0600 to 1800.

Radio Free Lebanon supports former President Sham'un and calls itself the "radio of Lebanon's steadfastness and resistance" and is supposedly operated by the "Lebanese Forces," the military wing of the Christian Phalangists. It calls for Syria to pull its forces out of Lebanon. The station is on 1476 kiloHertz in Arabic from 0400 to 2300 with English and French newscasts as well.

Islamic extremists operate something called the Voice of Justice as the mouthpiece of the Islamic Unification Movement. No frequency for this station is known but it apparently operates from a location near Tripoli, Lebanon.

There are still other stations which don't seem to be on the air yet. One is to be operat-

ed by the Islamic Shiite Amal Movement and expects to actually have two stations—one political and one religious. Or, they may make one of the outlets a commercial venture in order to provide funds to operate the other. Chances are these will be on medium wave only.

Radio Objective, operated by the al-Moqasid Charity Association, is also said to be in the planning stages and hopes to put out a signal that will reach as far as Cyprus.

Of the several stations operating in Lebanon today, only a portion of them are on shortwave; Radio Lebanon, the government outlet—assuming they get their transmitters back and clicking (we almost said "ticking" but that seems a poor choice!); KING of Hope; The Voice of Lebanon, and the Voice of Arab Lebanon. We may see more show up on the higher frequencies.

Reception of the Lebanese shortwave outlets, often even of the government station, is by no means easy. Listeners in the Eastern half of the United States will have considerably better luck in tuning them in. Under the right conditions they can be heard well into the midwest or even deeper into the continent. But, tough or not, they are worth trying for; you will be listening to a piece of history.

As this is written, the various elements that make up the kaleidoscope of Lebanese religions and politics are trying yet again to put all of the pieces of the puzzle back together, or at least get them all back into the box. Whether they are successful or whether "all the kings horses and all the kings men can't put Humpty Dumpty back together again" is a question the world waits to have answered. Lebanon has seen much turmoil in its day. It has risen from ashes more than once and regained its place as the showpiece of the Middle East. Perhaps, one day, it will do so again. **PC**

# NEW!

## Regency<sup>®</sup> Scanners

Communications Electronics,<sup>™</sup> the world's largest distributor of radio scanners, introduces new models with special savings on all radio scanners. Chances are the police, fire and weather emergencies you'll read about in tomorrow's paper are coming through on a scanner today.

We give you excellent service because CE distributes more scanners worldwide than anyone else. Our warehouse facilities are equipped to process thousands of scanner orders every week. We also export scanners to over 300 countries and military installations. Almost all items are in stock for quick shipment, so if you're a person who prefers fact to fantasy and who needs to know what's really happening around you, order your radio today from CE.

### NEW! Regency<sup>®</sup> MX5000-E

List price \$599.95/CE price \$359.00  
**6-Band, 20 Channel • No-crystal scanner**  
**Search • Lockout • Priority • AC/DC**  
**Selectable AM-FM modes • LCD display**  
**World's first continuous coverage scanner**  
Frequency range: 25-550 MHz. continuous coverage. Never before have so many features come in such a small package. The Regency MX5000 mobile or home scanner has continuous coverage from 25 to 550 MHz. That means you can hear CB, Television audio, FM broadcast stations, all aircraft bands including military and the normal scanner bands, all on your choice of 20 programmable channels.

### Regency<sup>®</sup> MX3000-E

List price \$319.95/CE price \$179.00  
**6-Band, 30 Channel • No-crystal scanner**  
**Search • Lockout • Priority • AC/DC**  
Bands: 30-50, 144-174, 440-512 MHz.  
The Regency Touch MX3000 provides the ease of computer controlled, touch-entry programming in a compact-sized scanner for use at home or on the road. Enter your favorite public service frequencies by simply touching the numbered pressure pads. You'll even hear a "beep" tone that lets you know you've made contact.

In addition to scanning the programmed channels, the MX3000 has the ability to search through as much as an entire band for an active frequency. The MX3000 includes channel 1 priority, dual scan speeds, scan or search delay and a brightness switch for day or night operation.

### Regency<sup>®</sup> Z30-E

List price \$279.95/CE price \$169.00  
**6-Band, 30 Channel • No-crystal scanner**  
Bands: 30-50, 144-174, 440-512 MHz.  
Cover your choice of over 15,000 frequencies on 30 channels at the touch of your finger.

### Regency<sup>®</sup> C403-E

List price \$99.95/CE price \$59.00  
**5-Band, 4 Channel • Crystal scanner**  
**Channel indicator LED • AC only • Low cost**  
Bands: 30-50, 148-174, 450-470 MHz.  
Regency's basic scanner, the C403 gives you the excitement of police, fire and emergency calls at a budget price. It can tune in to any of five public service bands and brings the signal in loud and clear...on any of four possible channels. It comes with detachable telescope antenna and AC power cord. Order one crystal certificate for each channel you want to receive.

### Regency<sup>®</sup> HX1000-E

List price \$329.95/CE price \$209.00  
**6-Band, 30 Channel • No Crystal scanner**  
**Search • Lockout • Priority • Scan delay**  
**Sidelit liquid crystal display • Digital Clock**  
Frequency range: 30-50, 144-174, 440-512 MHz.  
The new handheld Regency HX1000 scanner is fully keyboard programmable for the ultimate in versatility. You can scan up to 30 channels at the same time. When you activate the priority control, you automatically override all other calls to listen to your favorite frequency. The LCD display is even sidelit for night use. A die-cast aluminum chassis makes this the most rugged and durable hand-held scanner available. There is even a backup lithium battery to maintain memory for two years. Includes wall charger, carrying case, belt clip, flexible antenna and nicad battery. Order your Regency HX1000 now.

### Regency<sup>®</sup> R106-E

List price \$159.95/CE price \$92.00  
**5-Band, 10 Channel • Crystal scanner • AC/DC**  
Frequency range: 30-50, 146-174, 450-512 MHz.  
A versatile scanner, the Regency R-106 is built to provide maximum reception at home or on the road. Rugged cabinet protects the advanced design circuitry allowing you years of dependable listening.

### NEW! Regency<sup>®</sup> R1050-E

List price \$179.95/CE price \$109.00  
**6-Band, 10 Channel • Crystalless • AC only**  
Frequency range: 30-50, 144-174, 440-512 MHz.  
Now you can enjoy computerized scanner versatility at a price that's less than some crystal units. The Regency R1050 lets you in on all the action of police, fire, weather, and emergency calls. You'll even hear mobile telephones.

Programming the R1050 is easy. Merely touch the keyboard and enter any of over 15,000 frequencies on your choice of 10 channels.

### Regency<sup>®</sup> HX650-E

List price \$129.95/CE price \$79.00  
**5-Band, 6 Channel • Handheld crystal scanner**  
Bands: 30-50, 146-174, 450-512 MHz.  
Now you can tune in any emergency around town, from wherever you are, the second it happens. Advanced circuitry gives you the world's smallest scanner. Our low CE price includes battery charger/A.C. adapter.

### NEW! Regency<sup>®</sup> HX-650P-E

List price \$189.95/CE price \$104.00  
Now, Communications Electronics offers a special packaged price on the Regency HX-650 scanner and the following items for only \$104.00. You get the Regency HX-650 scanner, a set of 4 AAA ni-cad batteries, the MA-506 carrying case, six crystal certificates, AC adapter/charger and flexible rubber antenna for only \$104.00 per package plus \$10.00 shipping/handling. To order this special package, use CE special order number HX-650P-E.

### QUANTITY DISCOUNTS AVAILABLE

Order two scanners at the same time and deduct 1%, for three scanners deduct 2%, four scanners deduct 3%, five scanners deduct 4% and six or more scanners purchased at the same time earns you a 5% discount off our super low single unit price.

### NEW! Regency<sup>®</sup> MX7000-E

List price \$699.95/CE price \$449.00  
**10-Band, 20 Channel • Crystalless • AC/DC**  
Frequency range: 25-550 MHz. continuous coverage and 800 MHz. to 1.2 GHz. continuous coverage  
In addition to normal scanner listening, the MX7000 offers CB, VHF, and UHF TV audio, FM Broadcast, all aircraft bands (civil and military), 800 MHz communications, cellular telephone, and when connected to a printer or CRT, satellite weather pictures.

The Regency Touch MX7000 provides the ease of computer controlled, touch-entry programming in a compact-sized scanner for use at home or on the road. Enter your favorite frequencies by simply touching the numbered pressure pads. You'll even hear a "beep" tone that lets you know you've made contact.

In addition to scanning the programmed channels, the MX7000 has the ability to search through as much as an entire band for an active frequency. When a call is received, the frequency will appear on the digital display.

### Regency<sup>®</sup> Z10-E

List price \$239.95/CE price \$138.00  
**6-Band, 10 Channel • No-crystal scanner**  
**Priority control • Search/Scan • AC/DC**  
Bands: 30-50, 140-174, 440-512 MHz.  
Cover your choice of over 15,000 frequencies on 10 channels at the touch of your finger.

### OTHER RADIO ACCESSORIES

B-4-E 1.2 V AAA Ni-Cad batteries (set of four) ..... \$9.00  
A-135C-E Crystal certificate ..... \$3.00  
A60-E Magnet mount mobile antenna ..... \$35.00  
A70-E Base station antenna ..... \$35.00  
Add \$3.00 shipping for all accessories ordered at the same time.  
Add \$3.00 shipping per scanner antenna.

### BUY WITH CONFIDENCE

To get the fastest delivery from CE of any scanner, send or phone your order directly to our Scanner Distribution Center.<sup>™</sup> Be sure to calculate your price using the CE prices in this ad. Michigan residents please add 4% sales tax or supply your tax I.D. number. Written purchase orders are accepted from approved government agencies and most well rated firms at a 10% surcharge for net 10 billing. All sales are subject to availability, acceptance and verification. All sales on accessories are final. Prices, terms and specifications are subject to change without notice. All prices are in U.S. dollars. Out of stock items will be placed on backorder automatically unless CE is instructed differently. A \$5.00 additional handling fee will be charged for all orders with a merchandise total under \$50.00. Shipments are F.O.B. Ann Arbor, Michigan. No COD's. Most products that we sell have a manufacturer's warranty. Free copies of warranties on these products are available prior to purchase by writing to CE. International orders are invited with a \$20.00 surcharge for special handling in addition to shipping charges. Non-certified checks require bank clearance.

Mail orders to: Communications Electronics,<sup>™</sup> Box 1002, Ann Arbor, Michigan 48106 U.S.A. Add \$7.00 per scanner for U.P.S. ground shipping and handling in the continental U.S.A. For Canada, Puerto Rico, Hawaii, Alaska, or APO/FPO delivery, shipping charges are three times continental U.S. rates. If you have a Visa or Master Card, you may call and place a credit card order. Order toll-free in the U.S. Dial 800-521-4414. In Canada, order toll-free by calling 800-221-3475. WUI Telex CE anytime, dial 671-0155. If you are outside the U.S. or in Michigan dial 313-973-8888. Order today.

Scanner Distribution Center<sup>™</sup> and CE logos are trademarks of Communications Electronics Inc.

†Regency is a federally registered trademark of Regency Electronics Inc. AD #080384-E

Copyright © 1984 Communications Electronics

## Order Toll Free... call 1-800-521-4414

# COMMUNICATIONS ELECTRONICS<sup>™</sup>

### Consumer Products Division

818 Phoenix □ Box 1002 □ Ann Arbor, Michigan 48106 U.S.A.  
Call TOLL-FREE 800-521-4414 or outside U.S.A. 313-973-8888

CIRCLE 37 ON READER SERVICE CARD

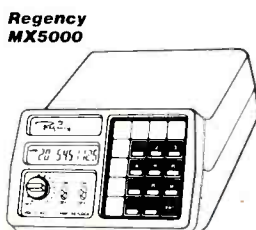
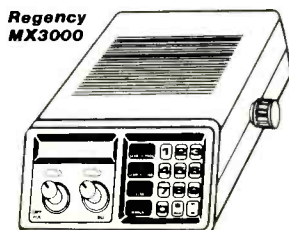



# Germany's High Power Spy Station — In The USA!

## *Did Our Government Look The Other Way While It Operated?*

BY TOM KNEITEL, K2AES, EDITOR

**C**herry Avenue. It sounds so downright American, like Cherry pie or a reference relating to the tree little Georgie Washington was supposed to have chopped down. Not so, for Cherry Avenue in the small Long Island community of Sayville was the location for what must certainly have been one of the most unusual and notorious espionage stations ever put on the air. It was there that mysterious radio messages were sent out in a manner so clever that it shook the foundations of the neutrality of the United States.

Our story starts in early 1913. In those days there was no broadcasting. Radio was the realm of the home experimenter (or ham) and the shipboard "brasspounder" or telegrapher, with a handful of coastal stations in operation to communicate with the ships at sea and to send telegrams to overseas points. The majority of commercial wireless telegraph stations in the United States were operated by foreign corporations such as Marconi, Pathe, and the large German company known as Telefunken.

Telefunken had erected a wireless telegraph station at Sayville, New York, centered around an operations building and an imposing 500-foot transmitting tower. The Sayville station received its first test messages from Telefunken's station POZ in Nauen, Germany, on May 10, 1913. The first transmitter tests from Sayville to POZ took place on July 15, 1913, with the station opening for full commercial operation on January 27, 1914, complete with goodwill greetings exchanged between President Woodrow Wilson and the German Kaiser. But Sayville was not Telefunken's only interest in American wireless.

At about the same time the Sayville station was being placed in service, there was a German electrical engineer setting up a station of his own in Tuckerton, New Jersey. The engineer, Dr. Goldschmidt, called his station "WGG." It was complete with a gigantic transmitting tower more than 850 feet into the sky. Goldschmidt's plan was also to exchange commercial messages with Telefunken's station POZ in Nauen. His

business arrangements were simple; he formed a company called the Goldschmidt Wireless Telegraph Company. Telefunken's equipment was used throughout WGG and it was generally felt that Goldschmidt had exchanged stock in his company for this equipment (Goldschmidt never admitted to this). Fact was that Telefunken had become the actual owners of the Goldschmidt facility. WGG began testing with POZ on July 5, 1913, and by June 18, 1914, it was opened for full commercial traffic. The usual messages of goodwill were exchanged between President Wilson and the Kaiser.

Interestingly, about the only piece of equipment installed at Sayville and Tuckerton that was not made by Telefunken was a strange looking device produced in the United States. This was a piece of equipment called the Telegraphone made by the American Telegraphone Co. of Springfield, Massachusetts. The Telegraphone had the ability to record messages on steel wire by means of electromagnetism.

Telefunken then decided to help publicize their new Sayville station and thereupon erected a large electric billboard reading "Telefunken High Power Radio Station Sayville NY." This billboard was placed at the Sayville operations building, a structure that was easily visible to the many passengers on the Long Island Railroad since that line's tracks ran alongside the Cherry Avenue property owned by Telefunken.

Perhaps this was too high a profile for Telefunken to assume, times being what they were. It wasn't long before the billboard came to the attention of Senator Henry Cabot Lodge. Lodge quickly became uncomfortable about this German-owned station located in the United States. He took note that both Sayville and Tuckerton went into full service just as war broke out in Europe. Indeed, Goldschmidt's station opened for business a mere ten days prior to the assassination of Austrian Archduke Ferdinand—an act which was the pretext for the war. The United States was a neutral nation and Lodge wondered if such stations

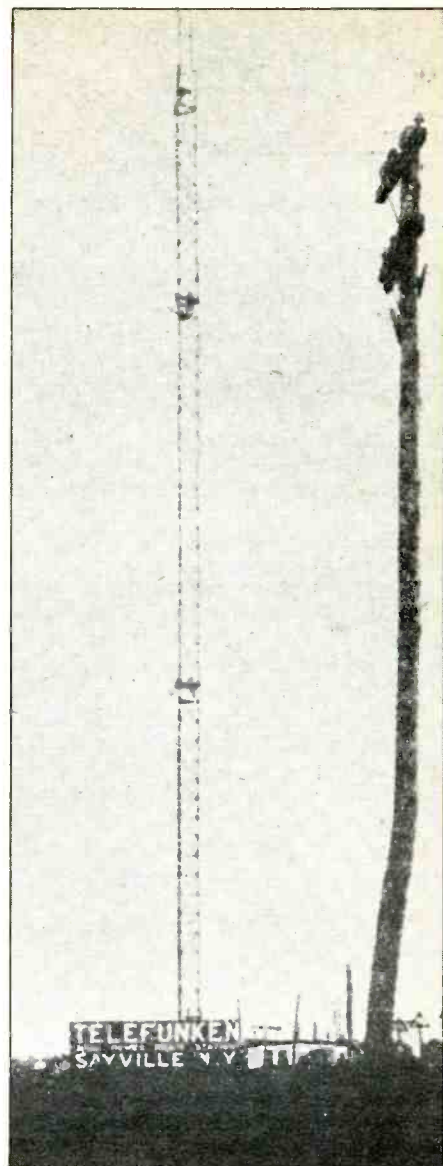

*The station at Sayville as it looked in 1915 before the Navy took it over. The large electric billboard can be seen at the base of the tower.*

might eventually be used for espionage purposes or against our interests, or that such stations could jeopardize our neutrality. Lodge then caused laws to be enacted which would bear upon international wireless operations. They stated that all stations must have licenses that are issued to either American citizens or American owned corporations. Under the law, the Bureau of Navigation was allowed to regularly inspect all licensed stations and, should a national emergency arise, the President was empowered to take over any licensed station. Moreover, messages had to be transmitted in "plain English" without the use of codes or ciphers.

### **Sayville, Another Story**

Sayville remained on the air, and the large Telefunken sign was still in place. A newspaper reporter contacted Telefunken to find out how the station managed to re-

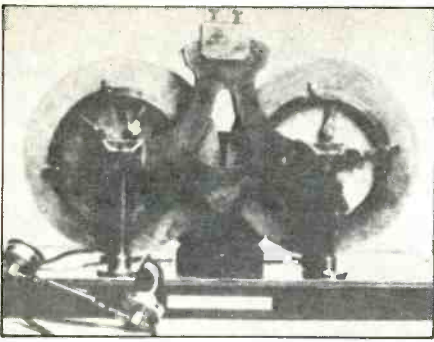

Early prototype model of Poulson's Telegraph which used steel wire to make magnetic recordings. The WWII German Magnetophon was obviously a descendant of this device, which was also the inspiration for all modern tape recording machines.

main in operation. Telefunken casually responded that they had recently sold all of their interests in the station "to Americans."

Indeed, further checking revealed that Telefunken did not hold the license for Sayville! The license had been issued to the Atlantic Communication Company, 90 West Street, New York, NY. Mr. A. E. Debec, Atlantic's General Manager, claimed that American stockholders owned Atlantic "with some German capital." The President of Atlantic was none other than Congressman Herman Metz, just completing his first term in Congress after a long and successful career in industry. He had made a sizeable fortune manufacturing and importing (from Germany) pharmaceuticals and textile dyes. Metz had firm business contacts in Germany and at one time had been the American representative of important German firms, including Agfa and I. G. Farben.

It is at this point that it is worth taking a look at the piece of American made equipment mentioned earlier that had been installed at both Sayville and Tuckerton—the Telegraphone.

This device had been devised by the Danish inventor Vlademar Poulson and was intended originally to increase the capacity of landline telephone circuits. Two spools of wire (like piano wire) were used in what was essentially a magnetic recorder not unlike a modern tape recorder. Poulson's idea was to record messages at normal speed and then send them out at high speed, thus permitting perhaps eight times the number of messages to be sent within the same time frame as messages sent at normal speed. At the receiving end, a similar Telegraphone was employed to record the high speed messages and then replay them at a slower (normal) speed so that they could be understood. Poulson realized the message security aspects of his invention, but primarily he saw the advantages as being shortened message time and also the ability to repeat messages by replaying them as often as desired.

In 1904 Poulson gave a franchise to the American Telegraphone Company to produce and sell a working commercial model of his device. American Telegraphone viewed the invention not so much as an aid

The German 4-stack passenger liner Kronprinz Wilhelm was turned into a dangerous raider and radio relay ship. After nine months at sea on a cruise which covered 20,000 miles, on April 10, 1915, the tired ship limped into the U.S. past British warships outside of Chesapeake Bay. The American government seized the ship when we entered the war in 1917 and used it as a troop transport. When the war ended, the old ship was too worn out to place it back into passenger service. It sat at a dock, rotting and rusting, until 1923 when it was scrapped.

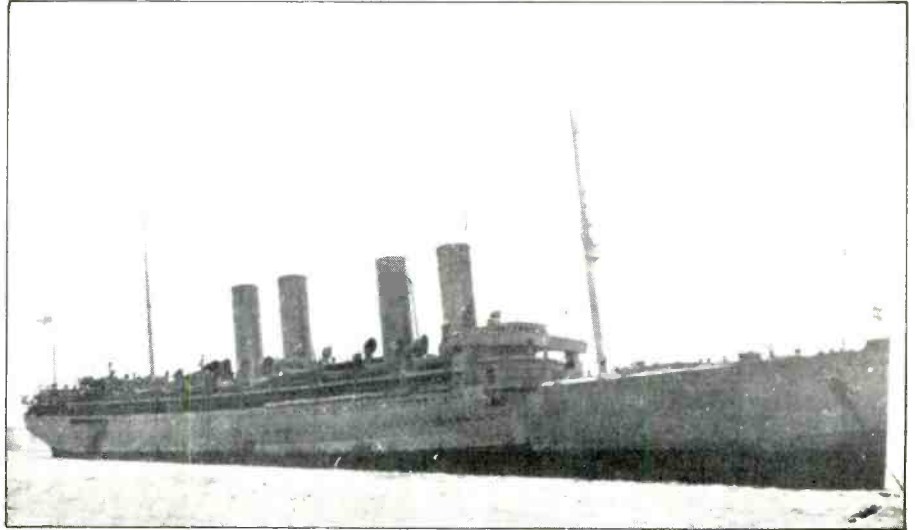

to the landline but rather as a standard business machine which could compete with (at half the price) the Edison Dictaphone (which used wax cylinders instead of steel wire). After four years (and \$100,000) of development, the company had not produced a machine that could be marketed. Enter industrialist Charles D. Wood with an overflowing checkbook. His infusion of \$188,000 in new capital was sufficient to perk up the faltering company and get it going again. This act also gave him control over the company, a fact which did not sit especially well with other stockholders. Some time later, an attorney representing the miffed shareholders would suggest that the \$188,000 may have come from the same powerful forces that were backing the Atlantic Communication Company.

Nevertheless, American Telegraphone did develop a finished machine and produced a few of them for some select customers, most notably The Goldschmidt Telegraph Co., Telefunken, and the Imperial German Navy. The company's sales representatives, enthused by the fact that several units had been produced, were literally screaming for a product to sell to waiting customers. Wood held them off, saying that the current model was still "imperfect" and that a new revised model was on the drawing boards. The U.S. Army was told the same thing in 1917 when it attempted to purchase several units for dictation purposes.

Interestingly (according to a letter written by Dr. Lee de Forest in the February, 1931, issue of *Radio-Craft* magazine), de Forest had a Telegraphone while he was at the Palo Alto laboratory of the Federal Telegraph Company in the summer of 1912. He said that he recorded press telegraph messages regularly from San Francisco, and in March of 1913 it was installed for commercial work

between San Francisco and Los Angeles—attaining code speeds of 90 wpm.

In fact, in 1931, de Forest revealed that in the fall of 1912, the Federal Telegraph Company had sold a complete Telegraphone installation to the U.S. Navy for use at their main radio station (NAA) in Arlington, Virginia.

One of the Telegraphones, despite its supposed imperfections and without any cooperation from its manufacturer, appeared at the 1915 Panama-Pacific Exposition in San Francisco and quickly won a Gold Medal.

## Meanwhile, Back At World War I

The first week of August, 1914, was quite eventful. For one thing, a German passenger liner (and former holder of the Blue Riband trophy for speed in crossing the Atlantic) left New York harbor in considerable haste. She was loaded with 2,000 tons more coal than necessary for her to reach Europe. She carried all of the supplies and provisions she could hold. As soon as she left New York, instead of steaming towards Europe, the SS *Kronprinz Wilhelm* headed to the West Indies and rendezvoused with the German cruiser *Karlsruhe*, where she took aboard two 81 mm. guns, ammunition, and several large crates marked "electrical apparatus." The owners of the *Kronprinz Wilhelm*, North German Lloyd Lines, did not seem alarmed that the ship did not turn up in Europe as expected, probably because of the other events of the week.

Those other events included the outbreak of war as German forces invaded France. England decided that she would support France by cutting the transatlantic cable that connected the United States to northern



# CUNARD



## EUROPE VIA LIVERPOOL LUSITANIA

Fastest and Largest Steamer  
now in Atlantic Service Sails  
SATURDAY, MAY 1, 10 A.M.  
Transylvania . . . Fri., May 7, 5 P.M.  
Orduna . . . Tues., May 18, 10 A.M.  
Tuscania . . . Fri., May 21, 5 P.M.  
LUSITANIA, Sat., May 29, 10 A.M.  
Transylvania . . . Fri., June 4, 5 P.M.

Cibraltar - Genoa - Naples - Piræus  
S.S. Carpathia, Thur., May 13, NOON

ROUND THE WORLD TOURS  
Through bookings to all principal Ports  
of the World.  
COMPANY OFFICE 21 BENTLEY ST. N.Y.

### NOTICE!

TRAVELLERS intending to embark on the Atlantic voyage are reminded that a state of war exists between Germany and her allies and Great Britain, and her allies; that the zone of war includes the waters adjacent to the British Isles; that, in accordance with formal notice given by the Imperial German Government, vessels flying the flag of Great Britain, or of any of her allies, are liable to destruction in those waters and that travellers sailing in the war zone on ships of Great Britain or her allies do so at their own risk.

IMPERIAL GERMAN EMBASSY.  
WASHINGTON, D. C., APRIL 21, 1915

The German government placed ads in New York newspapers, right next to the Lusitania's sailing schedule, warning of the dangers passengers might expect.

Europe. That left the only direct communications between the United States and Europe the wireless. Henry Cabot Lodge's fears were closer to coming true than he had hoped. On August 7, the Navy Department installed two observers at WGG in Tuckerton to watch what was going on there and perform any necessary censorship. By the end of August the new licensing law caught up with WGG since Goldschmidt was a German citizen and a foreign corporation

The RMS Lusitania was sunk with great loss of life in 1915 while it was secretly transporting military supplies from the United States to Britain. It appears that coded "mystery" signals from the wireless station in Sayville, New York were used to alert the Germans of its secret cargo.

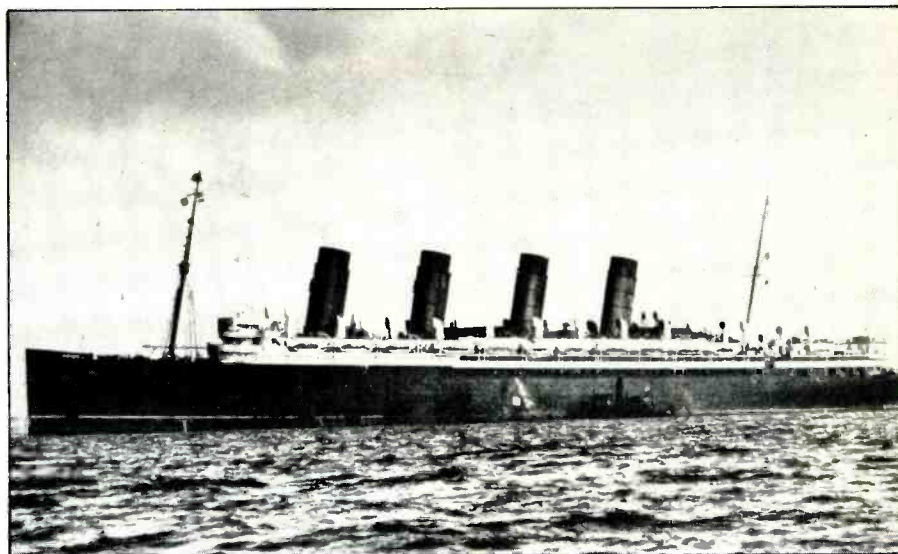

owned much of the company's stock. Navy Secretary Josephus Daniels ordered the station seized and shut down without delay. By mid-September, the Tuckerton station returned to the air, but this time as a unit of the U.S. Navy, staffed by naval personnel, and with a new U.S. Navy callsign, NWW. The station operated on 9200 kHz.

Even though Sayville's license seemed to be free of legal jeopardy, the station said it was having difficulty maintaining reliable communications with Europe. What to do? After some thought they announced that what they really needed was an ocean-based relay station to pick up their signals and pass them along to POZ in Nauen. As luck would have it, it seemed that there was a German ship, the *Kronprinz Wilhelm*, sailing around in the Atlantic that was fully equipped with the very latest in electrical apparatus which could tackle the job. *Kronprinz Wilhelm* was no longer a passenger liner, it was a floating radio relay station. More importantly, it had become a stalking bloodhound—a dangerous Imperial German Navy raider prowling the seas, eventually sinking more than 60,000 tons of shipping in the form of 26 Allied freighters. The bizarre tie-in of the (apparently) American-owned telegraph station in Sayville and this grisly raider gave the news media inspiration to dig a bit deeper into the corporate structure of the Atlantic Communications Corporation.

Upon further investigation it was realized that Atlantic's secretary-treasurer, Dr. Karl George Frank, was a German national who was the actual honcho of the company. Rep. Herman Metz, the corporation's American president, was no more than a figurehead who held barely enough company stock to permit him to qualify as a corporate officer. All other stock was held by Telefunken, its subsidiaries, affiliates, officers, or cronies. Moreover, the man in charge of the Sayville

transmitting station was an officer in the Imperial German Navy, a Capt. Zenneck.

Sayville's transmissions, it should be noted, were causing some confusion with ham operators and others who liked to tune the shortwaves. After the station made contact with POZ in Nauen, several routine messages were exchanged, but then the signal became a strange chatter. This was the sound made by the Telegraphone.

### The Lusitania

On May 7, 1915, the world was jolted by the news of the sinking of the British passenger liner *RMS Lusitania* of the Cunard Lines. The liner carried a full passenger list, including Americans. The *Lusitania* had been (two years earlier) armed with twelve deck guns and was registered as an armed auxiliary cruiser. The day prior to its fateful voyage, the *Lusitania* was loaded with cargo, primarily contraband in the respect that its contents were not listed on the vessel's official cargo manifest documents. While the official cargo manifest consisted of only one sheet, the fact was that the unofficial/secret manifest was 24-pages in length and itemized more than 60 tons of military ordnance and munitions destined to be used by the British against the Germans. The Germans had long warned transatlantic passengers that it was not safe for them to travel on British vessels because of the state of war between England and Germany; ads were even placed to that effect on the shipping pages of New York newspapers.

This voyage in particular seemed to generate a certain tension even before the *Lusitania* had left from Pier 54, and there were advance rumors that it might never make it to its destination in Liverpool. The rumors were justified. As the *Lusitania* steamed towards the coast of Ireland (without any military escort, so as not to arouse suspicions as



# TWO TORPEDOES SINK LUSITANIA; MANY AMERICANS AMONG 1,200 LOST; PRESIDENT, STUNNED, IN SECLUSION.

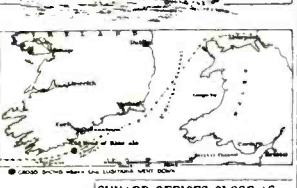
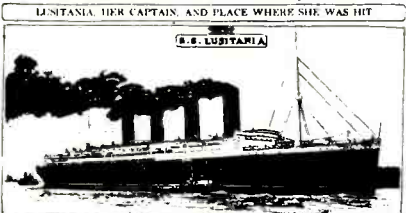

### WASHINGTON, SILENT, AWAITS ADVICES ON AMERICANS' FATE

### CUNARD OFFICES CLOSE AS LIST OF THE DEAD GROWS

When the President's official word comes, the country will be silent. The President is expected to be in seclusion, and the White House is expected to be closed to the public. The President is expected to be in seclusion, and the White House is expected to be closed to the public.

The Cunard office in New York is expected to be closed. The office is expected to be closed, and the office is expected to be closed. The office is expected to be closed, and the office is expected to be closed.

LINER ATTACKED SUPPOSEDLY BY GERMAN SUBMARINE OFF THE IRISH COAST, AND GIVES DOWN IN FIFTEEN MINUTES—LUNCHBOX BEING SERVED AT THE TIME—SURVIVORS PICKED UP FROM LIFEBOATS AND TAKEN TO QUEENSTOWN. FORTY MILES DISTANT—REGARDING 1,254 PASSENGERS AND 850 OF CREW ABOARD. CUNARD LINE SAYS "FIRST OFFICER JAMES HOOK TO 100. AN SAVED" SHIP LEFT NEW YORK LAST SATURDAY WITH MANY AMERICANS, INCLUDING PROMINENT NEW YORKERS, WHO DISREGARDED GERMAN WARNING NOT TO SAIL.

LONDON, May 8.—The Cunard liner Lusitania was torpedoed, supposedly by German submarines, shortly after 11 o'clock yesterday afternoon, on nine miles off the old head of Mizen, on the south coast of Munster, Ireland.

The attack occurred about 150 miles from the Lusitania's principal passengers, among whom were many women, several of the crew and one steward.

Describing the experience of the Lusitania's steward said:

"The passengers were at lunch when a submarine came up and fired two torpedoes, which struck the Lusitania on the starboard side, one forward and the other in the engine-room. They caused terrific explosions.

"Capt. Turner immediately ordered the boat out. The ship began to heel heavily, immediately, but in which was approached the boat with three other boats, and we were packed up shortly after 4 o'clock by the stern.

"I fear that few of the officers were saved. They acted bravely.

"There was only fifteen minutes from the time the ship was struck until the foundering, going down before us. It was a dreadful sight.

"The other survivors with survivors are approaching Queenstown.

"An official statement issued by the Cunard Steamship Company said:

"First Officer James Hook from 100 to 100 were saved. This includes passengers and crew, and is only estimated.

"A dispatch to the Chronicle from Queenstown says that 'seven torpedoes were discharged from the German attacking craft, one of them striking the Lusitania amidships.' This view is supported by the fact that at least two submarines were engaged against the liner. Even the name of the submarine which carried out the attack and most of them have only been identified.

"A dispatch coming from Kinsale at 7 o'clock says that at 3:30 two torpedoes were intercepted as they were fired by the submarine. It is said that the first of the torpedoes was fired from one of the submarines and from the other it, most of them women and children. They were taken to Queenstown in lifeboats, and they were rescued.

"These survivors said the Lusitania got two torpedoes, the first of which struck her on the port side. She carried the second, and received the second on the starboard side.

"They sank a heavy list to port followed, and the Lusitania rolled over for only ten minutes, and only six minutes could be launched. These contained about 800 passengers.

"Other reports say that the first of the torpedoes struck the liner just five minutes, the second striking it in the engine room. Terrific explosions followed, and great volumes of water were poured in through the hull.

"A minority report to the Chronicle says that the number of survivors at Queenstown is 320.

"An identity report said that between 300 and 400 survivors have been landed at Queenstown, including many hospital cases, some of whom have died.

"In this report it is added that some were also landed at Kinsale. The number not having yet been reported. Private telegrams say that 'several hundred passengers' have been landed at Cullinstown, near far from Kinsale.

### Hospitals at Queenstown Caring for Lusitania's Survivors; Dead and Wounded Arriving on Boats From Scene of Disaster

It is reported that the number of survivors at Queenstown is 320. An identity report said that between 300 and 400 survivors have been landed at Queenstown, including many hospital cases, some of whom have died.

### 3 Years' Work—Cost, \$8,000,000—Sunk by Torpedo—Cost, \$4,000,000

The Lusitania was a fast and powerful liner, and was one of the most modern ships in the world. She was built at a cost of \$8,000,000, and was one of the most powerful ships in the world. She was built at a cost of \$8,000,000, and was one of the most powerful ships in the world.

By this time the public was so angry that the Navy finally dispatched three lieutenants to the Sayville station to keep an eye on the operations there. They said they found nothing amiss. Still the strange messages could be heard almost every night. There were rumors that the German operators behaved themselves while the navy personnel were standing over their shoulders watching them, but as soon as they stepped out for a smoke or a coffee break the "funny" signals would start up again. One of the naval officers did agree that this was why the messages were still going on, but the following day he denied it.

A New Jersey experimenter named Charles A. Apgar, later to become famous as "the pioneer home recorder," was trying to figure out the messages. Starting on June 7, 1915, Apgar recorded the nightly messages on his Edison Dictaphone. While he was playing them back the Dictaphone began to malfunction and slow down. It was then that he realized that the whine was turning into Morse code. He copied down the letters and numbers and then looked them up in a German-English dictionary. His discovery sent him rushing to the office of L. R. Krumm, Chief Radio Inspector of the New York office of the Bureau of Navigation. Krumm wasted no time in summoning William J. Flynn of the U.S. Secret Service to show him the messages that Apgar had to offer. They were coded and obviously related to espionage.

By July 1 the Providence Journal's expert had also figured out that he was being asked to monitor ultra high-speed telegraphy and his revelations in the newspaper's pages caused a sensation. The expert noted that the station in Nauen had been demanding repeats of many messages, supposedly because of poor reception. However, when the supposed repeats were sent, they didn't match up with any prior transmissions—they were merely strings of numbers which did not relate to stock exchange or cotton exchange prices. The expert said that they did seem to correlate to military information and to supplies being sent from the United States to England.

Less than a week later, on July 6, the Secretary of the Navy directed Capt. W. H. G. Bullard to seize the Sayville station. Nobody seemed more surprised than the three naval lieutenants stationed there. It did not appear, however, that the Atlantic Communications personnel were taken by surprise. A newspaper reporter who had been keeping the station under surveillance said that the day prior to the navy takeover there were many crates and boxes loaded into trucks at the station, and the trucks drove off into the darkness on the night of July 5. The three naval officers said that they had noticed nothing unusual taking place at the station on July 5 and history did not record whether the Telegraphone was included in the items packed up and shipped out. Bullard quickly shrouded Sayville in deep secrecy, far more than anything known to the Atlantic Communications personnel when they were running things.

The front page of The New York World announcing the sinking of the Lusitania. Although it promoted the "two torpedo" theory to explain the double explosion, passengers reported seeing only one torpedo. Capt. Schwieger, of the German U-20 which sank the ship, insisted that he used only a single torpedo. The second explosion was obviously the 60 tons of munitions in the Lusitania's cargo hold. President Wilson, although "stunned, in seclusion" was fully aware of the vessel's contraband cargo and was possibly aware (in advance) of the exact place and time the Lusitania would be torpedoed.

to its cargo), it was spotted by a German submarine. The U-20 was returning to its base from patrol when it practically stumbled upon the Lusitania by accident—or so the legend went.

But odd rumors were afoot. The Swiss correspondent of the London Morning Post claimed that word had arrived by wireless about the sinking so far in advance that the reporter had his story already written. German newspapers knew in advance when and where the sinking was to take place. In New York, a spokesman for the German government claimed that German U-boats had been given notice by wireless that the Lusitania was carrying war materials for Britain when it left New York on May 1, adding that Germany took the only action it could since it was at war with England, and also because England was not permitting war material shipments sent to Germany to reach their destination.

Nevertheless, the public was outraged at the loss of 1,198 lives (128 American). It certainly did seem apparent that there must have been a message of some sort sent out from Sayville which confirmed the sailing and tipped off Berlin about the secret cargo. Despite German apologies and promises to pay for damages, the public outcry against the sinking was at a fever pitch. The media, in particular, was demanding the immediate closing of the Sayville station, or at least for the station to be operated under strict observation from the government. The American government took no hasty actions and said that it was considering its options in the light of our neutrality and the facts at hand. Still the mystery signals poured forth from the Sayville station—so much so that the Providence Journal (RI) secured the services of a high-speed telegraphy and crypto expert to see if he could figure out the strange transmissions and transcribe the hidden messages.



# "INSIDER'S INFORMATION"

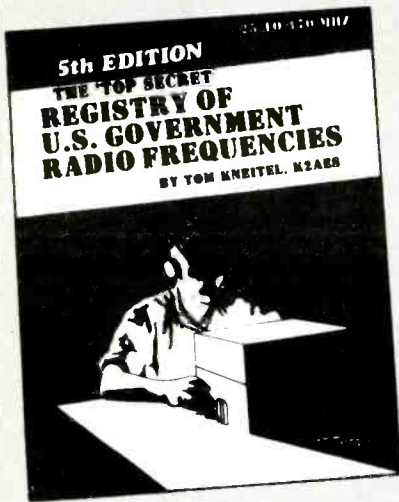

Since 1967, CRB Research has been the world's leading publisher and supplier of unique hobby and professional books and information including:

- Scanner Frequency Guides
- Shortwave Frequency Guides
- Military/Federal Communications
- Broadcast Station Registries
- Undercover Communications
- Survival Communications
- Covert Operations
- Electronic Espionage
- Surveillance
- Monitoring
- Cryptography & Codes
- Bugging
- Wiretapping
- Communications Antennas
- Electronics & Projects
- Authentic Combat Communications Cassettes
- Computer Technology
- & Other Related Topics!

New titles are constantly being added to our exciting catalog. If it's interesting and unusual, we've got it. You'll see! Ask for our latest FREE catalog!

**CRB RESEARCH**

P.O. Box 56 Commack, NY 11725

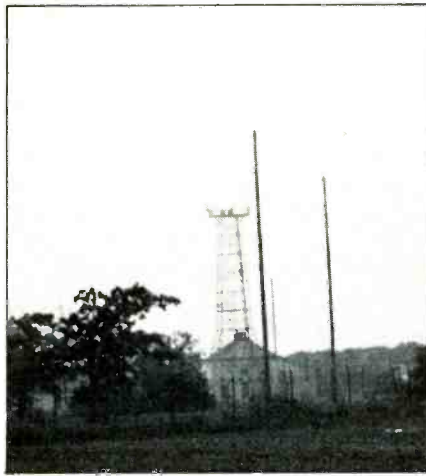

The site of the old Sayville wireless station is presently the location of a major Federal Aviation Administration overseas communications facility. Here's how it looks today.

By the end of July, Bullard announced that the U.S. Navy was to install a 100 kW transmitter in Sayville which would provide better communications with Europe. By September 3, 1915, Sayville returned to the air on 9800 and 11600 kHz using the U.S. Navy callsign NDD. As of that date, NDD, and the Tuckerton station (NWW) were used exclusively for official military communications and all commercial traffic was discontinued.

When the war ended, the Tuckerton station was placed in civilian commercial (RCA) use under the callsigns WSC and (again) WGG. Sayville operated under the control of Mackay Radio Telegraph with the callsigns WML and WSL. In 1934, Mackay gave the Sayville site back to the Navy and moved its operations to Brentwood, New York. Presently, Sayville is the location of an FAA overseas transmitting station. Although it is behind a locked chainlink fence, many of the old structures and tower footings are still on the Sayville transmitter site.

It may have occurred to you that there are some dangling ends to this story. For one thing, you may be asking yourself why our government seemed so apathetic about clamping down on the Sayville operation and only sent some officers there after much hysterical media and public outcry. The officers didn't seem to do much good and it was only after further pressure that the station was finally closed down. Keep in mind that although many people these days seem to recall that the sinking of the *Lusitania* was what brought the United States quickly into the war, in actual fact we did not get into the war until April 6, 1917, almost two years after the *Lusitania* incident. Until February of 1917 we had full diplomatic relations with Germany; we were doing business with Germany until then despite the rather delicate condition of international affairs.

Don't forget that the Navy had probably taken the Telegraphone from the Tuckerton station and (although it was not revealed until 1931) also had a complete Telegraphone

installation at their Arlington radio station. It seems quite likely that Naval Intelligence was fully aware of the nature and content of the Sayville transmissions right from the start but was more interested in using them to furnish us with intelligence than it was in removing them from the air, especially since—being that the United States was neutral and Sayville did have a license to operate, albeit jaded—there was some justification for letting it operate. It appears as though we had good reasons to permit the Germans to continue to send out their secret messages and events show that we were not anxious to jeopardize this source of communications intelligence.

Of course, this raises the question that if the Sayville station sent out relevant advance information about the *Lusitania* sinking, then our government might have had it within its power to prevent or avoid the disaster. Perhaps so, but remember that the *Lusitania* was not an American vessel. Furthermore, there were plenty of rumors circulating that the ship might be attacked, backed up with German warnings and threats in American newspapers. A prudent voyager might have decided against sailing. Also, we may not have wanted to tip off the Germans that we were eavesdropping on (and understanding) their sped-up messages, an act which would have undoubtedly ended our ability to continue the practice. That we did not take action to avoid a military disaster known in advance is a charge which was leveled against our government at other times in our history, most notably the attack on Pearl Harbor in 1941.

It was only after the sinking of the *Lusitania* and highly publicized private investigations into the nature of the Sayville station's messages and ownership that the government could no longer offer logical reasons why it should not be silenced. This could indicate that the information we had been extracting from Sayville was so vitally important to our interests that the *Lusitania* might well have been sacrificed to keep the information flowing. For the station to have had to be silenced as an act of public appeasement almost two years before we entered the war could have been a devastating information loss to our Naval Intelligence Service.

The British denied that there were contraband munitions on the *Lusitania* and produced an innocent looking cargo manifest at the official Admiralty hearings, even though the dual explosions which racked the vessel indicated otherwise (one torpedo supposedly sank the "unsinkable" ship in only 18 minutes). A second (and different) cargo manifest turned up in the United States, while the ship's owners offered yet another different and innocent manifest. It was not until 20 years after the sinking that President Franklin Roosevelt was sorting through some of President Woodrow Wilson's files and turned up a fourth version of the *Lusitania*'s manifest—apparently a carbon copy of the secret manifest which went to the bottom of the ocean with the ship, one which carefully itemized 60 tons of military supplies. **PC**

# NEW LISTENING ADVENTURES



## HEAR MORE THAN EVER BEFORE WITH THE NEW M-600A MULTI-MODE DECODER

Simple connections to your shortwave receiver and video monitor or printer will let you monitor thousands of Morse and Radioteletype signals in Marine, Commercial, Government, Military and Press Services. Converts standard CW and RTTY plus low and high speed ASCII, non-standard shift RTTY, Bit-Inverted RTTY and TOR (Telex Over Radio -FEC & ARQ). Isolated loop MIL-188 or RS232 provided; optional parallel printer port available.

### CONTACT US FOR DETAILED INFORMATION

Phone: 614 866-4267  
MC & VISA Accepted

## UNIVERSAL SHORTWAVE RADIO

1280 Aida Drive, Reynoldsburg, Ohio 43068

Please send all reader inquiries directly.

# QUALITY PARTS AT DISCOUNT PRICES!

## SUB-MINIATURE D TYPE CONNECTOR

SOLDER TYPE SUB-MINIATURE CONNECTORS USED FOR COMPUTER HOOK UPS  
DB-15 PLUG \$2.75  
DB-15 SOCKET \$4.00  
DB-15 HOOD \$1.50  
DB-25 PLUG \$2.75  
DB-25 SOCKET \$3.50  
DB-25 HOOD \$1.25

## "PARALLEL" PRINTER CONNECTOR

SOLDER STYLE 36 PIN MALE USED ON "PARALLEL" DATA CABLES  
\$5.50 EACH

## KEY ASSEMBLY

5 KEY \$1.00 EACH  
CONTAINS 5 SINGLE-POLE NORMALLY OPEN SWITCHES MEASURES 3 1/4" LONG

## 6 KEY

\$1.25 EACH  
CONTAINS 6 SINGLE-POLE NORMALLY OPEN SWITCHES MEASURES 4 1/4" LONG

## CRYSTAL

CASE STYLE HC33/U COLORBURST 3579.545 KC \$1.00 EACH  
2 MHZ \$3.50 EA

## 7 CONDUCTOR RIBBON CABLE

SPECTRA-STRIP RED MARKER STRIP, 28 GA STRANDED WIRE \$5.00 PER ROLL (100 FT.)

## 13 VDC RELAY

CONTACT S.P.N.C. 10 AMP @ 120 VAC ENERGIZE COIL TO OPEN CONTACT COIL, 13 VDC 650 OHMS SPECIAL \$1.00 EACH

FREE! FREE! FREE!

SEND FOR

FALL '84

48 PAGE CATALOG

## MINIATURE TOGGLE SWITCHES

ALL ARE RATED 5 AMPS @ 125 VAC  
S.P.D.T. (on-on) \$1.00 EACH  
P.C. STYLE NON-THREADED BUSHING 75¢ EACH  
10 FOR \$7.00

S.P.D.T. (on-off-on) \$1.00 EACH  
P.C. LUGS, THREADED BUSHING 75¢ EACH  
10 FOR \$7.00

## SOLID STATE BUZZER

STAR #SMB-06L 6 VDC TTL COMPATIBLE \$1.00 EACH  
10 FOR \$9.00

## 120V INDICATOR

NEON INDICATOR RATED 120 V 1/3 W 75¢ EACH  
10 FOR \$7.00  
100 FOR \$65.00

## EDGE CONNECTORS

22/44 22/44 GOLD PLATED CONTACTS 156 CONTACT SPACING \$2.00 EACH  
10 FOR \$18.00

## 5 STATION INTERLOCKING

MADE BY ALPS 3-2PDT AND 2-6PDT SWITCHES ON FULLY INTERLOCKING ASSEMBLY 3/4" BETWEEN MOUNTING CENTERS \$2.50 EACH

## 5 STATION NON-INTERLOCKING

SAME AS ABOVE, EXCEPT EACH SWITCH OPERATES INDEPENDENTLY \$2.50 EACH

# ALL ELECTRONICS CORP.

905 S. VERMONT • P.O. BOX 20406 • LOS ANGELES, CA 90006

TOLL FREE ORDERS • 1-800-826-5432  
(IN CALIFORNIA: 1-800-258-6666)

AK, HI, OR INFORMATION • (213) 380-8000

- QUANTITIES LIMITED
- MINIMUM ORDER \$10.00
- USA \$2.50 SHIPPING NO C.O.D.
- FOREIGN ORDERS INCLUDE SUFFICIENT SHIPPING
- CALIF RES ADD 6.12%

# LISTEN UP!

Here's what you've been looking for – an all new hard-hitting monthly magazine which gives a unique insider's view of what's really going on in the world of communications. POP' COMM is your primary source of information – bigger and better than any communications magazine, with exciting coverage of scanners, shortwave broadcast & utility stations, spy stations, pirate and clandestine broadcasters, RTTY monitoring, survivalist communications systems, FCC news, wiretapping and bugging, voice scrambling/unscrambling, surveillance/undercover communications, satellite & cable TV, sophisticated telephones, & more. What you've been looking for all along! Take advantage of substantial savings over the newsstand price by subscribing now. Don't miss out on even one single issue of POPULAR COMMUNICATIONS – order your subscription now.

POPULAR COMMUNICATIONS SEPTEMBER 1984 \$1.00  
12 ISSUES CANADIAN  
War In The Mideast:  
Tune In On It!

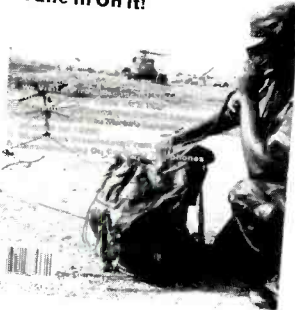

Twelve Issues \$14

# SUBSCRIBE NOW & SAVE!

## POPULAR COMMUNICATIONS

76 N. Broadway, Hicksville, NY 11801

Yes! The NEW POPULAR COMMUNICATIONS is just the magazine I've been looking for. Start sending it to me now! I understand that I may cancel at any time for any reason, and receive a full refund on my unused subscription.

Paid by:  Check  Money Order  MasterCard  Visa  
My account number is

\_\_\_\_\_

Name \_\_\_\_\_

Street \_\_\_\_\_

City \_\_\_\_\_

State \_\_\_\_\_

Zip \_\_\_\_\_

1 Year (12 issues) \$14.00  
Newsstand price \$23.40

2 Years (24 issues) \$25.00  
Newsstand price \$46.80

3 Years (36 issues) \$36.00  
Newsstand price \$70.20

Canada/Mexico — one year \$16.00, two years \$29.00, three years \$42.00 Foreign — one year \$18.00, two years \$33.00, three years \$48.00.  
Postmaster: Please send all address changes to POPULAR COMMUNICATIONS, P.O. Box 20406, Los Angeles, CA 90006.  
First-class Air Mail — one year \$71.00, two years \$139.00, three years \$207.00

CIRCLE 74 ON READER SERVICE CARD



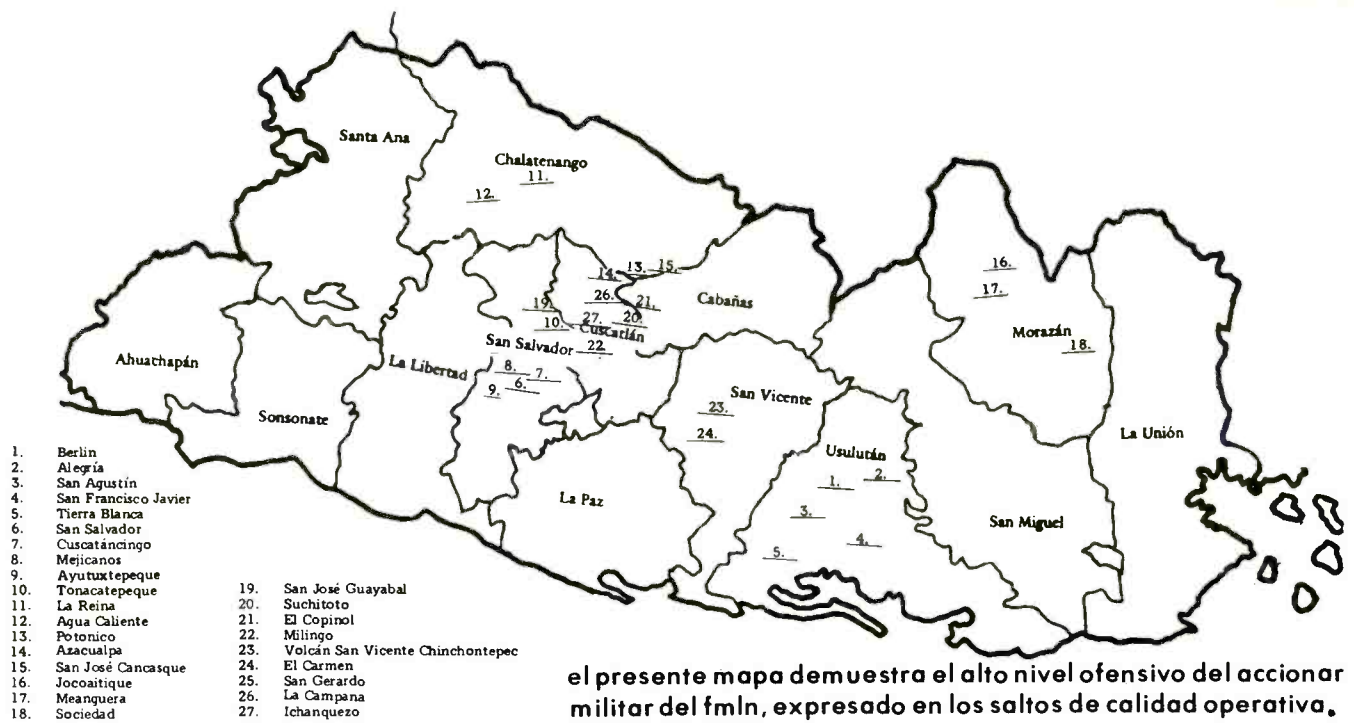

el presente mapa demuestra el alto nivel ofensivo del accionar militar del fmln, expresado en los saltos de calidad operativa.

# “We Will Win”

## Radio Venceremos: An Inside Look At A Rebel Broadcaster

BY OWEN WILLIAMSON

**D**uring the last three years, the word “venceremos” (“we will win” in Spanish) has become virtually synonymous with El Salvador for DXers and SWLs. Unlike the faintly-heard and usually uninspired government broadcasts from San Salvador or the still-experimental Radio El Salvador International, the rebel Radio Venceremos, “Official Voice of the Farabundo Martí National Liberation Front” (FMLN), has achieved media coverage and audience dedication that would be the envy of world-class shortwave broadcasters. Using variable frequencies in the QRM-free 6500-7000 kHz band, Venceremos puts a fairly strong signal into Central America and Mexico, northern South America, and the southern USA. Outside of this primary coverage area, Radio Venceremos has been reported by DXers from as far afield as Italy, Australia, and Japan.

Since its official inauguration on the evening of January 10, 1981, Radio Venceremos has grown from one outdated transmitter in a peasant hut to the Venceremos Radio System—a network of three shortwave and two FM outlets, several mobile

units, a semi-fixed VHF or microwave feeder system, and even a dramatic troupe and a “studio” band! The fact that all of this had developed in the midst of vicious guerrilla war and repression and in spite of government electronic and military countermeasures has to be counted as unique in the history of modern underground radio in this hemisphere. Radio Venceremos is a successful model of a “free radio” system existing and growing under the most adverse conditions imaginable.

The story of Venceremos did not begin with January, 1981. Commandante Luisa of the FMLN relates that the People’s Revolutionary Army (now part of the FMLN) has been seeking the means to put together an underground radio project since late 1978. Rebel leadership could not help but be impressed with the success of Radio Sandino, which was then transmitting underground Sandinista programs to Somoza’s Nicaragua. Also during this period, communications became a major problem for the Salvadoran left, as their access to mass media became restricted and distributing or even reading leaflets became dangerous to one’s health. It

was no longer practical to take over a broadcasting station at gunpoint every time a message or communique had to be released, and the need for a better way to communicate with the public was obvious.

So, in late 1979, guerrilla Commandante Jorge Melendez smuggled a Viking Valiant transmitter into El Salvador, and on January 22, 1980, “People’s Revolutionary Radio” went on the air in San Salvador on the standard broadcast band. Response from the public was favorable, but before long it became evident that the security necessary to sustain an underground radio on the air in an urban area could not be maintained indefinitely, and the radio was shelved after operators had a near brush with death in the person of Salvadoran government security forces.

On December 17, 1980, Commandante Joaquin Villalobos and a band of guerrillas under his command smuggled the transmitter into Morazan, in the remote northeast of the country. With the arrival of an “internationalist” technician known only as “Santiago,” test transmissions began. Some of these experimental broadcasts were made

under the ID of "Radio Farabundo Martí," a name later adopted by another Salvadoran clandestine. An observer who was there at the time described it: "... between the two of them ['Santiago' and a Salvadoran technician from San Miguel] they succeeded in making a transmission that could barely be heard in the immediate area, but which brought great joy to the encampment. It was a great day in Morazan."

Radio Venceremos was assigned the task of mass agitation for the January, 1981 guerrilla offensive and anticipated national uprising, while the enigmatic Radio Liberation, a completely separate operation, was assigned to serve as the rebel's official voice for the nation and the world. Venceremos' first program featured Commandante Villalobos' call to join the offensive, as well as a message from a Catholic priest, Fr. Rogelio Poncelle (who still appears frequently as a guest on Radio Venceremos).

While the "General Offensive" of January, 1981 failed to reach its over-ambitious goals, it did win breathing-space for Radio Venceremos in the hard months that followed. In March, 1981, 4500 government troops attacked Morazan with artillery, infantry, and air support. The Radio Venceremos camp fell after 20 days of fierce combat. But, the Venceremos team, transmitter, generator and all, escaped the government encirclement hours before the final drive. A member of the Venceremos team later described this as the station's "baptism of fire." The station suffered no casualties and was able to resume broadcasting in less than 48 hours. With the disappearance of Radio Liberation in April, 1981, Venceremos gained the title of "Official Voice of the FMLN" by default.

During the final months of 1981, radio amateurs had a unique opportunity when Radio Venceremos briefly opened on 14,500 kHz for SSB QSO's with radio amateur operators, for the purpose of "receiving messages of solidarity." There is no report that any North American ham ever worked Radio Venceremos (which would have been illegal in any case, on an out-of-band frequency). However, the Venceremos OP was not interested in discussion and would answer no questions. This chance to talk directly with a guerrilla combat radio operation ended in December when the war returned to Morazan.

December, 1981 brought the severest trial for Venceremos, and interested SWLs who were listening during that period remember reports of the station's destruction amidst a silence that seemed to last forever. Radio Venceremos was forced to leave the air on December 7, 1981, and did not return until December 24, 1981, after the death in combat of three members of the Radio Venceremos team and the loss of the original Viking Valiant rig.

The same offensive that almost finished off Venceremos also saw the destruction of the villages of El Mozote and Poza Honda, Morazan, with the death of over 1,000 non-combatant civilians. Back on the air with a



*Los Torogoces, the studio band that plays over Radio Venceremos.*

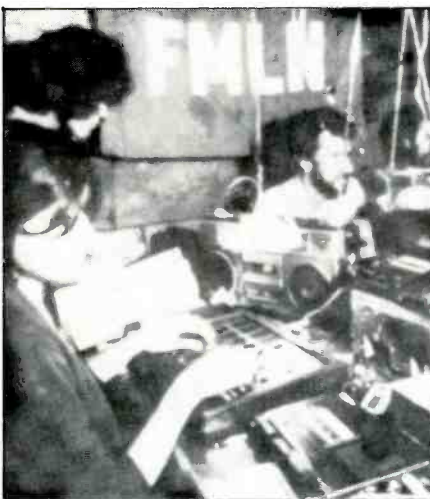

*Radio Venceremos at La Guacamaya.*

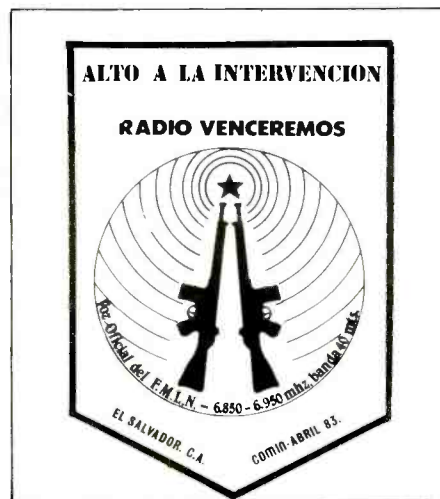

reserve transmitter, Radio Venceremos broke the story to the world media. U.S. and Salvadoran government sources denied the massacre, but U.S. reporters went to the scene at Venceremos' broadcast invitation and confirmed the story first-hand.

By January, 1982 the strategy of at least part of the FMLN was to prepare for an insurrection to correspond with the Salvadoran constituent assembly elections of March 28, 1982. The first months of 1982 featured some of the most dramatic programming ever heard on Venceremos, with live coverage of incursions into the cities, relays of broadcasts from occupied AM stations, and instructions for "people's militia" actions. Listeners during this period would hear the

call "Attention to the drums of insurrection!" followed by detailed instructions for preparing Molotov cocktails, homemade bombs, or neighborhood dispensaries. Housewives were instructed to stock up on basic foods and fuel, and employees were told to arrange guerrilla access to company-owned vehicles and equipment by duplicating or stealing ignition keys. All was in readiness...

But the call never came. The insurrection was to be sparked by the taking of Usulután City by FMLN columns, but the army and air force held Usulután, and the FMLN suffered a defeat that included the death of "Gonzalo," the commander of the Southeastern Front. So, the signal was never given over Radio Venceremos. Meanwhile, Radio Fara-



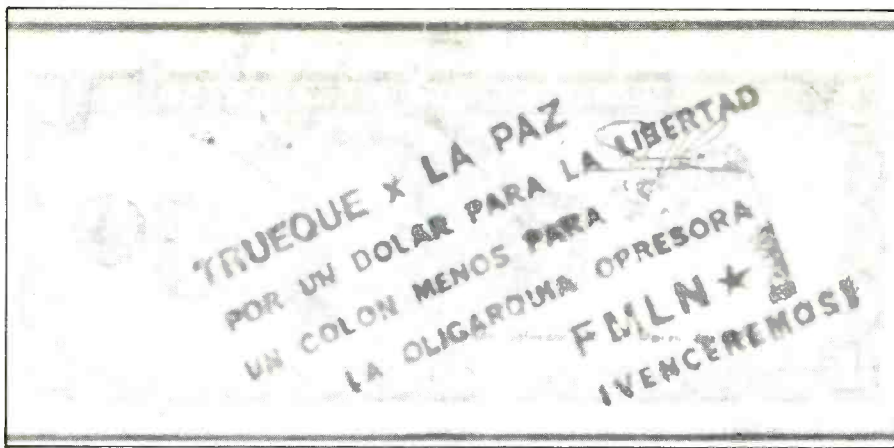

In addition to broadcasting, the FMLN people also stamp political propaganda on the back of Salvadoran currency.



bundo Martí of the FPL faction of the FMLN refused to call for or even mention insurrection, and a profound shakeup within the FMLN ensued. The songs, chants, and drums of insurrection vanished abruptly from Radio Venceremos as the FMLN did an about-face and opted for a Vietnam-style "prolonged people's war."

Radio Venceremos found it had an electronic war of its own to fight when, on March 24, 1982, it found its frequencies heavily jammed for the first time. This first jamming was of a high-tech variety with broadband characteristics, and guerrilla sources traced it to the *USS Caron* on station in the Gulf of Fonseca off Central America. Later efforts at jamming have been simpler and have been identified as coming from local sources. Typically, local jamming efforts have been badly-distorted musical transmissions one or two kHz off of the Venceremos frequency. The guerrilla radio, of course, declared itself a "guerrilla of the airwaves" and switched to variable frequency operation, ranging as high as 8000 kHz and as low as 6200 kHz, but finally settling on dual frequencies around 6580 and 7005 kHz respectively.

At times the jamming of Radio Venceremos has taken bizarre forms, as in November, 1982 when the jammers made a ham-fisted effort at "black" radio, first imitating Venceremos itself and then a supposed dissident fraction among the rebels. Unfortunately for the perpetrators of this scheme, they tried to combine jamming and black propaganda, and as a result their message

was lost between distortion and QRM with Venceremos. The effort was abandoned as its failure became evident. Jamming of Radio Venceremos has continued since on a sporadic basis, but with minimal success. However, occasional bouts of effective, obviously high-tech jamming have been noted and could resume in earnest at any time.

In late 1982 Radio Venceremos opened its first FM outlet on Guazapa Ridge, a permanent guerrilla stronghold within line of sight of San Salvador. Programming is relayed on captured government communications gear through an elaborate feeder system via guerrilla-controlled peaks in San Vicente, and is on the air daily at 2030 local time. Radio Venceremos-FM was silenced by government action in 1983, but returned to the air and by mid-1984 was on FM, 98.5 MHz nominal, with outlets covering east and central El Salvador.

In January, 1984, Venceremos also opened an 80-meter outlet, nominally "near 3.5 MHz" but actually closer to 3600 kHz, heard in North America with poor signals. As the areas under guerrilla control have grown, Radio Venceremos has gained more of the characteristics of a national radio system as opposed to those of a clandestine broadcaster. The daily newscast, "Plomo Informativo" (roughly translatable as "informative ammo"), covers news from guerrilla-controlled zones, plus world items not available from other Salvadoran media. The "Guacamaya Subversiva" radio drama troupe presents delicious political satire

ranging from supposed interviews with the U.S. ambassador to mock soap operas, complete with ads for the death squads. The "Torogoces" band plays Salvadoran country music with lyrics that urge people to join the rebels.

Sometimes a mood of deceptive normalcy descends on Radio Venceremos. Yet it is deceptive precisely because El Salvador is still very much at war, a war that has cost at least 40,000 lives since Venceremos went on the air. How is it that Radio Venceremos has survived while other clandestine broadcasters have gone under, some under far less adverse circumstances? Why is it that Venceremos has grown, while at least three other Salvadoran clandestines (Radio Revolucionaria del Pueblo, Radio Liberacion, Radio Unidad-Usulután) have been silenced?

Contrary to some reports that Venceremos survives by being outside El Salvador, every available evidence points to the fact that, as the rebels claim, it is the people of El Salvador who have kept Venceremos alive. According to Commandante Luisa, "Since its first broadcast, the radio has been in the midst of the masses, in a dialectical relationship with what we could call their 'operational capacity,' and their strength." Early on another FMLN leader had declared that in El Salvador, since there are no impassable jungles or mountain fastness, the people would have to be the mountains and jungles. According to the rebels, these are the mountains in which Radio Venceremos has been sheltered for more than three years, much more than the rolling Guacamaya hills of Morazan.

Rebel sources explain that at one time Venceremos was considered by the Salvadoran military as their prime objective in the Salvadoran east, but subsequent FMLN offensives and territorial gains have taken the "heat" off Venceremos. Venceremos is still the target of government air-strikes, and its transmitter sites regularly take shelling from long-range government artillery. US Air Force electronic surveillance planes have made repeated overflights to scan Venceremos operations, and at least twice the Nicaraguan "contras" have claimed to have destroyed Venceremos installations in Nicaragua (and Venceremos has learned about its supposed destruction only later). Yet, Venceremos survives, and makes the claim that "to silence Radio Venceremos would be to conquer the people."

Radio Venceremos sets as its future plans: "to inform and orient the masses and to publicize the struggle of the Salvadoran people on the international level by all possible means." Following the slogan, "The present is for struggle, the future is ours," Venceremos hopes to "create a basis for the future functioning of all the mass media in the period of reconstruction."

Requests for information about Radio Venceremos should be addressed to: Radio Venceremos, Apartado Postal 7-907, Mexico, DF, MEXICO. An official listener's magazine, *Senal de Libertad*, is available for \$1.50 per copy, from: ESIC, P. O. Box 28892, Oakland, CA 94604. **PC**



# ELECTRONICS BOOK CLUB

The Best Source for Hobbyists and Professionals  
for Over 18 Years!

Time- and Money-Saving Advice . . .  
Practical Troubleshooting & Repair Tips . . .  
State-of-the-art Technology . . . Hundreds  
of Projects . . . Plus, Exceptional Savings

## Select 5 Books for Only \$2<sup>95</sup>

values to  
\$107.25

THE TAB HANDBOOK OF  
**RADIO COMMUNICATIONS**

BY JOSEPH J. CARR, K4IVV

1636  
List \$45.00

**Counts as TWO Books!**

**BEGINNER'S GUIDE TO READING SCHEMATICS**



BY MARCY J. TRAISTER  
1536  
List \$14.95

**THE MASTER HANDBOOK OF ACOUSTICS**



BY R. ALAN EVERTS  
1296  
List \$18.95

**ELECTRIC MOTORS & CONTROL TECHNIQUES**



1465  
List \$15.95

**MAINTAINING & REPAIRING VIDEOCASSETTE RECORDERS**



1503  
List \$21.95

**32 ELECTRONIC POWER SUPPLY PROJECTS**



1486  
List \$17.95

**ROBOTS & ROBOTOLOGY**



1673  
List \$13.95

**Electronic Circuit Diagrams**



510  
List \$13.95

**HOW TO DESIGN/BUILD REMOTE CONTROL DEVICES**



1277  
List \$19.95

**Understanding Electronics**

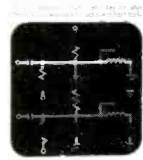

BY R. M. WOLFE  
1113  
List \$12.95

**1001 THINGS TO DO WITH YOUR PERSONAL COMPUTER**



BY MIKE GATVICH  
1160  
List \$14.95

**IC VOLTAGE REGULATOR SOURCEBOOK WITH EXPERIMENTS**



1557  
List \$14.95

**The Master Guide To Electronic Circuits**

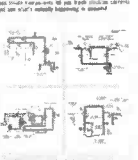

BY THOMAS M. ADAMS  
1184  
List \$17.95 (paper)

**BEGINNER'S GUIDE TO ELECTRICITY & ELECTRICAL PHENOMENA**



1507  
List \$15.95

**LASERS THE LIGHT FANTASTIC**



BY CLAYTON L. HOLMERS  
1108  
List \$15.95

**COMPUTER PERIPHERALS YOU CAN BUILD**



1449  
List \$19.95

**PRACTICAL MICROWAVE OVEN REPAIR**



1667  
List \$19.95

**THE BEGINNER'S GUIDE TO LASER, PIANOS, HOBBY GEN & OTHER WORKING MODEL PROJECTS**



BY MIKE J. EVERTS  
1604  
List \$21.95

**HOW TO DESIGN CIRCUITS USING SEMI CONDUCTORS**



BY WALTER B. MORTON  
1543  
List \$17.95

**DIGITAL AUDIO TECHNOLOGY**



1451  
List \$18.95

**THE MICRO COMPUTER BUILDER'S BIBLE**



1473  
List \$19.95

**THE BEGINNER'S BOOK OF ELECTRONIC MUSIC**



BY DECKEY HORN  
1438  
List \$18.95

**BUILD A PERSONAL EARTH STATION FOR WORLDWIDE SATELLITE TV RECEPTION**



1409  
List \$15.95

**FREE guide to mail order sources for electronic parts and components**  
A \$6.95 Value!

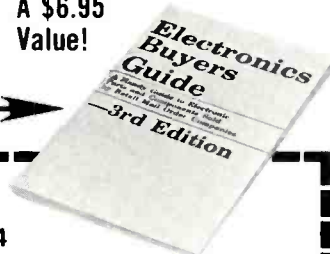

## FREE When You Join Now

### 7 very good reasons to join the Electronics Book Club

- **Big Savings.** Save 20% to 75% on books sure to increase your electronics know-how
- **No-Risk Guarantee.** All books returnable within 10 days without obligation at Club expense
- **Club News Bulletins.** All about current selections—mains, alternates, extras—plus bonus offers. Comes 13 times a year with hundreds of up-to-the-minute titles you can pick from
- **"Automatic Order."** Do nothing, and the Main selection will be shipped automatically! But . . . if you want an Alternate selection—or no books at all—we'll follow the instructions you give on the reply form provided with every News Bulletin
- **Bonus Books.** Immediately get a Dividend Certificate with every book purchased and qualify for big discounts of 60% to 80%
- **Extra Bonuses.** Take advantage of added-value promotions, plus special discounts
- **Exceptional Quality.** All books are first-rate publisher's editions selected by our Editorial Board and filled with useful, up-to-the-minute information

**ELECTRONICS BOOK CLUB**  
P.O. Box 10  
Blue Ridge Summit, PA 17214

Please accept my membership in the Electronics Book Club and send the 5 volumes circled below, plus, my FREE copy of *The Electronics Buyer's Guide*, billing me \$2.95 plus shipping and handling charges. If not satisfied, I may return the books within ten days without obligation and have my membership canceled. I agree to purchase 3 or more books at reduced Club prices (plus shipping/handling) during the next 12 months, and may resign any time thereafter.

510 1108 1113 1160 1184 1277 1296 1409  
1438 1449 1451 1465 1473 1486 1503  
1507 1536 1543 1557 1604 1636 1667 1673

Name \_\_\_\_\_ Phone \_\_\_\_\_  
Address \_\_\_\_\_  
City \_\_\_\_\_  
State \_\_\_\_\_ Zip \_\_\_\_\_

Valid for new members only. Foreign applicants will receive special ordering instructions. Canada must remit in U.S. currency. This order subject to acceptance by the Electronics Book Club, PCM10 84

CIRCLE 63 ON READER SERVICE CARD





The Penn Albert Hotel in Greensburg, Pennsylvania sports a couple of radio towers in this 1949 view.

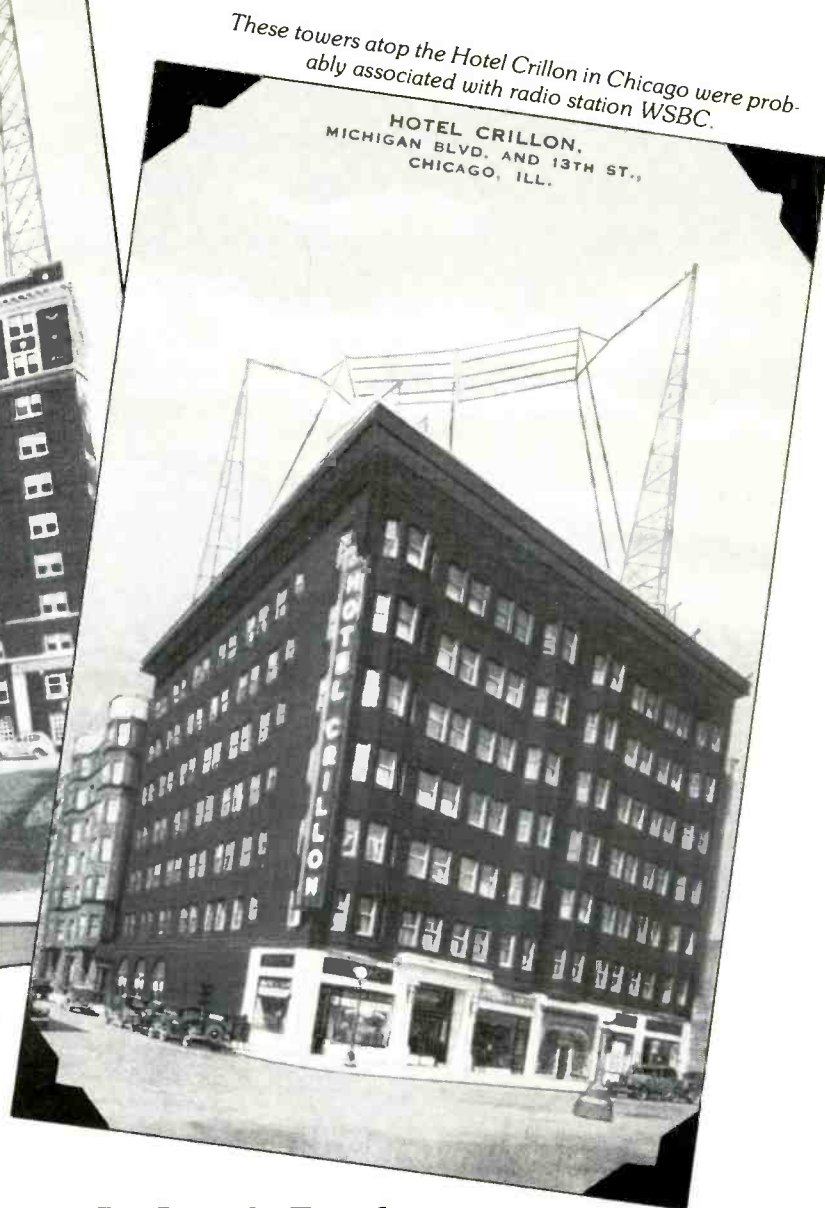

These towers atop the Hotel Crillon in Chicago were probably associated with radio station WSBC.

**Here's An Inexpensive Way To Look Back  
Into Broadcasting's Golden Past**

# Radio History – Via Picture Postcards

BY ALICE BRANNIGAN

**I**n the June *POP'COMM* there was a great story about DX'ing with a camera in order to capture on film the fast-fading radio relics of the past. I have my own approach to this and I don't use a camera. Instead, I go to flea markets and collectors' conventions and head straight for the first dealer I see offering

old picture postcards. I do this because I've learned that radio history can often be found on postcards, and it is usually something that can no longer be captured with a camera.

Over the years I've put together what I feel is an interesting assortment of (mostly) broadcast related radio history via these

postcards. Just to give you an idea of some of the cards I've collected, I have a couple to show you.

One card, for instance, shows the Penn Albert Hotel in Greensburg, Pennsylvania. The card is postmarked 1949 and shows two towers on the roof. The towers look to



Anybody know what these towers were for on the U.S. Grant Hotel in San Diego?

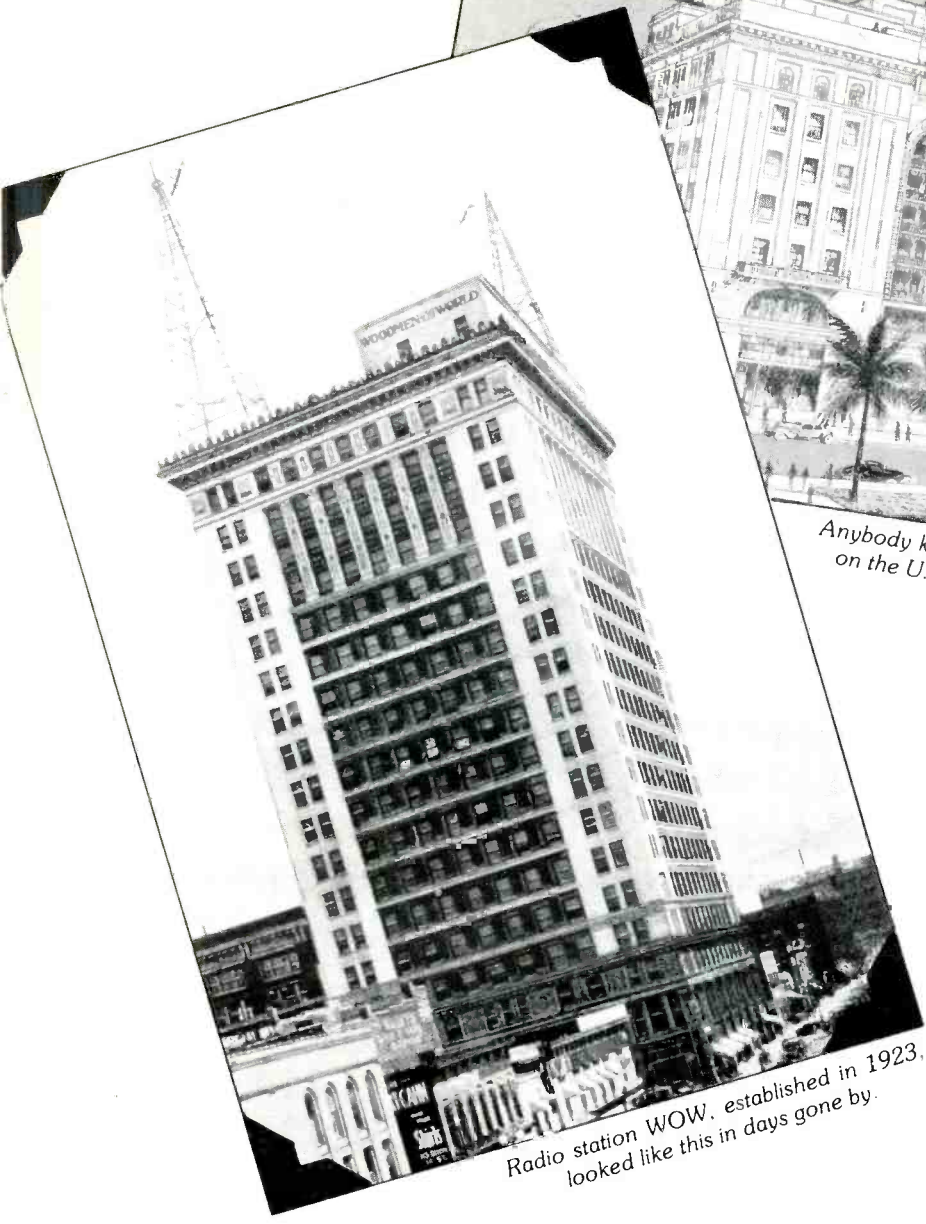

Radio station WOW, established in 1923, looked like this in days gone by.

well-known station WOW in Omaha, Nebraska. This station went on the air in 1923 and is a genuine broadcasting pioneer, still going strong after more than 60 years. The postcard shows its antenna towers atop the WOW Building, showing the words "Woodmen of The World" on the small structure on the roof. In 1930 WOW was on 590 kHz with 1 kW. A 1946 listing shows it running 5 kW. That listing gave the station address as the Insurance Building, 17th and Farnam Streets, with the transmitter at 5500 Kansas Avenue. This station now runs 5 kW and shows an address of 11128 John Galt Blvd.

The final card I have room to display here is a bit of a mystery to me. It shows the U.S. Grant Hotel in San Diego as it appeared in 1945. Atop the hotel are two broadcasting towers which seem to be about 50 or 60 feet in height, with a series of wires running between them. Radio listings for 1946 show only three broadcasters in San Diego—KFMB, KFSD, and KGB—none with an address at a hotel. Of course, I don't know the address of the U.S. Grant Hotel and it doesn't appear to be currently in business (at least not under that name). If any readers can identify the station in the photo, why not let me know?

Sorry that I don't have room here to show you additional glimpses of some of these historic broadcasters. Maybe in future issues I'll be able to let you see more of them. I just wanted to make readers aware that postcard dealers (and there are plenty of them) sell these to collectors for only 25¢ to 50¢ and they are interesting to collect if you're into radio history. Dealers may not have a "radio" or "broadcasting" category to look through, but you can usually find some under "hotels" and "office buildings." **PC**

be about 100 feet each and there's a wire shown strung between them. Looking in reference books I found that the only broadcaster ever to exist in Greensburg was WHJB and that station went on the air in 1934 (620 kHz with 250 watts). In 1946 it was listed as being owned by the Pittsburgh Radio Supply House, with studios and transmitter at 128 North Pennsylvania Avenue. WHJB is still in operation, now from 245 Brown Street, and running 2500 watts days, 500 watts at night. I would assume that my postcard represents the station as it appeared 35 years ago.

Next we have the Hotel Crillon, Michigan Avenue and 13th St., in Chicago "directly opposite the main entrance to A Century of Progress, one block from I.C. and Big 4 Railroad Station and Union Bus Depot."

The card isn't postmarked or dated so there's no easy way to determine a specific time frame for the photograph showing the elaborate radio transmitting antennae on the roof of the hotel. Checking back through old broadcasting records makes it look like this may have been WSBC, which went on the air in 1925. In 1930 it was owned by the World Battery Company and running 100 watts on 1210 kHz from 1250 South Michigan Avenue. In 1946 the station had moved to 2400 West Madison St., and more recently the station is listed at 4949 West Belmont and sharing the use of its frequency (now 1240 kHz) with two other 1 kW broadcasters. My assumption is that the postcard depicts WSBC prior to its move to West Madison Street.

Then there is an undated card showing



## ESTABLISHING SURVIVALIST COMMUNICATIONS SYSTEMS

### CB Or Not CB?

Cost is only one consideration to be grappled with by those planning or establishing an emergency communications system or network. Other factors include ease of obtaining, operating, and servicing the equipment as well as its service reliability. Not all pieces of communications equipment meet these challenges with flying colors, and very often it comes to pass that the would-be communicator comes to the decision that CB radio (remember CB?) is probably the best bet. Well, it has its points. However, there are a few things which should be kept in mind before you herald CB as the greatest invention since Oreo Cookies with Double-stuff. For the uninitiated, a quickie summary of the past and present of CB is in order.

CB got started in a serious vein in the late 1950's. The FCC's idea was to offer the public a chance at inexpensive two-way communications with a minimum of licensing requirements. Rules and regulations were established that specified a service calling for short range business and personal communications over any of 23 different channels set up between 26.965 and 27.255 MHz. Clearly, the FCC did not intend for the CB service to be a no-license quasi-Ham radio band. A number of manufacturers, such as Globe, International Crystal, Heath, Knight-kit, Vocaline, and RCA were on hand to supply transceivers for those who wanted to use the 5-watt transceivers.

Inasmuch as the opening of this band was inadvertently coincidental with a portion of the sunspot cycle which was producing spectacular skip (distant) communication opportunities, it didn't take very long for the licensees to realize that it offered plenty of opportunities for meeting and chatting with new found friends across the nation. The FCC reacted in horror and annoyance and carefully pointed out that the CB operators were not aware that the rules of the road did not permit casual chit-chat with random stations. CB was supposed to be a somewhat serious service to be used for dispatching delivery trucks and for husbands to call home to say that they would be late for dinner because they were stuck in traffic. No matter, the CB service was marching to the beat of a different drummer and at least 95% of those getting on the air were doing so because they perceived the possibilities of operating what was essentially and for all purposes a "no-license ham band."

The popularity of CB radio was, however, still in its very early stages and despite the fact that many new manufacturers came into the market, for almost 15 years CB was hardly a household word. Things changed



Here's the 27 MHz set-up used by Dave in Indiana. Dave is into SSB.

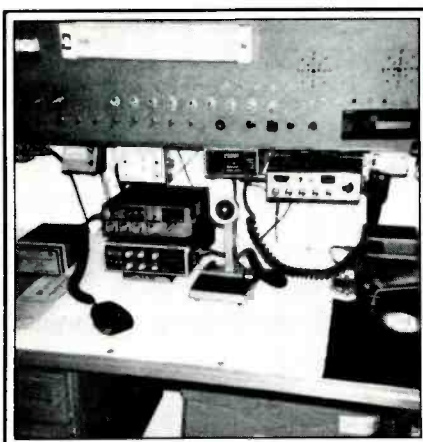

POP'COMM reader Anton Venter of the Republic of South Africa is active on 27 MHz and reports that it covers all of his radio needs. Here is his radio room.

in the mid-1970's when, thanks(?) to a couple of popular songs about truckers talking on CB radio, the radio service was skyrocketed into the public eye. More songs came along, followed by CB movies, CB T-shirts, CB socks, and practically every other product one could imagine from toothbrushes to cornplasters.

Everybody wanted to "get on CB" and, of course, there was a panic to produce, im-

port, merchandise, and buy CB transceivers and accessories. Those operators who had been quietly and peacefully using the channels in earlier days were horrified to witness this assault upon their orderly channels by literally millions of new operators in a howling crunch of humanity! The "new breed" of CB operators was seen as rude and generally uninterested in learning or bothering with any of the long-established traditions (even those that continued to irritate the FCC) of those who had been using the band. The operators who jammed onto the channels instituted a whole new type of operation which incorporated its own unique so-called "CB lingo" (which was not in use prior to the mid-70's), the use of CB "handles," and other major and minor delights. The channels were a shambles but the industry was rolling along at high speed with at least 300 different manufacturers and importers trying to serve this market with transceivers, antennas, cable, microphones, slide mounts, and whatever. By 1977 the FCC allocated additional channels to CB in an effort to ease the overflow conditions. At that time, channels between 27.265 and 27.405 MHz as well as 27.235 and 27.245 MHz were added (Channels 24 through 40).

CB, however, had already begun to wind down from its "fad" era and a steadily decreasing number of new stations were taking to the airwaves. By 1978 the CB industry

had begun to feel the pains of diminished sales and by 1980 the CB market was rather desolate, with all but a few of the manufacturers still bothering with the band and its inhabitants.

Since that time there has been sufficient interest in CB to warrant the continuing participation of manufacturers such as Midland, Cobra, Uniden, and Radio Shack making standard base/mobile transceivers, plus a larger group producing smaller mobile transceivers primarily intended for standby or emergency use.

The CB channels themselves should be viewed in several categories. There is an emergency channel (Channel 9) which is supposed to be used by those having mechanical trouble on the road or by persons seeking road directions; mostly it is misused and many REACT teams that were monitoring there in the 1970's no longer seem to be as active or efficient as they once were (although some isolated teams still do a good job). Then there is the mobile in-transit channel (Channel 19) which has become popular with vehicles driving on the Interstates and other highways; it is still useful to monitor while traveling. Channel 16 and those between 35 and 40 are primarily used by SSB (single sideband) operators, while all others used for transmissions in AM mode.

Last year the FCC did away with individual CB licenses, although they did retain the rules and regulations governing CB operations. While FCC assigned station call signs

no longer are required, regulations relating to skip-working, power output, and other aspects of operation are still in effect and are currently being vigorously enforced by the FCC. In fact, during the past few months the FCC has cracked down on flagrant rule violators to a far more significant degree than had been noted for several previous years. That means that the channels have gotten a lot quieter and many of the more annoying and noisy stations are off the air. It may well be that this is a pretty good time to give consideration to taking a new look at the possi-

bilities of using CB for serious communications use.

AM equipment is more moderately priced than SSB gear, although SSB does offer a generally greater communications range and less-crowded channels. SSB operators, however, do not use 10-Codes, CB-lingo, or CB "handles," and that alone offers some of its own appeal. In any event, AM or SSB, CB isn't what it was several years ago—it is now one of the better deals in communications since its wacky "fad" years are in the past. Check it out. **PC**

## IC-R71A

**The Best Just Got Better  
The Superior Grade Communications Receiver . . .  
at a price you can afford!**



**Special  
\$649.95**

VISA

MasterCard

**For your discount price on ICOM and other major brands call 812-422-0231, 0252**

**220 N. Fulton • Evansville, IN 47710**      **MON-FRI 9AM-6PM**  
**ICOM & WILSON Commercial Equipment Available**      **SAT 9AM-3PM**

Please send all reader inquiries directly.

# ★ ★ CAN YOU? ★ ★

- Electronically listen thru any wall?
- See in the dark cheaply?
- Read thru an envelope with a \$1.00 chemical?
- Obtain UNLISTED TELEPHONE NUMBERS?
- Open virtually any LOCK OR SAFE in seconds?
- Ditch or tail anyone?
- Beat the lie detector and the PSE?
- Run a driver's license/vehicle check?
- Trace anyone, anywhere?
- Save 30% 500% on the best surveillance gear?
- Get birth death and real property records?
- Run a 50 state credit check?
- Alter common objects into surveillance gear?
- Beat private detectives at their own game?
- Perfectly scramble any conversation?
- Defeat bug and recorder detectors?

*The First Encyclopedia Of CIA Type Tricks*

## HOW TO GET ANYTHING ON ANYBODY

— LEE LAPIN —

Can 10,000 private investigators, police chiefs, intelligence agents (from both sides of the fence), embassies news reporters and the internal security forces of several mid-eastern countries all be wrong?

".. The most dangerous book ever published," -NBC newscaster, "one hell of a book, for the first time ANYONE can access the secret data banks and devices of the sophisticated powers"-National News Service, "the private eye's bible"; Association of Private Investigators, plus rave reviews in everything ranging from consumer publications to Police Times .

NOW AVAILABLE TO THE GENERAL PUBLIC!! Now you can actually understand/use or protect yourself from becoming a target of any intelligence campaign. Hard and fast data from skip tracing to state of the art surveillance!!!

**At Better Bookstores Everywhere - OR**

## ORDER TODAY BY MAIL OR TOLL FREE TELEPHONE!!

VISA MC ORDERS ONLY 800-345-8112 in PA 800 662 2444 or mail \$29.95+\$4 00 postage to Auburn-Wolfe Co. Box 623 Holmes Pa 19043 Dept 50.



## DX, NEWS AND VIEWS OF AM AND FM BROADCASTING

**F**irst off this month I want to continue my thoughts about FM DXing. When tuning for FM DX, the first thing to remember is to turn the AFC switch to off. The AFC is stronger on some receivers than others and will cause the set to jump from strong local to strong local. This will cause you to miss several channels in between.

The serious FM DXer will install an outside FM yagi antenna with 5 to 16 elements. It will be necessary to use a rotator with this type of antenna. Whether or not you use a preamp and what type depends on several conditions.

The very "best" system is an antenna strictly for the FM band (not a combination TV/FM antenna). Match this with a mast mounted preamp (the preamp mounted next to the antenna); then connect this to a 75 ohm coaxial lead which attaches to the antenna terminals on the FM receiver (300 ohm shielded twinlead may also be used).

The following are some of the variables from the "best" system. Living close to an FM (or TV) station will present a problem if you want to use a preamp. Actually, if you have a quality FM receiver, a preamp may not be a necessity. Using a quality yagi type antenna without a preamp will give a big boost to any receiver. As a matter of fact, adding a preamp in front of a top notch receiver will degrade the reception. About the only exception would be if you had a long length of cable from the antenna to the receiver—at least a few hundred feet.

If you live within about 5 miles (rough figure) of an FM station, a preamp is apt to be "overloaded" by such a strong signal. When this happens, you hear all kinds of crazy things on your radio. If the preamp does not overload, the receiver may, with the same result.

It is hard to generalize about an antenna system for everyone's situation, but I'll try.

The yagi type antenna will improve any FM DXer's station. The more elements the yagi has, the sharper the beam (see Figure 1). The sharper the beam, the easier to separate or null stations from one another. For example, if you had two stations on the same channel 100 miles from you but in opposite directions, they would both be unlistenable, depending on their power. With a yagi antenna, either station could be heard by facing the antenna to the city of the station you want to hear. Another example would be to turn the side of the yagi to the station you don't want to hear with the front aimed (hopefully) toward the station you are seeking. The important part is to put the "unwanted" station in the minimum pickup area of the antenna rather than maximizing the wanted station. Of course, if this doesn't produce the desired result, try the reverse!

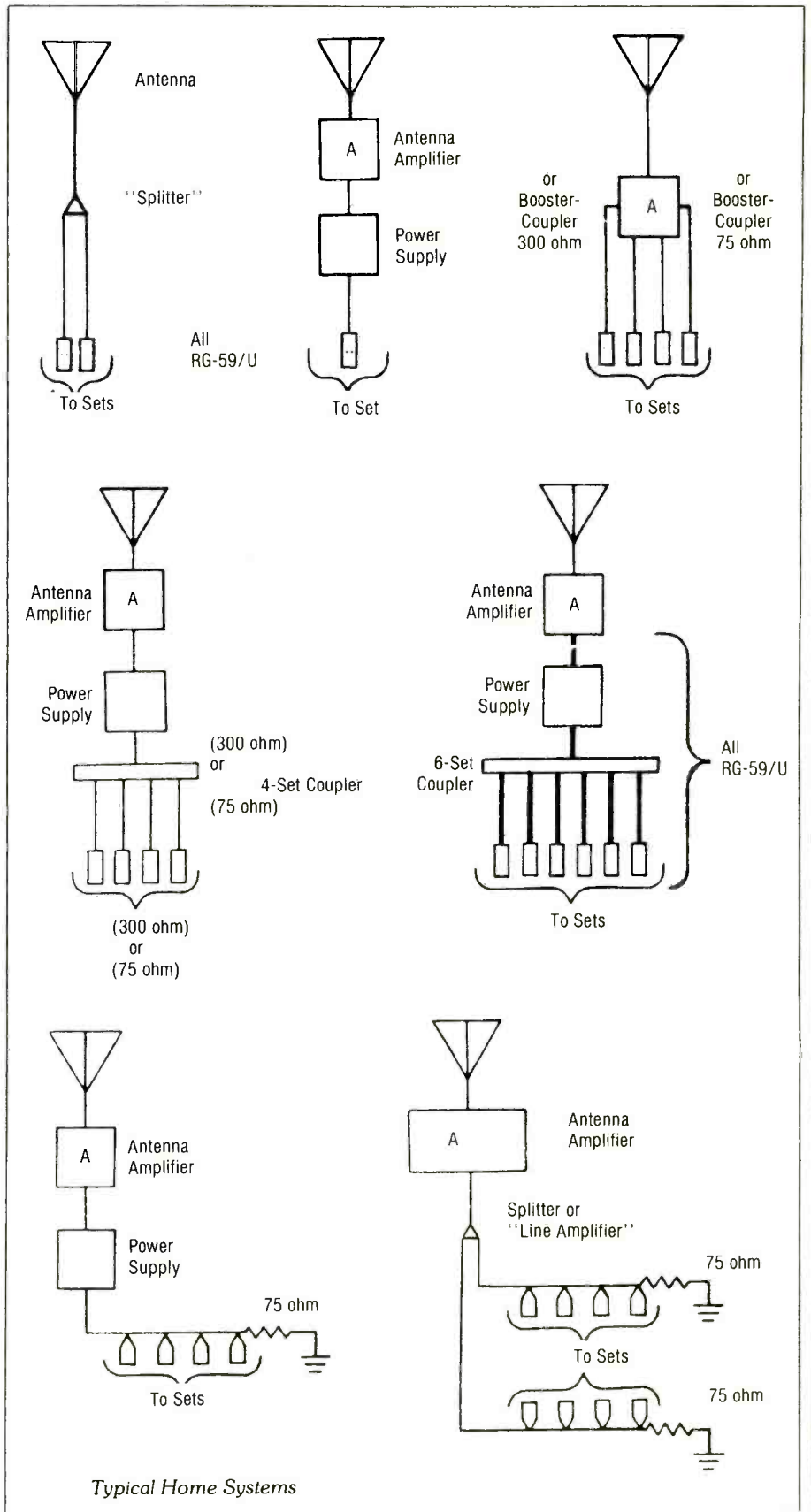

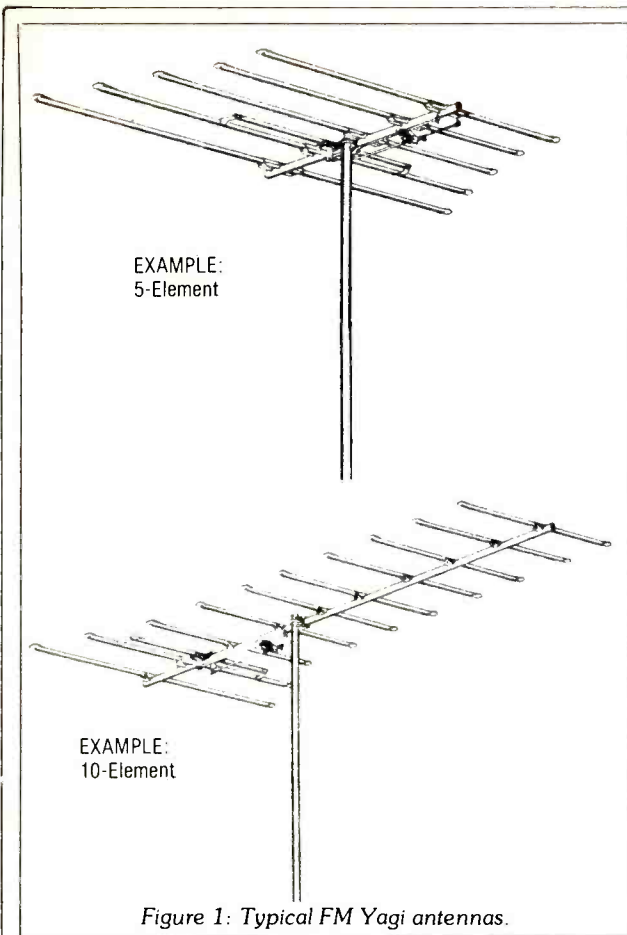
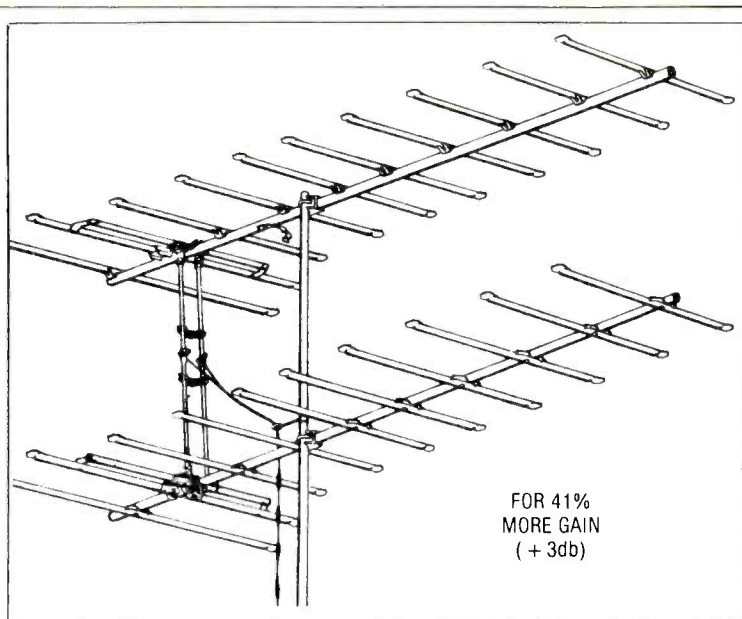

Figure 1: Typical FM Yagi antennas.



"Stacked" antennas must be the same type and increase the gain. This may reduce the need for a preamp.

but the loss is more than made up with the gain of the antenna.

Ask questions of people near you before you spend a bundle of money on an antenna system that won't do what a less expensive system would. Ask several people and average the answers! As a last hope, drop a letter to me at the address shown at the end of the column.

One other word before going on. If you have more than one receiver, remember, every time you split the signal with a two-set coupler, you lose 41% (3 dB) of the signal. This may require the use of a preamp (here we go again) to recover the losses if several receivers are connected to the same antenna. When you buy a preamp, compare and ask questions about the preamps available to you. The highest gain is not the most important specification to consider, but noise figure and overload limits are. I would only consider preamps made for the FM band. Don't bother with TV preamps unless you are using a TV/FM antenna and TV sets are on the same antenna. A TV preamp will allow many unwanted signals to be presented to the antenna terminals of the FM receiver. This allows the possibility of intermodulation and other spurious signals being heard where they shouldn't be.

I guess you've waited long enough, so here is the answer to last month's trivia question. "WBC" on the mike boom in the picture of the 1965 studio of WBZ stands for Westinghouse Broadcasting Company, owner of WBZ in Boston.

Well, if you started as a new BCB DXer last month, there should be quite a few stations on the log by now. You should have also discovered several tricks for catching a few "difficult" stations. A number of stations can always be heard at sunrise to two hours after sunrise and from near sunset until about an hour after sunset.

My favorite time for DXing, although I'm

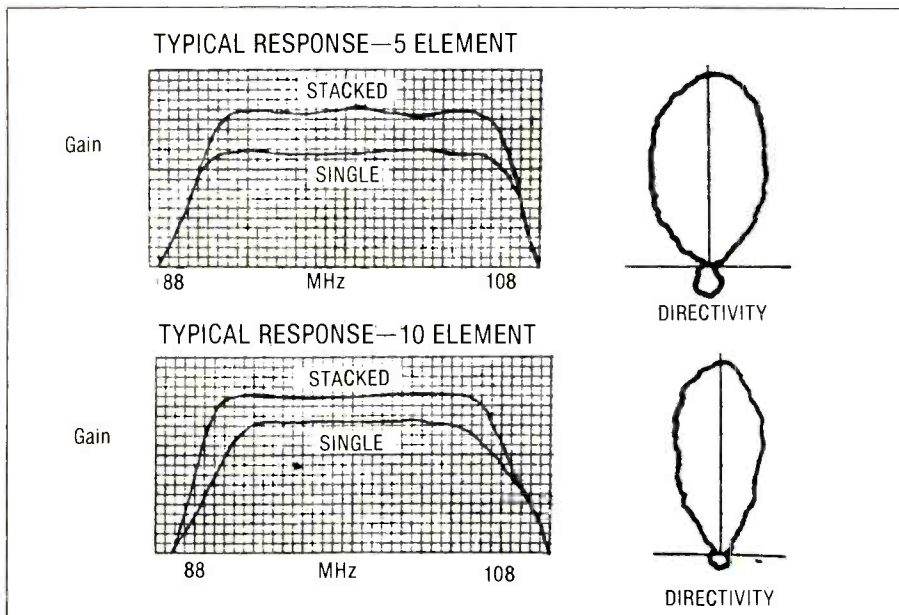

Beam patterns for yagi antennas. The 10 element has a sharper "nose" and less pickup from the sides and back. Stacking antennas means putting antennas one on top of the other.

Getting back to the preamp again, they can be a hindrance more often than a help in a metropolitan area. My suggestion is to make a provision to install a preamp after the antenna system has been tested and used a while without a preamp, except as noted before. Even if you live 50 or more miles from the nearest FM station, a preamp may not be necessary. Today's receivers are very sensi-

tive and may be more sensitive than the preamp you might buy. By using a preamp that is less sensitive than your receiver, you are degrading the reception ability of the receiver. The signal meter may be reading higher, but what are you hearing? The signal ("S") meter may be showing noise, not signals. The cable between the antenna and receiver does introduce a loss into the overall system,



# GILFER SHORTWAVE "BEST SELLERS"

New 6th Edition

## "Confidential Frequency List"



Now including RTTY frequencies. O. Perry Ferrell's ultimate utility listing. Detailing over 12,500 stations, by frequency. Every important AM, CW, FAX, RTTY and SSB station included.

**\$13.95+\$1.00 UPS**

## DATONG Active Antennas



**INDOOR — AD-270**  
3-meter dipole, low noise amp, 13' downlead, flat response from 200 kHz to over 30 MHz, 12 db gain, with cable, converter, hardware (specify lugs, RCA phone or PL-259 connector).

**\$124.50+\$5.00 s&h**

**OUTDOOR — AD-370** with stainless steel whips; mounts to any flat surface; with converter and 26' cable. **\$144.50+\$5.00 s&h**

**Basic or Modified Receivers:** Yaesu, Japan Radio, NRD-515, ICOM R-71A, Bearcat, Sharp, Sony & Panasonic.

# GILFER SHORTWAVE

International Radio Specialists

P.O. Box 239 Park Ridge, NJ 07656 U.S.A.

Phone (201) 391-7887

CIRCLE 141 ON READER SERVICE CARD

rarely up, is early morning. The band is the quietest at this time and the night time skip is still present to some degree. This is an excellent time to catch the daytimers that operate on clear channels. Starting at sunrise for an hour or so you should be able to hear the daytimers if you don't live too close to the clear channel station. Let me illustrate with an example. I live about 150 miles from New York City. Against WNBC on 660 kHz, it's not unusual to catch WESC in Greenville, SC. I have also caught WRRZ in Clinton, NC against WCBS on 880 kHz, even though RRZ is only 1 kw. Try some for yourself using these examples: If you live between St. Louis and Washington, DC., try WUST and KMOX on 1120 kHz; between California and Iowa, which is a pretty long stretch, try KFI and WOI on 640 kHz. Whether or not you have tried this technique before, let me know how it works out for you. Don't expect results every time you try it . . . this is part of the fun of BCB DXing! By the way, I was using the Panasonic RF 1170, which is a nice (\$180) portable radio (1976 vintage) with a rotatable loop on top. It doesn't take a very fancy radio!

The other end of daytime—sunset—finds another trick most DXers pick up quickly; listening to local daytimers sign off and seeing what is heard on the channel immediately afterwards. Also, listen on other daytime channels at sunset to catch the sign off. Another sunset trick is to listen for stations on regional and clear channels to the east of

you that become directional at sunset and reveal a station to the west of your location which is still operating under daytime parameters. This is because of a later sunset or a different time zone. This could work at sunrise for those of you who live to the west of a time zone. It would be possible to pick up stations signing on even though it is still dark where you are. I can't speak of this first hand since I've always lived in the Eastern time zone!

## FCC News

KWOD (FM), Sacramento, California, has been notified of an apparent liability for forfeiture of \$10,000 for apparent violation of sec 73.317(a)(14) for spurious signal emission on February 23 and 24, 1983 and for overmodulation on the same dates.

WNAB of Bridgeport, Connecticut, apparently did not maintain consistent rates for the politicians in the area. The FCC is seeking \$5,000 for apparent repeated violation of sec 73.1940(b).

KIPR and KIPR-FM of Lufkin, Texas, has been cited for apparent failure to calibrate the metering system at the station, not making performance measurements in 1982 and not making daily tower light observations. These violations could cost the stations \$750.

And two stations, WXIC of Waverly, Ohio, and WDNH-FM of Honesdale, Pennsylvania, moved without telling the FCC!

## Call Letter Changes

Old Call AM	New Call	Location			
new	KKEN	Kenai, AK	new	KLUX	Robstown, TX
new	KVLA	Ridgecrest, LA	new	KHAZ	Hays, KS
new	WKBH	Holmen, WI	new	KTRZ	Riverton, WY
new	WALY	Gray, KY	new	KUOO	Spirit Lake, IA
WKLM	WAAV	Leland, NC	new	WRGN	Sweet Valley, PA
WKAI	WLRB	Macomb, IL	new	KIVA	Sante Fe, NM
KNCI	KYCS	Boerne, TX	new	KDEP	Durant, OK
WWHK	WBRB	Mt. Clemens, MI	new	WYOB	Jax, IL
WMVM	WUPY	Ishpeming, MI	new	KGID	Giddings, TX
KGDN	KCIS	Edmonds, WA	new	KSMT	Breckenridge, CO
KHDN	KYTY	Hardin, MT	KLGT	KWXX-FM	Hilo, HI
WAGR	WTSB	Lumberton, NC	KWXX	WBMS	Wilmington, NC
WTSB	WAGR	Lumberton, NC	WAAV	WKAI	MacComb, IL
WFTE	WCFY	Lafayette, IN	WKAI-FM	WPBM-FM	KWOC-FM
WEXM	WKRE	Janesville, VA	WPBM-FM	KBLI-FM	KLCE
KYOU	KGRE	Greeley, CO	KBLI-FM	WCGY	WCGY-FM
WPJS	WORC	Orangeburg, SC	WCGY	KRIZ	KCKN
KISD	KMFR	Phoenix, AZ	KRIZ	KBGX	Roswell, NM
WEAT	WCGY	W. Palm Beach, FL	KBGX	KYYX	Alturas, CA
KCRI	KWHA	W. Helena, AK	KYYX	KKMI-FM	Seattle, WA
KRNS	KZZR	Burns, OR	KINE-FM	KDUV	Kingsville, TX
WDJD	WJCO	Jackson, MI	WWWJ	WZZT	Johnstown, OH
KKCI	KCXL	Liberty, MO	WGMZ	WCRZ	Flint, MI
KTLC	KTFI	Twin Falls, ID	KJMD	KAYO-FM	Aberdeen, WA
KXQR	KXTC	Clovis, CA	KCBI	KCBI-FM	Dallas, TX
KXLF	KCEZ	Butte, MT	WTGI	WKJN	Hammond, LA
KGOE	KMDY	Thousand Oaks, CA	KXRC	KRAI-FM	Craig, CO
			KDTA-FM	KLDR	Delta, CO
			KRTM	KRRR	Temecula, CA
			WEXM-FM	WKRE-FM	Exmore, VA
			KROG	KVML-FM	Sonora, CA
			KGRE	KYOU	Greeley, CO
			WFBB	WPTS-FM	Pittsburgh, PA
			WORC	WORC-FM	Orangeburg, SC
			KTOR	KLLR-FM	Walker, MN
<b>FM</b>					
new	WZTT	Rhineland, WI			
new	KQMA	Phillipsburg, KS			

## Station Updates

Frequency	Call	Location	Change
<b>AM</b>			
650	new	Clinton, MA	10/10 DA-2
670	new	Jefferson, GA	1 kw DA-D
770	new	Buchtel, OH	.25 kw D
810	WPED	Crozet, VA	increase from .5 to 1 kw D
870	new	Colonial Heights, TN	5 kw D
970	KPUA	Hilo, HI	change to 670 kHz, 10 kw
980	new	Kenai, AK	1 kw
1010	KRKX	Milwaukee, OR	new
1110	new	Oak Harbor, WA	.5 kw D
1150	KQQQ	Pullman, WA	add DA-N, .5 kw
1170	new	Hanceville, AL	.5 kw D
1180	new	Trion, GA	5 kw D
1230	new	Gatlinburg, TN	1/ .25 kw (WSMM)
1290	WDGS	New Albany, IN	add 1 kw night, DA-2
1470	KWRD	Henderson, TX	increase from .5 to 5 kw
1480	WCNS	Latrobe, PA	add night, 1 kw DA-2
1520	new	Greenup, KY	5 kw D
1550	KLFJ	Springfield, MO	increase from .5 to 5 kw
1550	KVKG	Solvang, CA	permit cancelled
1570	new	Holmen, WI	1 kw D
1590	new	Gray, KY	.5 kw D
<b>FM</b>			
88.5	WMNF	Tampa, FL	ERP to 100 kw, 520'
89.1	KUFM	Missoula, MT	ERP to 32 kw
89.5	new	Canton, NY	18 kw, 302'
90.7	new	N. Charleston, SC	10 kw, 443'
90.9	new	Hazard, KY	50 kw, 1190'
90.9	WEYS	Institute, WV	change to 13 kw, 428'
92.9	KSPZ	Colorado Springs, CO	ERP to 83 kw
93.3	WWSE	Jamestown, NY	ERP to 26.5, 643'
94.1	WMLW	Watertown, WI	ERP to 50 kw, 476'
94.7	WFME	Newark, NJ	ERP to 37.2 kw
95.1	WRBS	Baltimore, MD	HAAT to 500'
96.9	WHYW	Braddock, PA	ERP to 44.7 kw, 530'
98.3	KDAK-FM	Carrington, ND	Change from 97.7
98.5	KHYS	Pt. Arthur, TX	ERP to 100 kw, 417'
98.5	KDNO	Delano, CA	HAAT to 500'
98.7	new	Truth or Consequence, NM	37 kw, 2644'
99.3	new	Block Island, RI	3 kw, 300'
99.5	KRLB	Lubbock, TX	ERP to 100 kw, 589'
99.5	KZZL	Le Mars, IA	HAAT to 1000'
100.1	WJLQ	Pensacola, FL	HAAT to 1598'
101.5	WKHX	Marietta, GA	HAAT to 968'
102.1	KYYS	Kansas City, MO	HAAT to 1000'
104.1	KXYL-FM	Brownwood, TX	ERP to 74 kw, 1599'
105.3	WKPQ	Hornell, NY	ERP to 43 kw, 530'
105.5	KRRI	Boulder City, NV	HAAT to 1477'
105.7	WQXA	York, PA	ERP to 46 kw
106.5	WMAR-FM	Baltimore, MD	ERP to 37 kw non-directional
107.5	KGOL	Lake Jackson, TX	HAAT to 990'

WXIC changed from a directional antenna system to a non-directional system, according to the FCC. The apparent forfeiture to WXIC is \$5,000 and \$4,000 to WDNH-FM.

The notice of fines and violations is edited to make it of interest to our readers and BCB DXers. The information is reprinted for comparison with your logs so you may see if the station was operating at variance when you were listening. Others are to give some insight into the internal operations of a broadcast station. It is not intended to embarrass any station or city.

Trivia question: What ever happened to the small triangles that used to be on all AM radio dials at 640 and 1240 kHz? (CONELRAD, anybody?)

Station to monitor this month is WBAP in Fort Worth, Texas. They are 820 kHz. The station is another old-timer; drop me a note and tell me how well you can receive them. The address for all correspondence is P.O. Box 5624, Baltimore, MD 21210,0624.

Lots of updates this month. While I'm explaining, please keep in mind that these updates are subject to change. **PC**

## CLANDESTINE CONFIDENTIAL

A new and exciting book covering the complete world of clandestine broadcasting yesterday and today — the first book published that covers all areas of this fascinating subject.

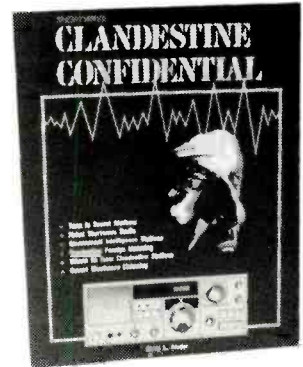

The contents of **CLANDESTINE CONFIDENTIAL** are: **ONLY \$8.95**

- I Clandestine DX'ing — DX'ing and identifying the clandestines.
- II Clandestines Yesterday — full history of the clandestines.
- III Clandestine Today — Listing 30 active countries with their frequencies and full story.
- IV Clandestines Tomorrow — where new clandestines may surface.
- V Clandestine QSLing — Verifying the clandestine stations.
- VI Clandestine station address list — up to date full address list of these many stations.

CLANDESTINE CONFIDENTIAL is exciting reading, covers all countries from Afghanistan to Zimbabwe. A must for the clandestine DX'er as the most up-to-date source of clandestine station address list.

CLANDESTINE CONFIDENTIAL retail price — only \$8.95 plus \$1.75 shipping and handling.

Universal Electronics, Inc., 4555 Groves Road, Suite 3  
Columbus, Ohio 43232 Phone: 614-866-4605

CIRCLE 114 ON READER SERVICE CARD

## DX ANTENNA TUNER KIT

(Similar to unit described in July issue)



All parts needed to build kit **\$14.95**

## VHF CONVERTER KIT

Receive any 4 Mhz segment between 60-230 Mhz



## TUNE IN AIRCRAFT, VHF HAMS AND PUBLIC SERVICE ON YOUR SHORT WAVE SET

Complete kit with instructions less crystal **\$25.95**

**BUILD RECEIVERS, TRANSMITTERS, TRANSCEIVERS,**

Add \$2 shipping and handling

Send For Hobby Kit Brochure

**MORNING DISTRIBUTING CO.**

P.O. Box 717 Hiialeah, Fla. 33011

CIRCLE 73 ON READER SERVICE CARD



# SCANNER SCENE

BY CHUCK GYSI, N2DUP

## MONITORING THE 30 TO 900 MHz "ACTION" BANDS

**S**ome of the more interesting communications on your scanner can't be heard across your city or town—you'll hear only what goes on in your neighborhood.

The Federal Communications Commission allocates certain frequencies for low-power use only. This means licensees are restricted to a maximum of 2 watts output power on these frequencies.

But who would use low-power channels? A hotel might use a low-power channel for security surveillance so officers don't tie up the hotel's primary frequency with an investigation; a railroad might use a low-power channel for yard operations; a telephone company might use low power to communicate with men working in an underground site; a construction company might use it to keep track of vehicles and foremen at a large construction site; municipal or state workers might use the frequencies on a highway repair job to facilitate the flow of traffic; a police department might use it for surveillance at a special event; and a fire department might use low power for fireground communications or to relay fireground communications over a primary frequency by using a mobile repeater. The possibilities are endless. However, a lot of assignments are grabbed up by large manufacturers and oil refineries that need to keep track of workers in a myriad of locations.

Several low-power channels have been around for a long time. These include:

Business: 30.84, 33.14, 33.40 (half-watt only), 35.02, 154.570, 154.600, 457.525, 457.550, 457.575, 457.600, 467.750, 467.775, 467.800, 467.825, 467.850, 467.875, 467.900, and 467.925.

Special Industrial (primarily farming and construction): 33.12.

Police and Local Government: 39.06.

However, a few years ago, the FCC recognized the fact that additional low-power channels were needed and dropped in 12.5 kHz splinter channels between other channels in the 451-470 MHz band. On the new low-power frequencies, power output still is limited to 2 watts, and even though all units are licensed as mobiles, they may perform as base or fixed (point-to-point) stations or as repeaters. In addition, any type of conventional emission is allowed, including Morse code, radioteletype, AM, sideband, or FM. Although some users may utilize these frequencies for data transmission, most communications probably will be FM voice because of the availability of equipment for such operation.

A station used as a base, fixed, or repeater station on the 12.5 kHz splinter channels may not employ an antenna more than 20 feet above the ground, or if at sea, no more

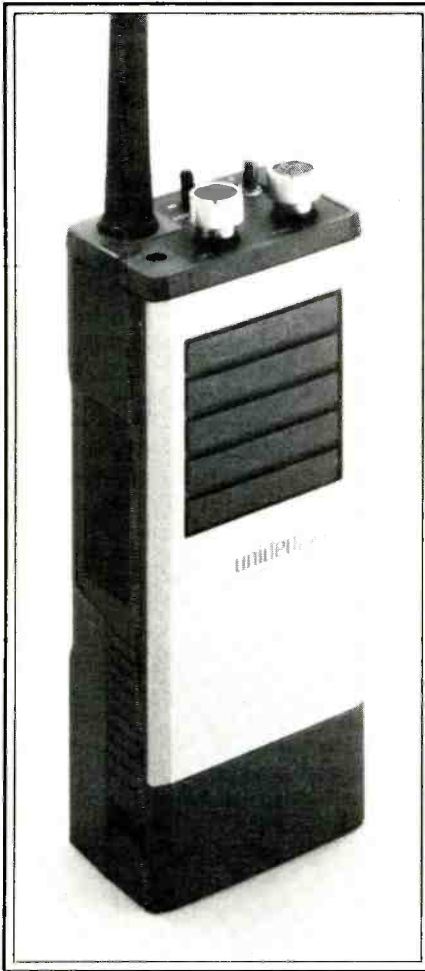

*Walkie-talkies are primarily used to communicate on the low-power channels because their output power is usually less than 2 watts.*

than 20 feet above a man-made support for the antenna. The height limitation is to ensure communications on the splinter channels does not interfere with routine communications on the normal adjacent channels. Also, the splinter channel assignments can be operated only over a small area; no wide area of operation is allowed. One advantage to some users is that the FCC does not impose any restrictions on the number of splinter channels that can be licensed to any one licensee. Thus, many large corporations that have a need for two-way radio, especially on a local, low-power range, have gobbled up literally dozens of these 12.5 kHz channels on their licenses.

Basically the way the FCC decides which splinter channels to assign to which service is based on the regular adjacent channels. Thus, because 461.8125 falls between the two normal business band assignments of

461.800 and 461.825 MHz, it is assigned for business band users. However, 457.9625 falls between 457.950, which is assigned for railroads, and 457.975, which is assigned to newspapers; thus the frequency is available for both users.

Although not all scanners are capable of scanning these splinter channels, if there is activity near your listening post, you will hear it quite adequately on the adjacent normal channel (in other words, you'll hear a splinter channel user on 461.6125 quite well on 461.600 or 461.625), as long as there is no activity on the regular channel. While the number of available regular channels becomes exhausted in many areas, expect a lot of users to switch over to these newer splinter channels.

The following list details users eligible to use each set of splinter channels. The pattern used after the frequency's decimal point is .X125, .X375, .X625, .X875, such as 461.3875, 461.4125, 461.4375, 461.4625, 461.4875, etc.

451.0375-451.1375—Power and water utilities.

451.1625—Forest products, petroleum industry, telephone companies, power and water utilities, manufacturers.

451.1875—Forest products, petroleum industry, telephone companies, and various manufacturers.

451.2125-451.2875—Forest products, petroleum industry, telephone companies, power and water utilities, manufacturers.

451.3125-451.3375—Several telephone companies.

451.3625-451.6875—Forest products, petroleum industry, telephone companies, power and water utilities, manufacturers.

451.7125-451.7625—Forest products, petroleum industry, construction, farming.

451.7875-452.0125—Construction and farming

452.0375-452.1875—Construction and farming, taxis.

452.2125-452.3125—Taxis.

452.3375-452.4875—Trucking firms, railroads, taxis.

452.5125—Tow trucks, taxis.

452.5375-452.5875—Tow trucks.

452.6125—Tow trucks, trucking firms.

452.6375-452.7375—Trucking firms.

452.7625-452.8875—Trucking firms, railroads.

452.9125-452.9375—Railroads.

452.9625—Newspapers, railroads.

452.9875—Newspapers.

453.0125—Local government, special emergency (hospitals, ambulance and dispatched rescue squads, veterinarians, school buses, doctors, disaster relief groups, beach patrols).

453.0375-453.7875—Fire departments, highway maintenance, local government, forestry conservation, police depts.  
 453.9125-453.9625—Fire departments, highway maintenance, local government, forestry conservation, police depts.  
 453.9875—Local government.  
 456.0375-456.1375—Power and water utilities.  
 456.1625-456.2875—Forest products, petroleum industry, telephone companies, power and water utilities, manufacturers.  
 456.3125-456.3375—Telephone companies.  
 456.3625-456.6875—Forest products, petroleum industry, telephone companies, power and water utilities, manufacturers.  
 456.7125-456.7625—Forest products, petroleum industry, farming and construction sites.  
 456.7875-457.0125—Farming and construction.  
 457.0375-457.1875—Farming and construction, taxis.  
 457.2125-457.2875—Taxis.  
 457.3125-457.4875—Trucking firms, railroads, taxis.  
 457.5125—Business, taxis.  
 457.5375-457.5875—Business.  
 457.6125—Business, trucking firms.  
 457.6375-457.7375—Trucking firms.  
 457.7625-457.8875—Trucking firms, railroads.  
 457.9125-457.9375—Railroads.  
 457.9625—Newspapers, railroads.  
 457.9875—Newspapers.

458.0125—Special emergency.  
 458.0375-458.1875—Fire departments, highway maintenance, local government, forestry conservation, police departments, special emergency.  
 458.2125-458.9625—Fire departments, highway maintenance, local government, forestry conservation, police departments.  
 458.9875—Local government.  
 460.0125-460.4625—Police depts.  
 460.4875-460.6375—Fire departments.  
 460.6625-460.6875—Business.  
 460.9125-461.2625—Business.  
 461.3875-461.8125—Business.  
 461.8625-462.1625—Business.  
 462.1875—Business, manufacturers.  
 462.2125-462.4375—Manufacturers.  
 462.4625-462.5125—Forest products, petroleum industry, telephone companies, power and water utilities, manufacturers.  
 462.7625-462.9125—Business.  
 462.9375-463.1875—Special emergency.  
 463.2125-464.9875—Business.  
 465.0125-465.4875—Police depts.  
 465.5125-465.5625—Fire departments, police departments, special emergency.  
 465.5875-465.6375—Fire departments.  
 465.6625-467.1625—Business.  
 467.1875—Business, manufacturers.  
 467.2125-467.4375—Manufacturers.  
 467.4625-467.5125—Forest products, petroleum industry, telephone companies, power and water utilities, manufacturers.  
 467.7625-467.9125—Business.

467.9375-468.1875—Special emergency.  
 468.2125-469.9625—Business.

### Update

Uniden Corp. of America has acquired the Bearcat line of scanner radios from Electra Corp. However, Masco Communications, which is an affiliate of Electra that has been making the Bearcat scanners, will continue to manufacture Bearcat scanners for Uniden.

The Bearcat acquisition is the largest for Uniden to date. The company also manufactures cordless phones, CB radios, marine electronics, and the Force line of VHF and UHF two-way radios.

### Talk To Us

We'd like to hear from you here at POP'COMM. Tell us about how you used your scanner on your summer vacation, or about how you are gearing up for some cold, winter monitoring. We'd like to know what your favorite frequencies are and will publish code and unit numbering lists. We also need photographs! Send along a photo of your base or mobile monitoring post, your antenna farm, or anything else communications related, such as a repeater site, a dispatch center, etc. We really do need your photographs! Send them along to: Chuck Gysi, N2DUP, Scanner Scene, Popular Communications, 76 North Broadway, Hicksville, New York 11801. **PC**

## The Nation's SWL/HAM Headquarters!

**ege, inc.**

13646 Jefferson Davis Highway  
 Woodbridge, Virginia 22191  
 Just 25 minutes south of Washington, D.C.

Wash., D.C. area 643-1063  
 In Virginia 800-572-4201

Store Hours: MWF 12 noon—8 p.m.; TThS 10 a.m.—4 p.m.



**R-2000**

**R-1000**

**R-600**

The R-2000 is an innovative all-mode SSB, CW, AM, FM receiver that covers 150 kHz - 30 MHz, with an optional VC-10 VHF converter unit to provide coverage of the 118-174 MHz frequency range.

### PANASONIC

Now in Stock  
 RF 2200, RF 3100, RF 799, RF 9  
 —Call for Introductory Prices—

### SONY

SWL Receivers in Stock  
 Models 2002, 4800, 6500, 7600A  
 —Call for a Good Deal—

**Interested in RTTY/CW  
 Reception with Your  
 Computer for Under \$100?**

Call Us About  
 the New MFJ RTTY/CW Reader

### REGENCY

Full line of Scanners  
 Handhelds, Mobiles, Base Stations  
 —Call for Our Low Prices—

### BOOKS, ANTENNAS & ACCESSORIES

—In Stock—



### ICOM R71

A Commercial-Grade Receiver  
 at a Not-So-Commercial Price  
 —Call for Your Best Price—



### BEARCAT DX1000

LISTEN TO AM/USB/LSB/CW/FM  
**BEARCAT SCANNERS IN STOCK**

Send 60¢ in Stamps for Catalog  
 Dealer Inquiries Invited

For Orders and Quotes—Call  
 CIRCLE 6 ON READER SERVICE CARD

**800-336-4799**

CIRCLE 6 ON READER SERVICE CARD



# DXing The "Top End"

## 1600 To 1800 kHz—It's Wild!



BY HARRY HELMS, KR2H

**T**alk about forgotten bands! If there ever was a DXing band that was "heard today and gone tomorrow," it has to be the 1600-1800 kHz range. It's known as the "top end" because it's found at the "top end" of the dial of a standard broadcast receiver. In the thirties, this range let listeners eavesdrop on police transmissions from all over the country at night. But when police departments departed for higher frequencies, and LORAN radio navigation moved, DXer interest in the top end dropped to almost zero.

But if you haven't tuned the top end lately, you're missing a treat. In this range you can find pirate broadcasters, rare lowpowered foreign broadcasters, beacons, wireless telephones, and some authentic mysteries. The LORAN stations that made listening in the top end so miserable are gone, and the DX is there for the grabbing!

### Legitimate Broadcasters

When most listeners think of broadcasters operating just above 1600 kHz, they think usually of pirates. However, there are several legitimate, licensed broadcasters operating above 1600 kHz—including some truly great DX!

One widely-heard station in eastern North America is The Caribbean Beacon on the island of Anguilla, a religious broadcaster often heard well until sign off around 0500 GMT. This station has been heard in California under good conditions. If you manage to hear it, you can send a report to Box 690, Anguilla, British West Indies. A young announcer at this station recently caused a stir in an American DX club when he wrote asking for donations to buy an FRG-7700 receiver—and if the money

wasn't forthcoming, he threatened to give up the DX hobby for good!

A rare catch—but one that has made it to California—is VL2UV, operated by University of New South Wales in Australia. It operates on 1694 kHz with 300 watts of power. It broadcasts University lectures and other educational programs. If you're located along the Pacific coast and have good receiving gear, try for it just before local sunrise. This station also has an outlet listed for 1750 kHz, but it has yet to be reported in North America.

Another rare Australian is 7RPH located in Tasmania. It operates on 1760 kHz with 500 watts and programming is "talking book" programming for the blind. So far it hasn't been reported in North America, but if you're located along the west coast try for it prior to its listed sign off at 1230.

Several other apparent broadcasters have been heard on the west coast and in Hawaii. Some of these are listed in our "Top End Frequency Guide" accompanying this article. Unfortunately, these stations are unlisted in standard references, so their location is unknown. If you're on the west coast, why not try for these and other mystery broadcasters?

### Pirate Broadcasters

For the past decade, the 1600-1650 kHz has been a favorite of unlicensed and unauthorized broadcasters. Most of these are concentrated in the northeast (primarily around New York City), yet can be heard at considerable distances—often over 1000 miles.

For the latest news on what's going on in pirate broadcasting, check out Pirates Den each month here in *POP'COMM*.

Pirate activity in the top end is most commonly found on weekend nights after 0500. One of the most widely heard stations is KPRC, 1616 kHz, which apparently operates from Brooklyn or Queens, New York. Its signal has been heard in Oklahoma, Michigan, and Illinois!

### Bacons

A scattering of radiolocation beacons are found in the top end. These are similar to those heard on longwave and repeat their calls in CW continuously. Perhaps the best heard is RAB at Rabinal, Guatemala. This beacon gets out remarkably well and has been heard throughout the United States and southern Canada. Similar beacons are listed in our guide to the top end.

However, many of the beacons you can find in the top end are somewhat mysterious. One of the most baffling is "FRB," a beacon which has been noted changing its operating frequency as much as 25 kHz in a single evening! No country or agency claims "FRB" and there is some question as to whether this is a legitimate radionavigation station or a cover for some other activity.

Other mystery beacons use calls beginning with the prefix "KA" followed by a series of numbers and letters. These beacons are believed to be part of geological seismic efforts taking place in such areas as the Gulf of Mexico or off the Florida coast. While such beacons are likely licensed to American companies or agencies, their exact locations have not been researched from FCC license files. These beacons tend to identify every five or fifteen minutes in CW with "cricket" or "bleep-bleep" sounds between identifications.

Similar beacons, but with calls not begin-

ning with "KA," are also heard in the top end. These beacons are believed to be operated by the Canadian government or by Canadian companies.

### Broadcast Support Stations

Recently, a Pennsylvania listener was puzzled to find broadcasts of Group W Satellite News on 1622 kHz. The frequency certainly would have been appropriate for a pirate, but an all news pirate?

It turns out that the listener intercepted a broadcast support transmission from Group W Satellite News in Washington, DC. Such stations operate so that remote news vans in the area can listen in on the broadcast audio and get their cues about when and what to broadcast. Most such stations use about 100 watts into a 5-foot monopole antenna. Frequencies for such activity are included in our list. If you manage to catch any, try sending reception reports to the station or organization whose audio is being rebroadcast.

### Experimental Stations

Have you heard KM2XNU on 1610 kHz lately? Did you even know there was such a station as KM2XNU? It's true! This station is

operated by Motorola, Inc., of Schaumburg, Illinois and is used for testing and evaluation of AM stereo receivers.

One of the more persistent rumors is that the FCC will propose expanding the broadcast band up to 1705 kHz. If this happens, you can expect more experimental stations to populate this range as well.

### Cordless Telephones

Eavesdropping on cordless telephone conversations has become a popular sport for many listeners. Among the most active frequencies reported have been 1690, 1710, 1740, 1750, 1760, and 1770 kHz. This is a prime time for this type of DX, since the FCC has recently allocated new channels near 49 MHz for cordless phones and future allocations will be at VHF/UHF frequencies.

### Travelers Information Service Stations

If you do much traveling, you've seen highway signs advising you to tune your AM radio for road, parking, detour, and similar information. Those are travelers informa-

tion service (TIS) stations, and 1610 kHz is a common frequency for them.

TIS stations are comparative pipsqueaks, running 10 watts or less into short antennas. However, they can sometimes be heard at surprising distances. For example, the TIS station at the Cincinnati airport has been heard in North Carolina! If you have a good antenna and a quiet location, why not spend time on 1610 and see what you can hear?

### Miscellaneous Activity

Some two-way traffic can be found in the upper range of the top end. Some of the stations which have recently been heard in North America are included in our list.

Several other unusual tones and sounds can also be found in the top end. Most of these receptions take place in regions along the Gulf of Mexico, and the odds are that many of these stations are operated by the military for various purposes.

As you can see, the top end is not a vast wasteland. Reception equipment and techniques are similar to those employed for the standard broadcast band. What are you waiting for? Start tuning up from 1600 kHz for some of the best DX around! **PC**

## "Top End" Frequency Guide

1606	Remote broadcast news cueing	1660	KUB (CW beacon), Kubuna, Papua New Guinea
1610	Traveler's Information Service (TIS)	1665	LAG (CW beacon), Lago Agrio, Ecuador
1613	RAB (CW beacon), Rabinal, Guatemala	1673	French traffic in SSB
1614.2	KA83309 (CW beacon), location unknown	1675	Continuous tone, no identification noted
1615	NZ (CW beacon), Nabzab, Papua New Guinea	1676	TSL (CW beacon), Tsili Tsili, Papua New Guinea
1615	OR (CW beacon), Ohura, New Zealand	1685	MER (CW beacon), Mercaderes, Colombia
1615	KA83310 (CW beacon), location unknown	1689	MH (CW beacon), Mt. Hagen, Papua, New Guinea
1618	KA83413 (CW beacon), location unknown	1690	KIU (CW beacon), Kiunga, Papua New Guinea
1618	KI341Y (CW beacon), location unknown	1690	MDE (CW beacon), Medellin, Colombia
1618	UDT (CW beacon), location unknown	1690	Chinese music and talk, probably Taiwan
1618.7	"Pip" every four seconds	1692	VL2UV, University of New South Wales, Australia
1619	FRB (CW beacon), location unknown	1694	FFB (SSB ship traffic), Boulogne Sur Mer, France
1619	RRP (CW beacon), location unknown	1700	Chinese talk and music; sign off at 1557
1619	SDT (CW beacon), location unknown	1700	ZM (CW beacon), location unknown
1621.2	UDT (CW beacon), location unknown	1705	KA83758 (CW beacon), location unknown
1622	Remote broadcast news cueing	1709.5	"QRL AS" repeated in CW
1622	KA83736 (CW beacon), location unknown	1710	KIU (CW beacon), Kiunga, Papua New Guinea
1628	KA83323 (CW beacon), location unknown	1714.5	IH (CW beacon), location unknown
1630	FZ953 (CW beacon), location unknown	1715	GLV (SSB ship traffic), Anglesy, United Kingdom
1630	Spanish traffic in SSB, location unknown	1716	NSS (CW beacon), location unknown
1634	KA83329 (CW beacon), location unknown	1722	French language traffic in SSB, probably for Europe
1634	KA83451 (CW beacon), location unknown	1729	D7K (CW beacon), location unknown
1636	FRB (CW beacon), location unknown	1732	Cordless telephones
1637	LZN (CW beacon), location unknown	1740	Cordless telephones
1637	KA80084 (CW beacon), location unknown	1740	NAH223K (CW beacon), location unknown
1637.6	D381 (CW beacon), location unknown	1744	PAT (CW beacon), location unknown
1638	FRB (CW beacon), location unknown	1750	Cordless telephones
1638	C225 (CW beacon), location unknown	1752	KC87 (CW beacon), location unknown
1640	KA83694 (CW beacon), location unknown	1754.5	"Pip" sound every two seconds
1641.5	0450 (CW beacon), location unknown	1755	Cordless telephone
1642	0384 (CW beacon), location unknown	1768	Unidentified RTTY station
1642	E369 (CW beacon), location unknown	1776	"Pip" sound every two seconds
1642	NV43 (CW beacon), location unknown	1780	Network of several weak CW stations
1642	V443 (CW beacon), location unknown	1785	SAG (SSB ship traffic), Goteborg, Sweden
1642	FXYC (CW beacon), location unknown	1792	Unidentified English traffic in SSB, British accent
1644	"LGB TLX" in CW followed by electronic tones	1801	ZL10 (CW beacon), location unknown
1646	Remote broadcast news cueing	1805	EV22 (CW beacon), location unknown
1648	M280 (CW beacon), location unknown	1848	UEU (CW beacon), location unknown
1649	KA81193 (CW beacon), location unknown	1850	SZT (CW beacon), location unknown
1651	J320 (CW beacon), location unknown	1850	JU37 (CW beacon), location unknown
1652	M313 (CW beacon), location unknown	1875	VG23 (CW beacon), location unknown



# LISTENING POST

BY GERRY L. DEXTER

## WHAT'S HAPPENING: INTERNATIONAL SHORTWAVE BROADCASTING BANDS

**T**ime for our monthly chat about shortwave broadcasting here in the Listening Post. We're glad to have you with us again, and, if it's your first time, we hope you'll join us regularly from now on.

If, like your editor, you were never fortunate enough to hear the Polish Pathfinder's station, the game is over. We've lost. The Polish Pathfinder's station, operated by the Polish Pathfinder's Union (a sort of Warsawian Boy Scouts), has been using shortwave since the late 1950's. The station was originally put on the air as an information and entertainment service for some three million Pathfinder members throughout Poland.

Originally, Pathfinder members operated the station mostly themselves with guidance from their instructors. In later years professional engineers and journalists joined the station on a part-time, freelance basis. Popular music has been a mainstay of the programming and more often than not the station was the first in Poland to introduce the latest music fads.

But, changing times and situations have spelled doom for the Pathfinders on shortwave. According to Dr. John Campbell who visited the station some months ago, reception of the broadcasts in Poland is deteriorating (and broadcasts were never intended for a foreign audience). There are fewer and fewer sets available in Poland that have shortwave bands and there's a fear that the old transmitter may fail and leave the station unable to continue its shortwave operations anyway. All of those factors combined in the decision to cease broadcasting on shortwave. Instead, the Pathfinders will produce a daily two hour program which will be aired on one of the state radio's FM networks.

At its end, the Polish Pathfinder's station operated on 6.195 with about one kilowatt of power from 0800 to 1400 on weekdays and 1000 to 1400 on the weekends. June 30 was the last day of broadcasting on shortwave. We are sad to see them leave the air and sadder still that we don't have a QSL card to show you!

On a somewhat brighter note we can report that the disappearance of Radio Belize from 3.285 was, thankfully, only temporary. Radio Belize was off the air from February until late May or early June; technical problems apparently. We are happy that this disappearance didn't turn out to be a permanent one.

Another station supposedly returning to shortwave is Radio Apinte in Surinam which, along with all of the other non-government stations in that country, was forced off the air some time ago in a crackdown on the media by Surinam's military government. The Radio Apinte transmitters were, in fact, used for the SRS government programming after the government's transmitters were bombed



Michael Masino provides us with a copy of Vatican Radio's attractive QSL card.



Jackie Cole in her Denver, Colorado shack.

by an anti-government group. That means that either the government now has a new transmitter for SRS (thus freeing Apinte's transmitter for shortwave use) or Apinte has re-started on medium wave only so far. We haven't been able to monitor Apinte on its return yet nor have we seen any recent reports of reception of this station. Check 4.995 or 5.005 during local evenings. Perhaps you'll spot it back on the air.

Radio Australia has moved some big new guns into position. The Carnarvon, Western Australia shortwave outlet which was destroyed in a cyclone some years ago is now rebuilt and a 300 kilowatt outlet just went on the air from this site. It's beamed at Asian targets.

The late 1980's are due to see new high power outlets go on the air from Radio Finland. The Pori transmitter site is being upgraded with three 500-kilowatt transmitters, one 250-kilowatt, and one 100-kilowatt unit, scheduled to be on the air by 1987.

Our friends at HCJB in Quito, Ecuador are adding still another transmitter to their immense complex. This is a 100 kilowatt unit that was donated to HCJB.

Speaking of HCJB, popular Clayton Howard aired his last DX Party Line program on June 18. Clayton's replacement is John Beck and we hope to introduce you to John in a future column.

It's switcheroo time in Columbia. La Voz de Guaviare in San Jose de Guaviare used that name when they were on medium wave only. They began shortwave use a couple of years ago and switched to Radio Transamazonia. Now they've gone back to the original name, so don't let it fool you if you tune them in and the name doesn't match the one that's listed.

Finally, there's some news about a possible expansion in shortwave broadcasting from Cameroon. A new outlet has been noted in Europe around 2100 on 7.290 which does not seem to be from Yaounde. It isn't clear yet whether the outlet may be coming from a city that hasn't yet had shortwave, although European monitors hear an unfamiliar local identification. Checks here have not found it at the usual 0430 sign on time for most Cameroon outlets.

### Mailbag

Let's look at the mail.

Mary K. Minard of Parma, Ohio checks in again (yes, we did get your first letter, Mary) to say that she listens to almost everything except the numbers stations, for which she can't find much enthusiasm. She is enthused about POP'COMM though and describes herself as "an incurable QSL collector." She uses a Yaesu FRG-7 and a longwire antenna. Mary is looking for a 1980 or later edition of the *World Radio TV Handbook* and also some plans for simple, limited space shortwave and broadcast band antennas. If you can help, drop Mary a line at 2119 Brookdale Avenue, Parma, Ohio 44134.

Mark Bills (P.O. Box 116, Mystic, Iowa 52574) wants to exchange correspondence and ideas with hams, SWLs, and 11-meter CB operators. His shack, pictured this



Iowa's Mark Bills at his well-equipped listening post.

month, includes a Heathkit HR10B receiver, Realistic DX-200 plus scanners and CB equipment.

Another listener who is also a ham operator is John E. Sullivan, KA0GCR, of Fenton, Missouri. He purchased a Kenwood R-1000 last summer and says it's a big improvement over the "garage sale" receiver he had been using. We'll look forward to receiving that shack photo, John.

The combination of a Drake SW4A and Allied SX-190 have produced good results for Ms. Jackie Cole of Denver, Colorado. She's logged over a hundred countries in the dozen years she's been listening.

John Stephens of New Hope, Alabama says that the Voice of Nigeria seems to be responding more quickly to reception reports since the coup there some months back. John wonders about the QSL policies of Mogadishu, Tirana, and Pyongyang as he has sent a number of reports without a reply. Pyongyang and Mogadishu tend to have spotty reputations, John, and all we can suggest is to keep after 'em. We understand that Radio Tirana likes reports covering entire programs or transmissions, so you might try that.

Still on the subject of QSLs, Pat McDonough of Pittsburgh, Pennsylvania observes that Radio France International seems to be taking longer to reply. We've noticed a problem here too, Pat. No response to reports on the new French Guiana relay station or, a reply comes in the form of a schedule and such, but no QSL.

David Don't-Use-My-Last-Name in Cleveland sends us a picture of his listening post and it should win some sort of "super shack" award. It's fully equipped with three scanners, the Kenwood R-2000 receiver, an Info-Tech M-600A for CW and RTTY reception and a long list of other items.

Regular reporter Robert Pastrick of Baden, Pennsylvania is the owner of a new Uniden CR-2021 receiver which is similar to the Realistic DX-400. Robert says he's very happy with the new unit.

Joe Wright in Boston notes that the Voice of Nicaragua and Radio Jamaharyiah both want return postage included with reception reports. We don't doubt that's true but we have to wonder why, since they are both government-run stations and both are obviously eager for letters from their listeners.

Early success in QSLing is reported by Bob Zirkelback of Pleasant Hill, California who's been collecting QSLs for only eight months and listening for about a year all together. He's using a Kenwood R-1000 and a 70-foot longwire antenna.

A new Kenwood R-600 sits in the shack of Gary Barnes in Four Oaks, North Carolina. Gary reports that he did get the owner's manual he was seeking, so we thank the good fellow or gal who came through and helped out Gary.

Navy radioman Greg Harris does his listening on board ship in the Far East using a Sony ICF-7600A and reports that he hears a lot of regional Chinese outlets thanks to his location.

# DON'T MISS OUT ON A SINGLE ISSUE OF



**Everyone interested in amateur radio needs his own copy of CQ. To read, to save, to refer to. Order your subscription now.**

*Fill out the coupon below. (Please print)*



The Radio Amateur's Journal  
76 North Broadway, Hicksville, NY 11801

**Please send me CQ for**  Life  3 Years  2 Years  1 Year  
**This is a**  Renewal  New Subscription Starting With \_\_\_\_\_ Issue.

**Rates (check one)**

	USA	VE/XE	Foreign
<input type="checkbox"/> 3 Years	<input type="checkbox"/> \$ 42	<input type="checkbox"/> \$ 48	<input type="checkbox"/> \$ 54
<input type="checkbox"/> 2 Years	<input type="checkbox"/> \$ 29	<input type="checkbox"/> \$ 33	<input type="checkbox"/> \$ 37
<input type="checkbox"/> 1 Year	<input type="checkbox"/> \$ 16	<input type="checkbox"/> \$ 18	<input type="checkbox"/> \$ 20

**Paid by:**  Check  Money Order  
 VISA  MasterCard

Account Number

--	--	--	--	--	--	--	--

Name \_\_\_\_\_

Street \_\_\_\_\_

City \_\_\_\_\_

State or Country \_\_\_\_\_

Zip \_\_\_\_\_



Ted Moran of Chicago has returned to the hobby after a time away, using an Allied SX-190 with a 70-foot random longwire. Ted likes to experiment with antennas and, due to his work schedule, finds himself listening at some odd hours.

Now—where's your letter? We're interested in hearing from you with your logging reports, questions, comments, shack photos, good quality high-contrast copies of QSLs, program schedules, press clippings, suggestions, and so on. You can write directly to POP'COMM at 76 North Broadway, Hicksville, New York 11801 and they'll forward your letter on to the Listening Post.

## Listening Reports

Here's what's on. All times are in GMT.

**Albania** Radio Tirana with a female announcer reading a story at 0137 to 0200 on 9.925. (Moran, IL) On 6.200 at 0330 with news and program on arts and literature, off at 0358 and QRM'd. (McDonough, PA)

**Argentina** RAE was noted on 15.345 at 0239 tune in with English, in parallel to 9.690. (Mayo, MA)

**Aescension Island** The BBC Atlantic Relay heard in Spanish with a discussion on the National Theater of Great Britain from 0140 tune on 9.765. Interference from Radio Moscow's North American Service. (Brumm, IL)

**Australia** Radio Australia on 15.395 at 0438 to 0500 in English and 15.160 at 0534 with "Australia Country Style." (Mayo, MA) 15.395 in English at 0509 with news, in parallel with 15.160. Good on the former, fair on the latter frequency. (Shute, FL) 11.720 at 0735 to 0745 with music. (Fravel, WV) 11.800 noted from 1200 to 1210 with news. (Fravel, WV)

Time station VNG heard with English ID on the hour on 7.500. (Moran, IL)

**Austria** ORF, Austrian Radio with interval signal and sign on in German at 0600 on 6.155. (Alpert, NY)

**Belgium** Brussels Calling from BRT, in English with interviews on 9.925 at 0030 to 0100. (Moran, IL) Good at 1430 to 1445 sign off on 17.610. (Mayo, MA)

**Brazil** Radio Bras, in English at 0233 on 15.290 with talk about a Brazilian author, Brazilian pop music. Good level. (Paszkiwicz, WI) English and pop music 0235 to 0251. (Moran, IL) English scheduled to Europe from 1750 to 1850 on 15.280, to North America from 0200 to 0300 on 15.290. (Mayo, MA)

Radio Cultura do Para in Belem noted on 5.045 at 0832 to 0900 in Portuguese with Brazilian music. (Fravel, WV)

**Canada** CBC in English on 6.195 with news followed by weather for Quebec. Into French at 0608 after identification for the Northern Quebec Service. BBC co-channel interference. (Alpert, NY)

**Chile** Radio Nacional, 15.140 in Spanish at 0103 with U.S. pops, Spanish vocals, identifications, time checks, advertisements, disco. Good strength. (Paszkiwicz, WI) From 2315 to 0020 with big band music to 0000, then early 50's rock. (Fravel, NY)

**Clandestine** La Voz del CID, 10.040 at 0125, somewhat distorted audio, all Spanish. (Sullivan, MO) 6.340 from 0613 with news in Spanish, utility interference and not heard since the one logging. (Alpert, NY) 10.040 is the new Radio Camilo Cienfuegos service. 6.340 was a test broadcast. (Editor)

**Colombia** Radio Nacional heard on 9.635 at 1148 with music and Spanish announcements. (Fravel, NY)

**Costa Rica** Radio Colombia, 4.825 noted at 0400 to 0430 in Spanish. (Hill, NY)

**Cuba** Radio Havana Cuba on 11.725 with sign on in English to the West Coast of North America at 0628. (Alpert, NY) At 0745 with English. (Fravel, WV)

**Czechoslovakia** Radio Prague, 7.345 at 0400 with news in an unidentified language. (Barnes, SC) Reception level varies widely from 0100 to 0200 during the North American transmission but the 0300 to 0400 segment seems more readable more often. (Landkamer, MN) At 0330 with commentary and easy listening music, good level. (McDonough, PA)

**East Germany** Radio Berlin International on 9.620 at 2205 to 2215 with news in English beamed to Africa. Interferes with Vatican Radio on 9.615. (Wright, MA) On

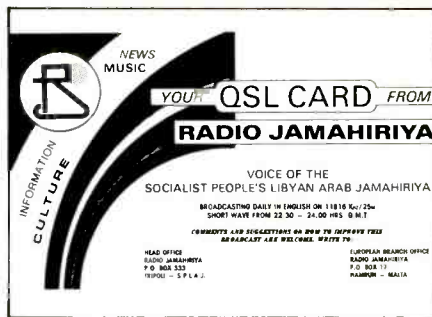

Radio Jamahiriya sent their well-designed card to Mary K. Minard.

9.600 at 2225 in English with the African service to 2255, into Spanish to the Caribbean at 2300. (Hill, NY) 11.920 heard in German at 0503, also on 9.620 at 2225 with English to Africa. (Shute, FL)

**Ecuador** Radio Quito in Quito heard on 4.920 at 0430 in Spanish. (Hill, NY)

Time station HD2IOA (Instituto Oceanografico de la Armada) heard with identification at 0559 on 3.810. (Moran, IL)

Radio Nacional, via HCJB facilities, on 15.350 at 2310 with news about Quito and Guayaquil, interference from an unidentified station. (Shute, FL)

HCJB in English to Australia and the Pacific from 0920 tune in on 6.130. "Back to the Bible" and "DX Party Line." (Pastrick, PA)

**England** BBC with English and book review at 2125 on 15.070. (Pastrick, PA)

**Finland** Radio Finland noted at 1401 on 17.800 with the "Northern Report" in English. (Fravel, WV)

**France** Radio France International at 0322 on 6.900 (?—Editor) with news in English and French, changing languages every 15 minutes. Light CW interference. (McDonough, PA) On 17.620 at 1336 with what sounded like a discussion in French concerning the Middle East. (Fravel, WV) On 7.135 at 0420 to 0430 with news and schedule information in English. (Moran, IL)

**French Guiana** RFO, Cayenne, at 0908 on 5.055 in French, seemed to be a discussion program, followed by music. (Fravel, WV)

**Ghana** Ghana Broadcasting Corporation heard at 0600 sign on at 4.915 with drum beat, identification, news and into vernaculars. (Stephens, AL)

**Greece** The Voice of Greece on 11.645 with news in English, good signal but the heavy accents of the announcers made it difficult to understand, from 0130 to 0140 then into Greek. (Wright, MA) On 9.865 at 0130 to

0145 with news and identification at 0146. On 11.645 at 0504 in Greek with flute and sheep bells interval signal. (Shute, FL)

**Guinea** Radiodiffusion Nacional, Conakry, 15.310 at 2345 to 0005 in French. (Fravel, WV)

**Haiti** 4VEH noted on 4.930 at 0000 with an English-French lesson. (Stephens, AL) At 2300 to 2300 with religious program in slow-speed English. (Hill, NY)

**Hungary** Radio Budapest heard on 9.835 from 0100 to 0130 and 0200 to 0230 in English. (Landkamer, MN)

**Indonesia** The Voice of Indonesia noted in Arabic on 11.790 at 1405 with talk by woman, singing, Koran, more talk, news. (Paszkiwicz, WI)

**Ireland** World Music Radio, via Radio Dublin, on 6.910 at 0306 in English with pop music, address, advertisement for the WRTH, mention of "Stereo 91." (Paszkiwicz, WI)

**Israel** Kol Israel heard at 0400 to 0415 in English on 15.585, then into French. (Mayo, MA) Strong in English from 0000 to 0024 on 9.440. (Moran, IL) 0005 to 0020 on 11.655 with commentary and very good signal. (Wright, MA) 21.675 from 1705 to 1712 in Hebrew. (Fravel, WV)

**Italy** RAI on 11.800 at 2230 with interval signal and into Italian. Interference from an unknown station on the same frequency. (Shute, FL) English scheduled daily at 0100-0120 on 9.575 and 11.800. (RAI via Mayo, MA)

**Japan** Radio Japan heard on 15.315 with interval signal, announcement in English and another language, off from 0447 to 0459, then open to just after 0500 when into music and English announcement about line trouble. (Mayo, MA) This was the relay from Africa Number One, Gabon. (Editor)

**Libya** Radio Jamahiriya, weak in 11.815 from 2300 to 0000. (Minard, OH) 11.816 in English at 2215 with news, American pop music, reggae, Green Book. (Paszkiwicz, WI) 15.450 now identifies as the "African service of Radio Jamahiriya," booming in with series recounting the story of the Libyan revolution at 1830 tune in. Later had pop music to 1922 sign off. (Alpert, NY)

**Lithuanian SSR** Radio Vilnius, via Radio Moscow facilities, on 11.720 at 2215 to 2230 sign off in English. (Hill, NY)

**Monaco** Trans World Radio, in English to Europe with Monte Carlo on 9.493. "Thoughts for the Day" program. (Pastrick, PA) 9.495 with 0658 sign on (after being on 7.160 from 0625 to 0658). Announces as "9.5 MegaHertz." (Alpert, NY)

**Netherlands** Radio Netherlands heard at 1450 on 17.605, weak, in English. (Mayo, MA)

**Netherlands Antilles** Trans World Radio from Bonaire noted in English to North America at 1158 on 11.815. World news to 1200, then "Through the Bible" broadcast. (Pastrick, PA)

**New Zealand** Radio New Zealand on 11.960 at



The "super shack" of Dave in Cleveland.



0500 with the domestic program relay, clear but rather weak. (Sullivan, MO) On 15.485 at 0510, weak with religious program in English. (Shute, FL) 11.960 to Australia and Pacific from 0825 tune in, with world news at 0830. (Pastrick, PA) At 0500 to 0600 but QRM'd by Canada after 0600. Also 15.485 from 0430 tune in with music from movies. (Mayo, MA)

**Nicaragua** Voice of Nicaragua, English news at 0400 and identification "You are listening to the news bulletin of the Voice of Nicaragua, a free voice in America." Full ID at 0430. Frequency announced as 6.015 although actually on 6.017.5. (Alpert, NY) English at 0100 and 0400. My frequency meter reads it as 6.017.546. English segments are one hour long. (Mayo, MA) 6.100 (before the switch to 6.017, Editor) at 0420 with announcers John and Betty. Seemed jammed after 0445. (Shiflet, CA) Strong at 0350. (Minard, OH)

**Niger** ORTN, Niamey, 5.020 at 1022 with religious program and music. (Fravel, WV) Odd to hear Africa on 60 meters at that hour. (Editor)

**Nigeria** The Voice of Nigeria on 15.120 at 0453 with a commentary and listener's letters. Poor level. (Mcdonough, PA)

**North Korea** Radio Pyongyang heard on 9.977 at 1100 to 1200 with English to North America. (Hill, NY)

**Norway** Radio Norway International with interval signal at 0500 on 11.870 and into Norwegian. (Shute, FL)

**Papua New Guinea** NBC Port Moresby on 4.890 at 1048 with music, followed by a newscast at 1100. (Fravel, WV)

**Portugal** Radio Portugal noted on 21.700 at 1713 in Portuguese, with music programs. (Fravel, WV)

**Saipan** KYOI with usual rock format on 9.665 from 1600 to 1715. Japanese announcements and frequent mentions of KYOI in Japanese. English identification at the top of the hour. (Stephens, AL) On 11.900 at 1208 in English and Japanese. (Pastrick, PA)

**South Africa** Radio RSA heard with letters from listeners at 0209 to 0240 on 9.615. (Moran, IL) On 9.585 at 1958 with an English identification and into France to Northwest Africa, Belgium, Switzerland, and France at 2000. (Hill, NY)

**Southwest Africa/Namibia** Southwest Africa Broadcasting Corporation heard at 0015 to 0048 on 3.270 with FM-type programming, much music, few announcements. Also on 3.295 from 0017 to 0030 in parallel. (Fravel, WV)

**South Korea** Radio Korea heard with sign on in English on 15.575 at 1400. Only 25% readable. (Mayo, MA)

**Spain** Radio Exterior Espana in English at 2006 on 11.690. (Mayo, MA) 9.530 at 2350 with music and news. Also on 17.650 at 1340 in Spanish. (Fravel, WV)

**Sri Lanka** Sri Lanka Broadcasting Corporation noted with their all-Asia service at 0200 on 15.425. "Sunday Morning Show" with birthday announcements, dedications, pop music. Fluttery signal but strength was building. (Stephens, AL)

**Sweden** Radio Sweden International, in English at 1405 on 15.190 with "Weekday Current Affairs" and promo for a show called "Shortwave Listening is Good For Your Health." (Barnes, NC) Heard with their new interval signal and identifications in several languages at 1500. Interference from France on the same frequency. 9.685 and 11.700 at 0230 to 0300 at something less than a strong level. (Landkamer, MN) 17.840 at 1602 to 1609 with news in English. (Fravel, WV)

**Switzerland** Swiss Radio International on 21.570 at 1200 with "Mailbag" in English. (Harris, Far East) On 17.760 at 1735 with good signal, news in German, clear identification as "Schweizer Radio International." (Wright, MA) On 9.885 at 0145 at excellent level. (Landkamer, MN) In Portuguese to Brazil at 2300 on 12.035. (Shute, FL)

**Tahiti** Radio Tahiti on 15.170 in Tahitian at 0341 with talk by two men and a woman in French, then Polynesian music. (Paszkiwicz, WI) At 0033 with rock, pop, identification in French, interference from an unidentified station on 15.165. (Shute, FL)

**Togo** Radiodiffusion Television Togolaise, signing on at 0530 in French on 5.047 with national anthem, religious music, news, and African music. Good strength. (Stephens, AL)

**Turkey** The Voice of Turkey heard with its interval signal and English identification, frequency announcements, and news at 2159 on 11.755. Interference from Moscow and the BBC on 11.750. (Shute, FL) English at 0300 to 0330 on 11.755. (Moran, IL)

**Uganda** Radio Uganda on 5.026 with news in English and into vernaculars at 0400. (Stephens, AL)

**Ukraine** SSR Radio Kiev, 11.720 from 0158 to 0230

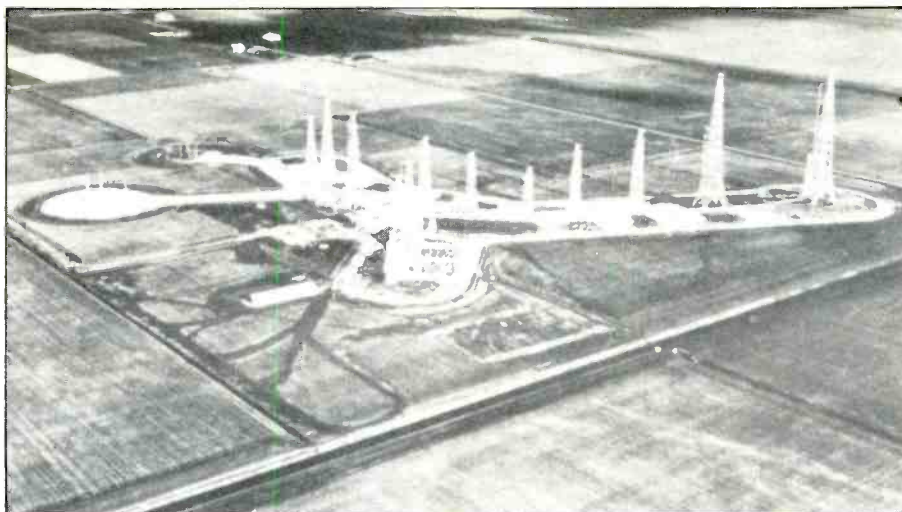

An aerial view of Radio Netherland's new high power Flevo transmitting station which should start testing by the end of the year.

with English and a strong signal. Mailbag at 0209. (Sullivan, MO) 17.860 at 0200 to 0230 in English. (Mayo, MA) Via Radio Moscow facilities. (Editor)

**United Arab Emirates** RCTV Dubai on 11.730 at 0329 to 0400 with English to North America. Also on 15.320 at 1600. (Mayo, MA)

**United States** Voice of America on 7.200 at 0333 with sports news. (Barnes, NC) At 2115 in English on 15.410 with item on Marcos and the Philippines. (Pastrick, PA)

AFRTS feeder on 9.242.5 in lower sideband at 0715 with news from the U.S. networks. (Alpert, NY)

WRNO in English on 11.965 with religious programs at 1633. (Pastrick, PA)

Radio Earth International, via WRNO, at 0340 to 0400 on 6.185. (Moran, IL) The broadcast will probably switch back to 0400-0500 when daylight time ends. (Editor)

WYFR in English beamed to Europe on 15.440 from 2100 tune in with religious programming. (Pastrick, PA)

**USSR** Radio Moscow on 15.135 at 1400 with news in English. (Barnes, NC) On 15.100 in English with a tribute to female jazz singers at 2045. (Pastrick, PA) 17.755 at 1351 to 1357 with music program in English. (Fravel, WV) 15.100 with United Kingdom Service at 1945. Into the World Service at 2000. (Alpert, NY) 9.700 at 0245 with talk on population problems in the U.S. as compared to the USSR. (Wright, MA)

Radio Moscow feeder in lower sideband on 16.193 at 0110 with North American Service. (Brumm, IL)

**Venezuela** Radio Maturin, 5.040 from 0350 tune in, identification and sign off at 0400. All Spanish. (Hill, NY)

YVTO, Observatorio Naval Cagical, Caracas, time station heard on 6.100 at 1000 in Spanish with identifications every minute. (Hill, NY) With ID at 0700. (Moran, NY)

**Vatican** Vatican Radio on 9.615 from 2210 to 2220 with talk on the Pope's trip. (Wright, MA) On 15.190 at 0507 to 0514 in English. (Mayo, MA) On 9.645 at 0500

in English to Asia and Oceania. Interval signal at 0519 and into an unknown language. (Alpert, NY)

**West Germany** Deutsche Welle to North America East Coast at 0100 to 0150 on 6.040, 6.085, 6.145, 9.545, 9.565, and 11.785; to the West Coast at 0500 to 0550 on 5.960, 6.120, 9.545, 9.690, and 11.705. (DW via Mayo, MA) 17.715 at 1346 with music, announcer in German. (Fravel, WV)

Radio Free Europe, in Romanian, at 0400 on 11.815, news and commentary. Good strength but flutter. (Stephens, AL)

**Yugoslavia** Radio Belgrad on 9.620 announcing themselves as "Radio Yugoslavia" at 2215. News, pop music to 2225. Interference from Canada on 9.625. (Stephens, AL)

That's the lot and these are the people you should thank: Larry R. Fravel, Clarksburg, WV; Michelle Shute, Pensacola, FL; Keith Hill, Pine City, NY; Michael Landkamer, Fairbault, MN; Mary K. Minard, Parma, OH; Gerald Brumm, Chicago, IL; John E. Sullivan, Fenton, MO; Joseph P. Wright, Boston, MA; Gary Barnes, Four Oaks, NC; Jeff Shiflet, Los Angeles, CA; Pat Mcdonough, Pittsburgh, PA; John Stephens, New Hope, AL; Robert Pastrick, Baden, PA; Sheryl Paszkiewicz, Manitowoc, WI; Ted Moran, Chicago, IL; RMI Greg Harris, USN; Stan Mayo, Portland, MA; and Dave Alpert, New York, NY.

See you next month. Until then, good listening!

PC

## WESTECH ELECTRONICS

### Authorized KENWOOD Sales and Service

R600—\$399.95 List  
R1000—\$499.95 List  
R2000—\$599.95 List

NEW!  
R-11 FM/AM/SW Portable  
Kenwood's Economical SW Receiver

Call for Your Special Price!!

ICOM R71A ←SAVE→ YAESU FRG7700

**RTTY** MFJ • AEA • KANTRONICS  
INTERFACES & SOFTWARE



Prices and availability subject to change, please call for latest information  
RTE 286, PRESQUE ISLE PLAZA, PITTSBURGH, PA 15239  
CALL (412) 733-1555 MT&W 10-6 Th&F 10-8 Sat 10-5



CIRCLE 144 ON READER SERVICE CARD





# Dig Those Army Birds

## The U.S. Army Satellite Communications Agency – What Do You Know About Them?

**A**pproaching its 10th birthday, the depot's Digital Communications Subsystem (DCSS) project is still going strong. And as it completes its first decade, the depot's single largest project is a complex effort that is expanding to include greater overhaul and modification requirements.

In 1974, the U.S. Army Satellite Communications Agency (SATCOMA) tasked the depot to build, stage, and field 58 DCSSs in fixed and mobile configurations to sites around the world. Since then, the requirement has grown to 100 sites, with 52 completed to date.

"The requirements for satellite communications are ever increasing," says John Adams, the project team leader from SATCOMA, an agency of the U.S. Army Communications-Electronics Command, Fort Monmouth, NJ. SATCOMA, the overall project manager, is responsible for the design, acquisition, support, and deployment of satellite ground equipment for all branches of the armed forces.

While the fielding of new DCSSs continues, depot personnel must also update the existing sites. "The project is ongoing, growing, and changing," says John Kort-



*Joseph Bianco checks out a UGC-74 teletypewriter installed in a Digital Communications Subsystem (DCSS). Bianco works in the Digital Communications Satellite Systems unit at Tobyhanna Army Depot. (U.S. Army photo)*

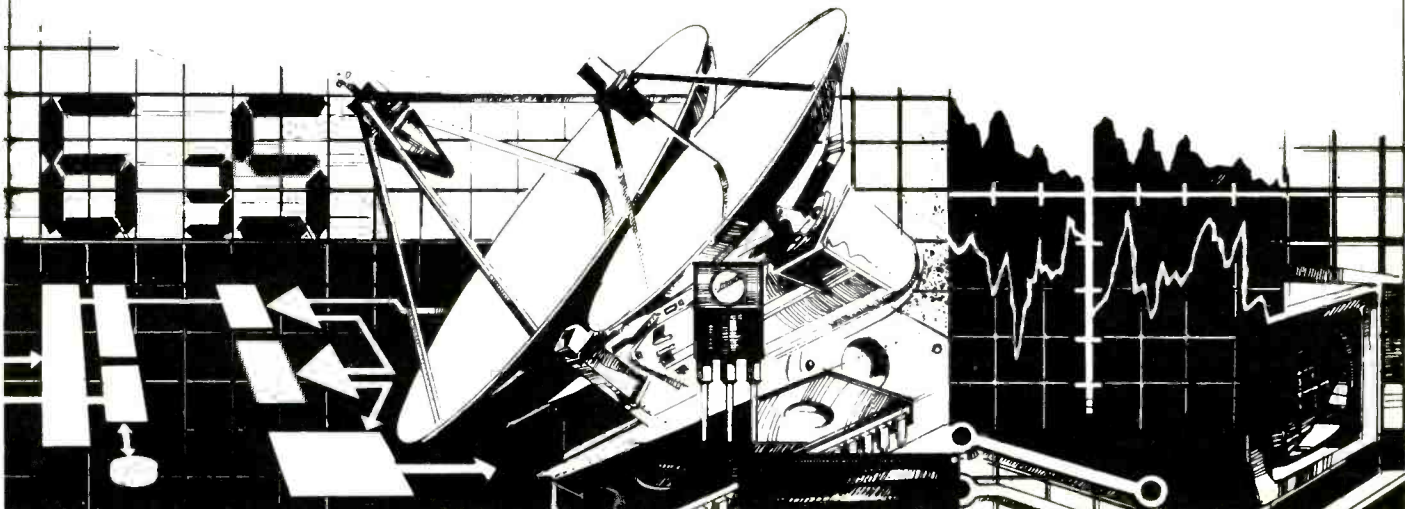

right of Stroudsburg, a foreman in the Digital Communications Satellite System Unit of the depot's Directorate for Maintenance.

Recently, personnel in the unit overhauled a DCSS van that was returned from Okinawa. "It was reworked, updated, and tested. We gave it a complete turnaround," says Jim Powell of Moscow, a technician in the unit. Following its overhaul, the DCSS was shipped overseas and put back in service.

A second van, fabricated and deployed from Tobyhanna in February 1979, recently returned from Augsburg, Germany. After rehabilitation and reconfiguration, it will be redeployed.

The original prototype van built here is in the process of returning from the Indian Ocean island of Diego Garcia. Upon its return, it will be used as an engineering test bed in support of new types of racks and equipment which are being designed to upgrade the existing worldwide communications facilities.

Currently, depot personnel are also staging a DCSS for a fixed site in Berlin. It will replace a mobile system there.

SATCOMA developed the DCSS for the Defense Satellite Communications System. It provides communications in a variety of forms, including high-speed computer data, teletype messages, facsimiles, and secure voice. It replaced an analog system that provided only basic voice transmissions.

Adams says the capabilities of satellite communications have increased dramatically. "The early systems of the 1960's only transmitted one voice and one teletype channel; now we transmit megabits of information on a global scale. There is a greater depth of technology today, the engineering requirements are more sophisticated. As an example, one ground station could now transmit all of the information in the Wilkes-Barre public library in less than 15 minutes."

Tobyhanna personnel build each DCSS to meet the specific need of its field user. This task is accomplished through the system's rack design. Each rack performs a certain function, says Kortright, such as multiplexing, modulation, coding, power, and system interface. By combining types and numbers of these racks, the needs of the field customer are satisfied. A DCSS may consist of as few as 25 racks or more than 100, depending on the type and volume of traffic at the site.

The racks also make it easier to upgrade the system as more sophisticated components are developed. This concept can be traced to the origin of the project. "It was known that more advanced systems were coming, so this allowed for changes," Kortright says.

Current modifications include the installation of the modern UGC-74 teletype and new electronic counter-countermeasures systems to prevent jamming of signals. "This is part of a worldwide improvement in tactical and strategic communications security," Adams explains.

Kortright notes that the quantity of modification work in his section recently surpassed

work on new fieldings. He expects that trend to continue.

"Generally, Tobyhanna is the support depot for overhauling satellite communications equipment," Adams says. "This role should increase. Tobyhanna has earned recognition at very high levels of the Army for its satellite work."

Since its inception, the DCSS project has involved personnel in nearly every depot organization. The size of the program also prompted the creation of the SATCOM/Data Systems Section, made up of personnel drawn from the depot's former Avionics and Radio shops.

SATCOMA also has established an engineering field office here to oversee the project. It is staffed by two civilian and two military personnel.

The close working relationship between the Satellite Communications Agency and Tobyhanna has accomplished the fabrication, fielding, and support of these vital links in the defense communications network. With a growing workload, that relationship is expected to continue for many years. **PC**

**FANTASTIC SPACE-AGE  
ELECTRONICS**

**LASER WEAPONS, INVISIBLE  
PAIN-FIELD GENERATORS, MORE...**

Survival writer discovers... secret sources for laser pistols, listening devices, ultrasonic pain field generators, paralyzing self-defense protectors, true I.R. see-in-the-dark viewers, absolute security systems, bug detectors, voice scramblers, micro-transmitters, electronic tracking devices, ultra-sophisticated detection and surveillance equipment, police broadcast unscramblers, many more too "hot" to print. Send \$1.00 for giant catalogue (get \$2.00 credit) To:  
**UNIVERSAL SECURITY, Dept. PC-10,**  
15015 Ventura Blvd., Ste #1653, Sherman Oaks, CA 91403

CIRCLE 39 ON READER SERVICE CARD

**"THE ROCK OF NEW ORLEANS"  
BECOMES  
"THE ROCK OF THE WORLD"**

**WRNO**

**THE ROCK OF NEW ORLEANS  
FM 99**

**WRNO/WORLD WIDE  
ROCK N' ROLL ON YOUR RADIO**  
Now Playing in the 49, 25 & 19 Meter Band!  
WRNO WORLDWIDE NEW ORLEANS LA USA

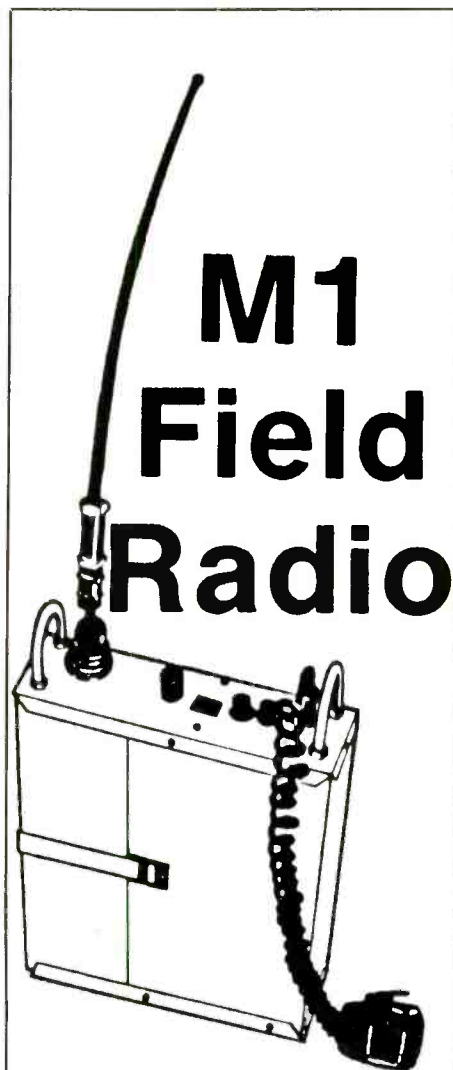

**Combining the best of Citizen's Band and military combat radios. Now rugged, portable communication is available to everyone.**

The M1 Radio is made for hard service. It is strongly cased in box-sectioned aluminum, silicone sealed against water and dust, and the radio chassis is antishock-packed in instrument foam. The flexible, synthetic antenna is virtually unbreakable. Requires only common "D" cell batteries.

**\$289** Radio with mike, headset, and instruction manual

Carry Pack available for \$14.95

Send me a complete catalog.

**THE BUNKER**

(205) 491-4487  
723A Brooklane Drive  
Hueytown, Alabama 35023

CIRCLE 143 ON READER SERVICE CARD



## NEW AND EXCITING TELEPHONE TECHNOLOGY

### High Seas Telephone Calls

An elaborate system of shore stations provide telephone service to mariners plying the high seas. Both the pleasure boat enthusiast as well as the commercial work boat make good use of the high seas radiotelephone system.

This worldwide marine radiotelephone service operates on specific channels in the high frequency spectrum using upper side-band. This makes it easy for you to tune into these phone calls with an inexpensive shortwave receiver that may tune in upper side-band signals. (Shortwave sets with only AM will not be able to clarify the signals.)

The FCC centers the radiotelephone channels around the following frequencies:

- 4 MHz For 500-mile contacts
- 6 MHz Used primarily on the Mississippi
- 8 MHz For 2,000-mile contacts

- 12 MHz Worldwide calls, day or night
- 16 MHz Worldwide calls, day and evening
- 22 MHz Worldwide calls, days

American Telephone & Telegraph (AT&T) operate three major shore stations that provide mariners with telephone service. There are also smaller companies that provide more local telephone service on the 2 MHz, 4 MHz, and 6 MHz bands.

The three AT&T stations can easily provide mariners with worldwide telephone coverage no matter where they cruise. A listing of the frequencies that each AT&T station operates on are shown in Table 1, Table 2, and Table 3.

As you can see by these frequency charts, the ship stations transmit on frequencies below the shore station. Shore stations transmit

on frequencies approximately 600 kHz above the ship stations, and to hear both sides of the conversation, you will need to enter both frequencies into your shortwave receiver. You will manually switch back and forth between the ship and shore station as the telephone call is taking place.

You should be able to tune in the shore stations without any difficulty. Each shore station uses up to 1,000 watts of power into high gain rhombic antennas that beam the signals out to the ocean. The shore station technical operators will switch rhombics to insure that they have chosen the one that best transmits and receives to the ship station. Rhombic antennas provide tremendous amounts of forward gain and allow the shore station to be heard easily by the ship station, and further allow the shore station to

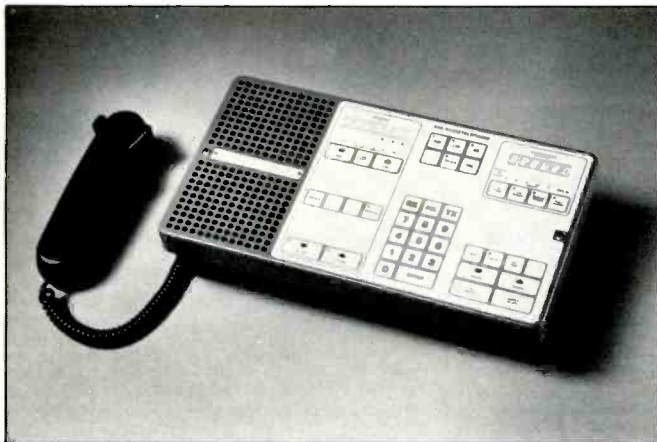

Ship marine SSB radiotelephone.

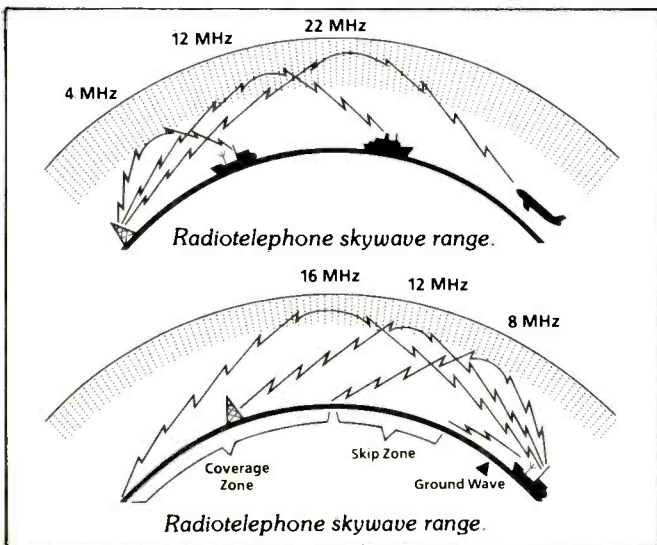

#### Coast Station KMI — California

Address: AT&T  
Station KMI  
P.O. Box 8  
Inverness, California 94937

For technical information call: (415) 669-1055

Coast Station	Channel Designation	Coast Station Transmit (Carrier)	Ship Station Transmit (Carrier)
<b>KMI</b> Point Reyes Calif.	417	4407.0	4112.6
	416	4403.9	4109.5
	401	4357.4	4063.0
	822	8784.0	8260.1
	809	8743.7	8219.8
	804	8728.2	8204.3
	1229	13,187.6	12,416.8
	1203	13,107.0	12,336.2
	1202	13,103.9	12,333.1
	1201	13,100.8	12,330.0
	1624	17,304.2	16,531.3
	1603	17,239.1	16,466.2
	1602	17,236.0	16,463.1
	2236	22,704.5	22,108.5
	2228	22,679.7	22,083.7
2223	22,664.2	22,068.2	
2214	22,636.3	22,040.3	

Channels: 401, 804, 822, 1201, 1229 and 1602

Channels: 416, 809, 1202, 1203, 1603 and 2214

GMT	TRFC	WEATHER	GMT	TRFC	WEATHER
0000	X	◇	0100	X	
0300	X		0400	X	
0600	X	◇	0700	X	
0900	X		1000	X	
1200	X		1300	X	◇
1500	X	◇	1600	X	
1800	X		1900	X	◇
2100	X		2200	X	

◇ Broadcasts of National Weather Service Information.  
Traffic Lists and Weather will be omitted on any busy channel.

Table 1.

## Coast Station WOM — Florida

Address: AT&T  
 Station WOM  
 1350 N.W. 40th Avenue  
 Fort Lauderdale, Fla. 33313

For technical information call: (305) 587-0910

Coast Station	Channel Designation	Coast Station Transmit (Carrier)	Ship Station Transmit (Carrier)
<b>WOM</b> Ft. Lauderdale, Fla.	423	4425.6	4131.2
	417	4407.0	4112.6
	412	4391.5	4097.1
	403	4363.6	4069.2
	825	8793.3	8269.4
	810	8746.8	8222.9
	805	8731.3	8207.4
	802	8722.0	8198.1
	814	8759.2	8235.3
	831	8811.9	8288.0
	1215	13,144.2	12,373.4
	1209	13,125.6	12,354.8
	1208	13,122.5	12,351.7
	1206	13,116.3	12,345.5
	1223	13,169.0	12,398.2
	1230	13,190.7	12,419.9
	1616	17,279.4	16,506.5
	1611	17,263.9	16,491.0
	1610	17,260.8	16,487.9
	1609	17,257.7	16,484.8
	1601	17,232.9	16,460.0
	2222	22,661.1	22,065.1
2216	22,642.5	22,046.5	
2215	22,639.4	22,043.4	

Channels: 403, 802, 1206, 1601 and 2215

GMT	TRFC	WEATHER	GMT	TRFC	WEATHER
0030	X		0130	X	
0430	X		0530	X	
0830	X		0930	X	
1230	X	◇	1330	X	◇
1630	X		1730	X	
2030	X		2130	X	

Channels: 417, 810, 1209 and 1610

GMT	TRFC	WEATHER	GMT	TRFC	WEATHER
0230	X		0330	X	
0630	X		0730	X	
1030	X		1130	X	
1430	X		1530	X	
1830	X		1930	X	
2230	X	◇	2330	X	◇

◇ Broadcasts of National Weather Service Information  
 Traffic Lists and Weather will be omitted on any busy channel

Table 2.

## Coast Station WOO — New Jersey

Address: AT&T  
 Station WOO  
 P.O. Box 558, Beach Avenue  
 Manahawkin, N.J. 08050

For technical information call: (609) 597-2201

Coast Station	Channel Designation	Coast Station Transmit (Carrier)	Ship Station Transmit (Carrier)
<b>WOO</b> Manahawkin, New Jersey	422	4422.5	4128.1
	416	4403.9	4109.5
	411	4388.4	4094.0
	410	4385.3	4090.9
	826	8796.4	8272.5
	815	8762.3	8238.4
	811	8749.9	8226.0
	808	8740.6	8216.7
	1228	13,184.5	12,413.7
	1211	13,131.8	12,361.0
	1210	13,128.7	12,357.9
	1203	13,107.0	12,336.2
	1631	17,325.9	16,553.0
	1626	17,310.4	16,537.5
	1620	17,291.8	16,518.9
	1605	17,245.3	16,472.4
	2210	22,623.9	22,027.9
	2205	22,608.4	22,012.4
	2201	22,596.0	22,000.0
	2236	22,704.5	22,108.5

Channels: 410, 826, 1210, 1631 and 2205

Channels: 411, 815, 1211, 1605 and 2210

GMT	TRFC	WEATHER	GMT	TRFC	WEATHER
0000	X		0100	X	
0400	X		0500	X	
0800	X		0900	X	
1200	X	◇	1300	X	◇
1600	X		1700	X	
2000	X	◇	2100	X	◇

Channels: 416, 808, 1228, 1620 and 2201

Channels: 422, 811, 1203, 1626 and 2236

GMT	TRFC	WEATHER	GMT	TRFC	WEATHER
0200	X		0300	X	
0600	X		0700	X	
1000	X		1100	X	
1400	X	◇	1500	X	◇
1800	X		1900	X	
2200	X	◇	2300	X	◇

◇ Broadcasts of National Weather Service Information  
 Traffic Lists and Weather will be omitted on any busy channel

Table 3.

tune in weak ship stations so they sound loud and clear. The rhombic antenna system at each shore station encompasses several hundred acres of land—on some frequencies, the rhombic antenna is over a half-mile long!

The shore stations will also transmit "traffic lists" to ships at sea. Every three hours they will broadcast the names and callsigns of vessels that have someone calling them from shore. When a vessel hears its boat name and call letters, it simply announces itself on frequency and the technical operator will then patch through the phone call. If you are only tuning into the shore station, you will just hear the shore party only. You will need to switch to your other VFO to tune in the ship station.

High seas weather broadcasts are also transmitted by shore stations approximately every six hours. If you want to find out the very latest weather conditions out on the

Calling home on the high seas.

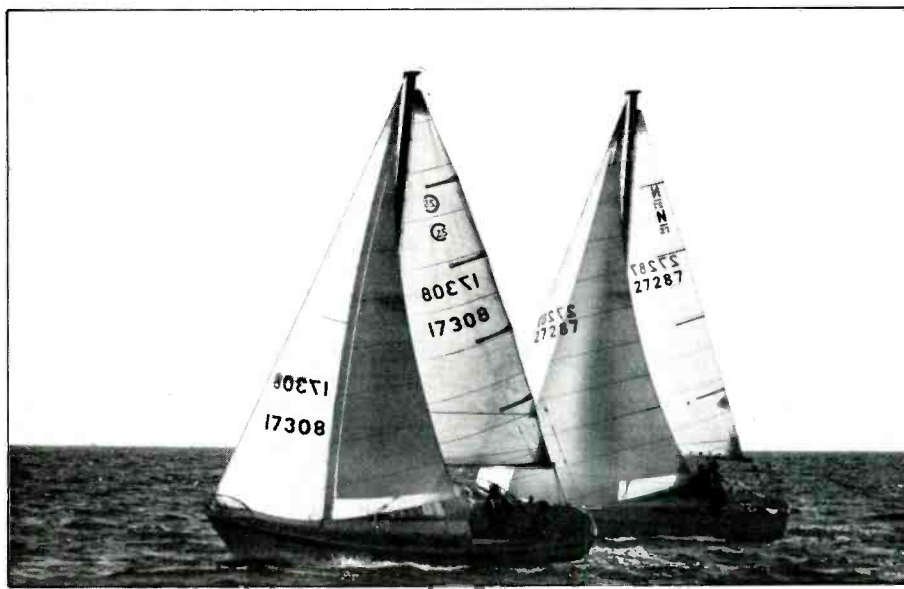



# Delaware Amateur Supply

71 Meadow Road, New Castle, Del. 19720  
Factory Authorized Dealer! 302-328-7728  
9-5 Daily, 9-8 Friday, 9-3 Saturday

**KENWOOD, ICOM,  
YAESU, MICROLOG,  
KANTRONICS, AEA**

**Order & Pricing**

**800-441-7008**

NO Sales Tax in Delaware! one mile off I-95

Please send all reader inquiries directly.

## FCC LOWERS REQUIREMENTS GET YOUR RADIO TELEPHONE LICENSE

FCC changes make obtaining High-Level Radio Telephone License much easier now. Eliminate unnecessary study, with our short cuts and easy to follow study material. Obtaining the General Radio Telephone License can be a snap! Sample exams also section covering Radar Endorsement. A small investment for a high-paying career in electronics. \$19.95 ppa. Spi-Ro Distributors, P.O. Box 1538, Dept. PC, Hendersonville, N.C. 28793.

CIRCLE 72 ON READER SERVICE CARD

high seas, the weather broadcasts are just the answer. The KMI station in California transmits Pacific weather. The WOO station in New York transmits the North Atlantic weather. The WOM station in Florida transmits the Caribbean weather. The weather broadcasts start right on time, so it's a good way to doublecheck which MegaHertz band is coming in best for your particular area.

The high seas radiotelephone service also may be linked directly to the United States Coast Guard in case of a high seas emergency. Many times you will hear some exciting traffic between hospitals, the military, and the United States Coast Guard to ships at sea. It's even more exciting if you can tune in the other side of the conversation by switching to the ship transmit channel.

Boat owners who wish to take advantage of the worldwide communications system must first have a valid FCC marine radiotelephone license. This requires no test—only the transmitting equipment. All transmitting equipment must be FCC Part 83 type accepted. Most equipment runs 100 watts output, and transmits upper sideband only.

After the equipment has been installed, ship stations will then apply for a marine identification number—similar to a land lubber's telephone credit card. This "MIN" number is given to the operator each time a phone call is placed.

Phone calls are relatively expensive, too. A typical 3-minute phone call might run as much as \$15 or \$20, depending on long distance rates. The minimum amount of any

phone call will be \$15, so you won't hear long-winded conversations!

Someone wishing to call a ship out on the high seas needs only to dial 1-800-SEA-CALL. This will allow the calling party to reach the high seas marine operator. The operator will then take down the vessel name and call letters, if known. The operator will then attempt to contact the vessel out on the high seas and will return a phone call to the calling party indicating that the link-up has been made.

Every now and then you may hear some bizarre telephone calls. You might tune into an ice breaker slowly approaching the South Pole. Or maybe you'll hear a fisherman in the mid-Atlantic finding out that he is now the proud father of twins. You might also tune in on a call from a super-tanker to a local hospital and the Coast Guard for an evacuation of a sick or injured passenger.

What you hear over the high seas radiotelephone system is strictly confidential—you are not allowed to divulge the contents of any received message.

The AT&T worldwide high seas radiotelephone system is one of the finest in the world. If you would like to receive a huge wall chart showing their worldwide antenna coverage for stations KMI, WOO, and WOM, write AT&T, Manager—High Seas Services, 201 Littleton Road, Room 220, Morris Plains, New Jersey 07950, "Transmitting Antennas High Seas Radiotelephone Service Charts, KMI, WOO, and WOM." **PC**

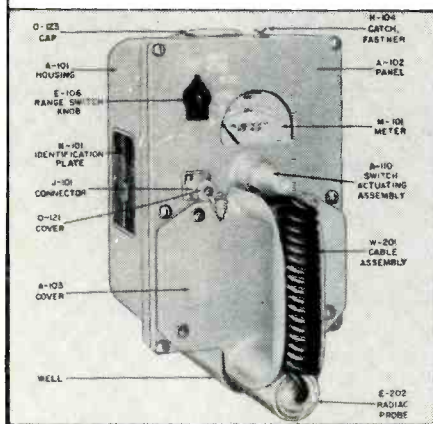

## John J. Meshna Jr., Inc.

19 Allerton Street • Lynn, MA 01904 • Tel: (617) 595-2275

### R-390A/URR RECEIVER

World-famous R-390A military receivers are again available to the surplus market. These receivers cover the range of 0.5-32 MHz in AM, CW, MCW modes over thirty-one 1 MHz bands which read out directly on digital mechanical counters, 455 kHz final IF. The radio has 4 Collins mechanical filters allowing 2-4-8-16 kHz selectable bandwidths. There are calibration points every 100 kHz, also BFO, AGC, dial locks, 600 ohm audio output. The radios are complete less meters and covers (made for rack mount). They are checked for completeness prior to shipping. Sold as is. We can ship in two boxes via UPS. Shipping weight is 85 lbs.

**R-390A \$225.00**

**Copy of technical manual for this radio \$15.00**

### PDR-27 NAVY RADIATION METER

Just released by the US Navy. They appear to be in excellent condition and include the fitted aluminum transit case. Batteries not furnished but are available in most electronic supply houses. 4 ranges 0.5 to 500 mr/hr. Removeable hand probe, detection of Beta and Gamma radiation. With today's world conditions and perhaps proximity to a nuke power station, it might provide a little insurance to own one of these instruments. With no facilities to check or test, we offer AS IS, visually OK Schematic provided with each. We have some accessories and offer as an option although not required for operation.

Shipping wgt. 22 lb. PDR-27 Rad Meter \$50.00

PDR-27 phones \$7.00

Hi Sensitivity GM tube \$10.00

Approx. 100 page Instr. Book \$10.00

Low Sensitivity GM tube \$5.00

The above listed tubes are already installed in the meter.

We are offering these as spares if desired.

**PHONE ORDERS accepted on MC, VISA, or AMEX No COD's. Shpg. extra on above. Send for free 72 page catalogue jam packed w/bargains.**

CIRCLE 24 ON READER SERVICE CARD



# “DAH-DI-DAH”

## Just What Does CW Really Mean?

BY W. CLEM SMALL, KR6A

**A**lmost any person involved in radio, be they monitoring buff, experimenter, amateur, technician, or engineer, can tell you that “CW” means “continuous wave.” It’s true that some may tell you that it also means “clockwise” or even “country western.” And, no, it doesn’t stand for “coded words,” although that seems like a reasonable guess since CW is the common means of sending Morse code by radio. Just what do those initials “CW” mean? Well, they represent one of those anachronisms left over from the era when “King Spark” and the Poulsen Arc ruled the air, or rather “aether” as it was called in those days.

So the truth is, then, that the term “CW” has come down from that long and fascinating past which started with Heinrich Hertz when he demonstrated the validity of James C. Maxwell’s now famous theoretical predictions for electromagnetic radiation. Hertz demonstrated that electromagnetic signals could be radiated into space (“radio”) by means of a spark-gap transmitter and received without connecting wires (“wireless”) by a spark-gap receiver similar to that shown in Figure 1. A spark jumping the gap at B in Figure 1 would be accompanied by a very faint spark across the gap at C if the ring were not too distant (a few feet) in space from the transmitter.

As you probably know, Marconi extended Hertz’s work to a practical communications reality and, just after the turn of the century, spark transmitters were amazing the world with their ability to provide communications across even the vast reaches of the very oceans themselves. These transmitters were essentially the same as Hertz’s early transmitter, with variations in the antenna system used. Hertz, in some instances, used only the rods holding the spark-gap balls (B in Figure 1) as his antenna system. Marconi, on the other hand, connected one side of the spark-gap to a large external antenna and connected the other side of the spark-gap to the earth (ground). Using such an antenna-ground system and an improved detector (the coherer), Marconi was able to demonstrate the potential of long distance radio communications. All of these feats were accomplished using radio waves known as “damped waves.” They were called “damped” due to the nature or characteristic form of the wave produced by the spark transmitters used. As a spark occurred at the gap of a spark-gap transmitter, it produced a signal rich in radio frequency waves.

A modern day analog of these broadband signals exists in the form of radio frequency interference from automobile spark plugs and ignition coils. The spark plug is an-

other form of a spark-gap and the ignition coil is another variety of induction coil. They produce a lot of radio frequency as you will see if you hold an AM portable radio near the ignition system of an operating automobile engine. In spark-gap transmitters, the spark-gap current was used to excite the antenna-ground system and thus to provide the radio signals on which the old-time radio operators depended for their radio communication. But this still doesn’t tell us why we call those waves “damped waves” and what that has to do with the term CW. Read on!

Spark-gap transmitters utilized a vibrating switch or buzzer to turn their induction coil on- and- off at an audio-frequency rate. Two things happened as this switch operated: one was the production of radio-frequency waves as the high voltage from the induction coil jumped the spark-gap; the other thing that happened was that the audio rate of the buzzer was imposed or modulated onto the radio-frequency signal as it was created at the gap. Each dit or dah of the Morse code that was sent caused an audio-frequency note in the headphones of the operator listening to that signal. Within each audio-frequency dit or dah, the audio note was actually caused by a series of pulses of radio-frequency, one pulse produced for each spark at the gap. In other words, if the audio note that the operator heard was 1000 Hz, this would be due to the spark-gap producing 1,000 pulses of radio-frequency energy per second.

Figure 2 is a representation of how four of these radio-frequency pulses might look if viewed with an oscilloscope. Note that each pulse contains several cycles of radio-frequency energy. Each pulse begins with a strong amplitude which quickly fades away to zero amplitude. This decaying away of the signal within the pulse is called “damping.” Damping is familiar to us in other situations such as the plucking of a musical instrument string. When the string is first plucked, it vibrates with a strong amplitude which quickly fades away to zero amplitude as the sound of the string fades. The fading away of the sound from the string of the musical instrument is due to a loss of energy in the vibrating string as it uses that energy to produce sound waves in air. This loss of energy “damps” the waves. A comparable thing happens to the waves in the spark-gap transmitters antenna system: the spark-produced waves lose energy, primarily by radiating it into space as radio waves. The waves thus become damped or decreased in amplitude due to this loss. The name given to radio-frequency waves produced by a spark transmitter then is “damped waves.” So, what does this have to do with CW? Let’s continue with our radio history and see.

In the first two decades of this century, transmitters other than the spark-gap transmitter were developed and put to use. They were: the arc transmitter, the alternator, and the vacuum tube transmitter. All of these newer types of transmitters produced signals which resemble those shown in Figure 3. That is, all of these newer types of transmit-



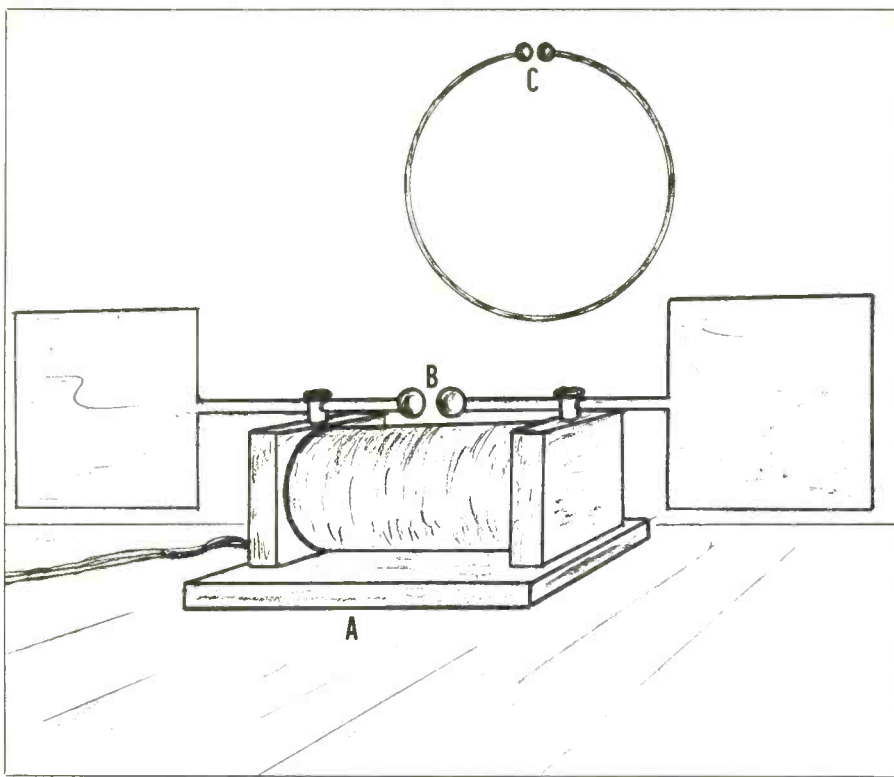

**Figure 1:** Spark-gap transmitter and receiver similar to those used by Heinrich Hertz to demonstrate the existence of radio waves in the late 1800's. The system used an induction coil (A) with a spark-gap (B) and a ring receiver with a very small spark-gap at C.

ters produced signals which maintained a constant peak amplitude in the wave across the time during which the wave existed. Such waves are called "undamped" and are said to be continuous in their amplitude value. They are thus called "continuous waves" or CW." The spark-gap transmitter produced damped-waves, but its successors produced undamped CW.

Well there you have it. CW doesn't stand for "coded words" after all! The crackling blue flame of the spark-gap transmitter with its damped waves produced quite a different sounding signal from that of the silent steady yellow arc with its continuous waves. By the time continuous wave transmitters became

practical for the field of wireless operating, the term CW was already in use in the infant field of wireless engineering. Quite naturally enough, the old time operators picked the term up from the engineers (Marconi himself used the term) and began to use that term to describe their new signals. It matters not that some other signals are technically also continuous wave signals. CW is a term we now reserve exclusively for Morse code radio signals. And today, for all of our hi-technology, long after the spark transmitter has forever stilled its raspy voice, we retain a bit of nostalgia from radio's golden years when we describe Morse code radio communication as CW.

PC

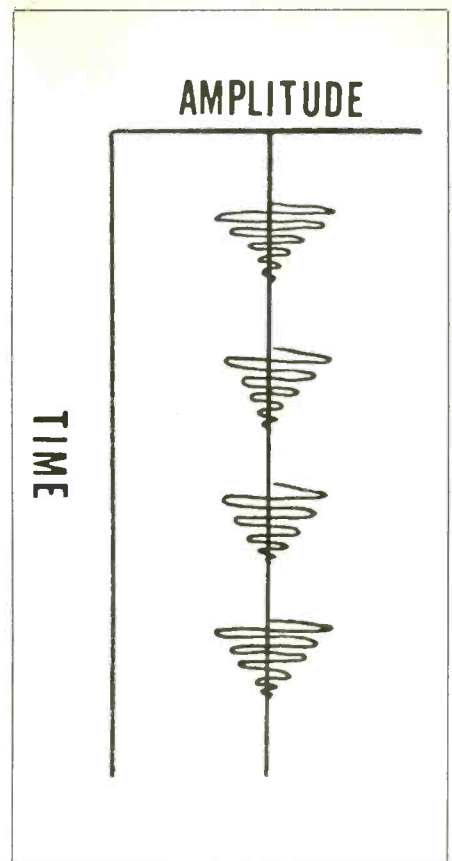

**Figure 2:** Radio-frequency current in the antenna system of a spark-gap transmitting station.

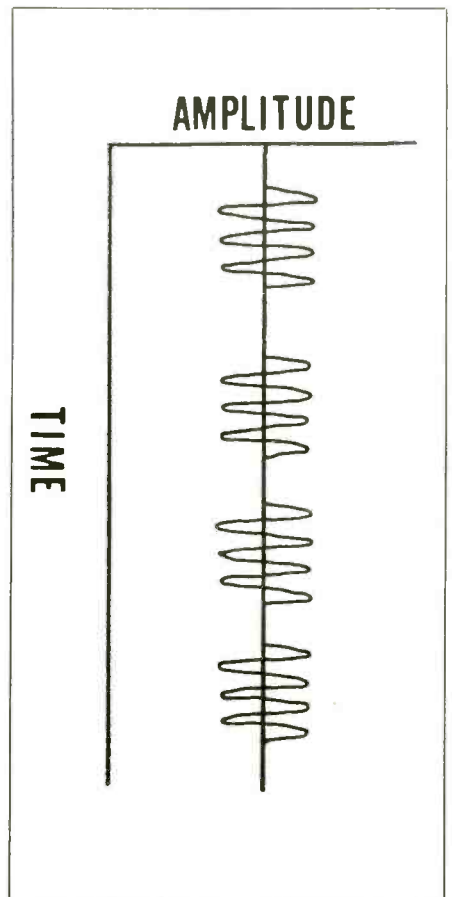

**Figure 3:** Four short pulses of undamped radio-frequency current.

## HEAR THE NEW BANDS ON YOUR SCANNER

Converts out-of-band signals to vhf or uhf scanner bands. Cables provided. Simply plug into scanner.

### 5 MODELS AVAILABLE:

- 806-894 MHz New Land Mobile Band
- 400-420 MHz Federal Government & FBI
- 240-270 MHz Navy/Air Force Fleet Satellites
- 135-144 MHz Weather & Geophysical Satellites
- 72-76 MHz Industrial & Radio Control

Scanner Preamps also available



**ONLY \$88 + \$3 S & H**

Order by phone or mail. Use credit card, check, COD. Or send \$1 for complete catalog by return mail.

**hamtronics, inc.**

65-B MOUL ROAD  
HILTON NY 14468-9535  
Phone: 716-392-9430

CIRCLE 3 ON READER SERVICE CARD

## INSIDE THE WORLD OF TVRO EARTH STATIONS

### Stereo Processing

The benefits of satellite television are apparent to all, from the crisp, clear video pictures to the wide selection of programs beamed down from space. But satellite receiving stations can also be equipped to satisfy the most demanding audiophile. Stereo processing equipment, until recently, has been an unusual addition to a homesat. However, in the whirlwind of advancing technology, this will soon be commonplace.

A selection of excellent radio stations as well as video networks such as The Movie Channel, The Nashville Network, and MTV are broadcast via satellite accompanied with stereo music and voice. Also, according to Hollywood sources, approximately 80% of major features filmed there will feature a stereo process developed by Dolby Laboratories. This is setting a trend for most quality video productions and will further enhance the sound that you can now receive through your stereo sound system with the aid of a satellite stereo processor. To see how these new technologies are mated, let's backtrack.

There are presently four types of stereo processors on the market. The discrete or brute force method is favored by Spotlight, in which the left and right channels are transmitted on two separate subcarriers in the range from 5.00 to 8.50 MHz. Most satellite video receivers on the market can tune onto numerous audio services relayed in narrow bands in this range. A second more sophisticated discrete technique has been developed by Wegener Engineering for Disney, The Nashville Network, and others.

The matrix method used by MTV and The Movie Channel also uses two separate subcarriers. One channel contains the left plus right audio intelligence (L + R) and the sec-

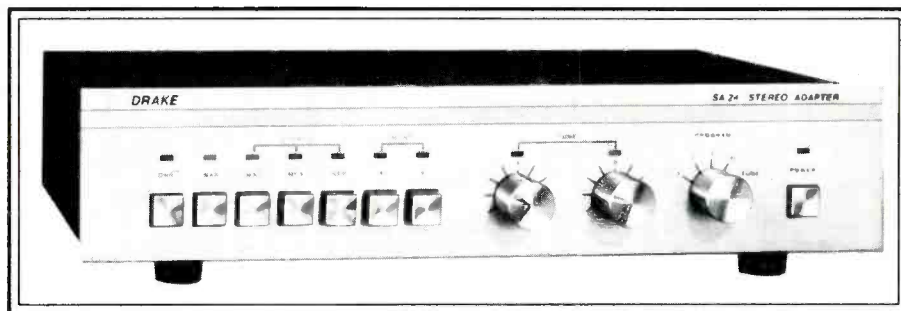

The Drake Stereo Adaptor.

ond contains L-R. The stereo processor then algebraically combines the two to produce a stereo output.

The multiplex stereo system, patterned after FM stereo technology and used by Bravo is more complex, but both audio channels are relayed by one subcarrier on the transponder band of frequencies. It uses an FM subcarrier for the L + R audio signal, and a double-sideband; there is suppressed AM "sub-carrier" also on the FM signal for L-R intelligence. In addition, a 19 kHz synchronizing signal is transmitted for stereo demodulator reference to aid in recovering the original signal (see Figure 1). The resulting signal reproduces either an monaural or stereo broadcast.

Virtually all of the stereo processors on the market today do an excellent job of decoding matrix and discrete stereo. The Wegener system, which is becoming the choice of virtually all new satellite audio services because of its excellent quality reproduction, presents a problem to some of the lower end processors.

It is interesting to note that the multiplex

radio stereo broadcasting technique was originally developed by Zenith and selected by the FCC in 1961. In March of 1984, the FCC authorized conventional over-the-air TV broadcasts with stereo sound. Even though it did not recommend a specific standard format, an industry subcommittee has suggested that the Zenith multiplex system be used.

Today's stereo processors retail for \$400 to \$500. But only about four manufacturers offer separate processors. The trend is to include the circuitry for decoding stereo within the video receiver.

For example, the Drake SA-24 Stereo Adaptor has the ability to process all the types of stereo signals by front panel push-button selection. It is compatible to any receiver having a subcarrier signal (composite video or baseband) output port. Four formats can be internally field programmed for instant selection of a particular program source and format. It also includes a noise reduction system which automatically adjusts system bandwidth as a function of signal amplitude and frequency content. The op-

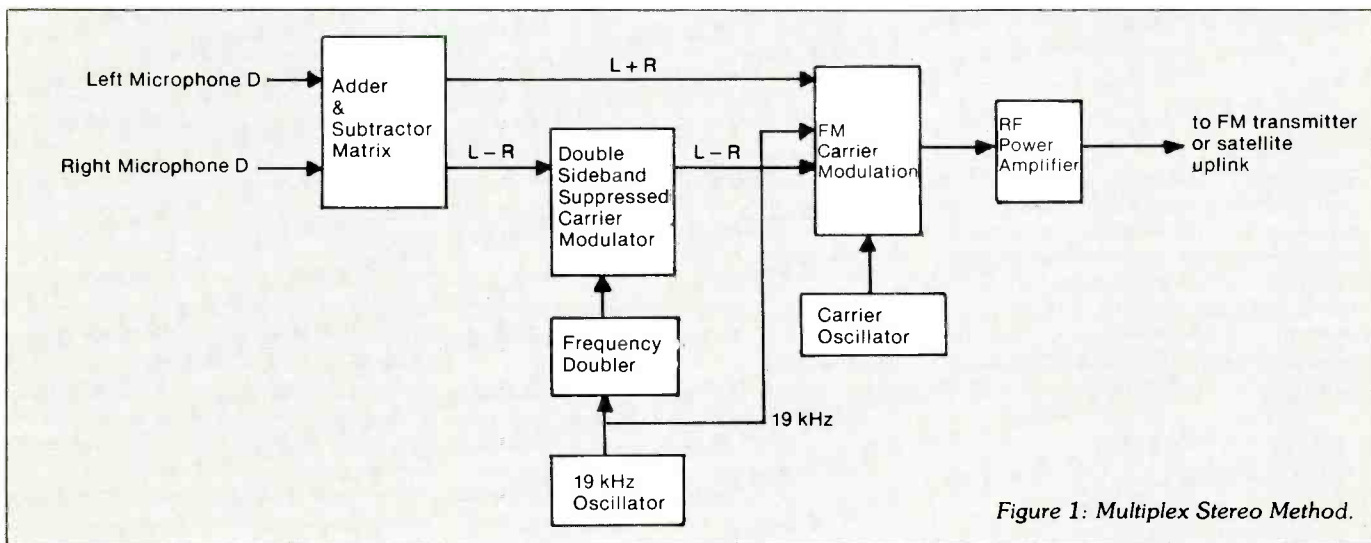

Figure 1: Multiplex Stereo Method.



## SECRET TELEPHONE RECORDING DEVICE

**SPECIAL HALF-PRICE OFFER**  
~~\$29.95~~ ONLY \$14.95

This fantastic miniature electronic device turns any tape recorder into a **SECRET PHONE BUG** that silently and automatically records both sides of your telephone conversations!

Connects any cassette tape recorder to your telephone **anywhere** along the phone line. Automatically starts tape recorder when phone is picked up, records **both sides** of phone conversation with **crystal clarity**, then turns recorder off when phone is hung up! Includes **all attachments**. Completely self-contained unit **never needs batteries!** Not to be used for surveillance. **ALSO**, our giant catalogue of laser weapons, surveillance devices, and much more is included **FREE** with every order! 100% **MONEY-BACK GUARANTEE**. Send \$14.95 + 2.25 shipping (\$17.20) to:

**UNIVERSAL SECURITY, Dept. PC-6,**  
 15015 Ventura Blvd., #1653, Sherman Oaks, CA 91403.

Or Send \$1.00 For Giant Catalogue

CIRCLE 87 ON READER SERVICE CARD

## CB MODIFICATIONS

Increase channels, range, privacy! We specialize in frequency expanders, speech processors, FM converters, PLL & slider tricks, how-to books, plans, kits. Expert mail-in repairs & conversions. 16-page catalog \$2.

**CBC INTERNATIONAL, P.O. BOX 31500PC,**  
 PHOENIX, AZ 85046 (602) 996-8700

Please send all reader inquiries directly.

## FREE

Attention Shortwave Listeners

Finally, a professional newsletter for the *serious* listener. For free sample copy send 37¢ US coins or stamps (70¢ Canadian) or 7 IRC's overseas to cover postage and handling to:

**Miller Publishing**  
 424 West Jefferson St., Suite B  
 Media, PA 19063

Please send all reader inquiries directly.

## UNSCRAMBLERS

FOR POLICE, FIRE & MEDICAL CODES  
 SATISFACTION GUARANTEED  
 SEND FOR COMPLETE INFORMATION  
**DNE, INC. — RT. 7, BOX 257C**  
 HOT SPRINGS, ARKANSAS 71901

**501-623-6027**

Please send all reader inquiries directly.

## COMPUTER PROGRAMS

Commodore 64—T199/4A—Timex/ZX super SWL/scanner log with store and search. T199/4A and Timex version—cassette \$10.00 postpaid. Commodore 64 version with extra features including local and GMT clock, disk or cassette \$15.00 postpaid. Order direct from this ad and take 10% discount, or SASE for information and other SWL/Ham programs.

**KENTRONICS**

**P.O. BOX 586**  
**VERNON, ALABAMA 35592**

CIRCLE 59 ON READER SERVICE CARD

## Stereo Satellite Services

### SATCOM F4

#### TR (transponder) Programming

Channel 2	BRAVO—cultural
Channel 3	Rhythm & Blues—Contemporary jazz/soul music
	Rock-A-Robics—Top 40 Rock
Channel 7	Family Radio Network (East)
	Family Radio Network (West)
	Sheridan Broadcasting Network
Channel 17	Satellite Jazz Network—contemporary & traditional jazz

#### Subcarrier

5.8 multiplex
5.4 & 6.3 discrete
7.38 & 7.56 discrete
5.58 & 5.76 discrete
5.94 & 6.12 discrete
7.38 & 7.56 discrete
5.58 & 5.76 discrete

### SATCOM F3R

#### TR Programming

Channel 3	Moody Broadcasting Network—religious
	Satellite Music Network—country coast-to-coast
	Country Coast-to-Coast—modern country music
	WFMT (FM) (Chicago)—arts/classical
	Bonneville's "Beautiful Music"
	Stardust—hits from the 40's, pop sounds of the 50's, popular hits of the 60's and many popular hits of the 70's (Daily, 24 Hours)
Channel 5	StarStation—adult contemporary (Daily, 24 Hours)
	The Movie Channel—broadcast in full stereo
	Music In The Air—Broadway/Hollywood Musicals in stereo (Daily, 24 Hours)
Channel 6	Music In The Air—country music (Daily, 24 Hours)
	Music In The Air—50's and 60's hits (Daily, 24 Hours)
Channel 7	ESPN—Sports in full stereo (Daily, 24 Hours)
Channel 8	Nice & Easy—Contemporary music
	Cable Jazz Network—Jazz music
	Love Sounds—Inspirational music
Channel 11	MTV—Music Television (Daily, 24 Hours)
Channel 16	HTN Plus—family oriented movies

#### Subcarrier

5.4 & 7.92 discrete
5.94 & 6.12 discrete
5.94 & 6.12 discrete
6.3 & 6.48 discrete
7.38 & 7.56
8.065 & 8.145 discrete
5.58 & 5.76 discrete
5.8 & 6.8 matrix
5.58 & 5.76 discrete
5.40 & 5.94 discrete
6.435 matrix
5.58 & 5.76
5.58 & 5.76 discrete
5.94 & 6.12 discrete
6.30 & 6.48 discrete
5.8 & 6.62 matrix
6.8 multiplex

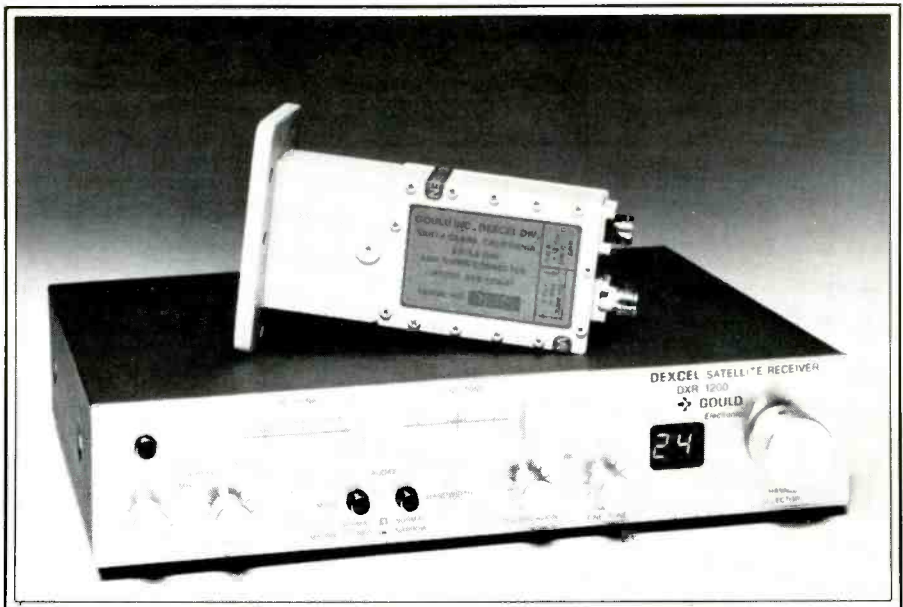

*Dexcel/Gould Video Receivers. These feature matrix and discrete stereo selection.*

eration can be mastered in a reasonably short time with the aid of a well-written operation manual.

Like others on the market, the Dexcel/Gould DXR 1200 stereo satellite system has a built-in stereo processor in the receiver. It features a selectable audio bandwidth control and two independently tunable channels for discrete and matrix stereo, which are switch selectable. Some more expensive

models have integrated stereo amplifiers and quartz synthesized tuning for discrete and matrix stereo. A handful of such receivers feature video graphic displays on your TV screen of time, date, channel, satellite program directory, signal strength, and audio format.

So either a separate or "built-in" stereo processor can offer high quality audio as a bonus to "monitor-quality" video. But we

## WESTAR 5

TR	Programming
Channels 10 & 12	The Disney Channel—family entertainment
Channel 17	The Nashville Network
Channel 23	ARTS
Channel 24	BET

## COMSTAR D4

TR	Programming
Channel 18	Country Music Television

## ANIK D1

TR	Programming	Subcarrier
Channel 16	CBBK-FM (Montreal, Quebec)—CBC Stereo Radio CBOF-FM (Ottawa, Ontario)—French. CBC Stereo Radio	5.4 & 5.58 discrete 5.76 & 5.94 discrete
Channel 18	CIRK-FM (Edmonton, Alberta)—rock	6.17 multiplex
Channel 23	CBOF-FM (Ottawa, Ontario)—French. CBC Stereo Radio CBBK-FM (Kingston, Ontario)—English. CBC Stereo Radio	5.4 & 5.88 discrete 5.76 & 5.94 discrete

## GALAXY I

TR	Programming	Subcarrier
Channel 4	The Disney Channel (East)—family entertainment	5.8 & 6.8 discrete (Wegener)
Channel 14	The Movie Channel (West)—family entertainment	5.8 & 5.76 discrete
Channel 24	The Disney Channel (West)—family entertainment	5.8 & 6.8 discrete (Wegener)

can go one step further and follow Dolby's lead to recreate the theatre in the home. This Dolby system features noise reduction and a four-channel decoding system known as SQ. Quadrasonic audio, which enjoyed a rather brief period of public interest in the late 60's and early 70's, is now much improved and making a comeback. Dolby's adaption of the SQ system has set a defacto industry standard among the competing quad methods.

As well, today there is plenty of video material available on satellite, cable, video-discs, and videocassettes—so quad may be here to stay. Satellite television can be one of the most supportive medium for this enhanced audio technology because such a wide variety of video is being downlinked to a rather innovative group of consumers.

Stereo output from the video receiver or stereo processor can be fed into an SQ processor such as the Fosgate Research Tate II (which retails for approximately \$575). The Tate II drives a stereo receiver and a second stereo amplifier which both power four speakers. The result is theatre-like sound. Add this to a quality TV or video monitor and even the most critical will be dodging Buck Roger's laser bullets as they fly past our ears.

If you would like to learn more about satellite television, *Satellites Today*, *The Complete Guide to Satellite Television*, is available from ConSol Network, P.O. Box 12098-M, Boulder, CO 80303. The price is \$9.95 plus \$1.00 for postage and handling.

**PC**

## DOUBLE YOUR RANGE Metz Tuned Base-Loaded Whips

Replace Your Telescopic Whip With The Metz System. Metz Whips Plug Into Your External Antenna Connector. Right angle SO 239 supplied. For scanners use Radio Shack 278-208 adapter. Bracket supplied for outdoor mounting.

- Two Models: Scan 1 covers 30 MHz to 512 MHz  
SW 1 covers 50 kHz to 54 MHz
- All stainless steel—won't corrode
- Tuned coils offer 3 dB gain over telescopic whips
- Every coil tested and serialized
- No external power required
- Whip only 54" tall
- Antenna may be mounted mobile with accessory \$25.00 magnetic mount
- Cannot be damaged by lightning

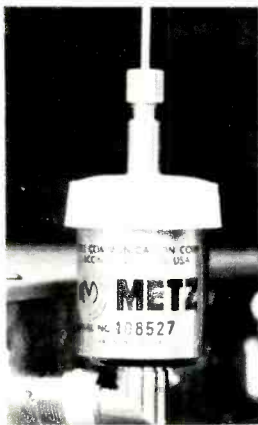

Metz stainless steel antennas are used worldwide by Mariners, Police, Business, and Commercial Radio users. It was the Ham Radio operators who discovered the phenomenal range increase when used on Ham worldwide and VHF equipment. Well-known radio expert Gordon West, WB6NOA, gives the Metz whips his highest rating: "They equal the range of active antenna systems at one-third cost, and when you replace your telescopic whip with the Metz, you'll really hear the difference!" \$59.95 from

**Metz Communication Corp.**  
corner Rt. 11 & 11C,  
Laconia, NH 03246  
Phone Orders Only:  
800-258-4680

(Visa/MasterCard/C.O.D.)

Shown mounted directly to receiver with supplied adapter. **Absolutely No Personal Checks**  
Amateur antennas for 2 Meter & 440 MHz also available. **Technical Info: 603-528-2590**

## GOT A SECRET?

We can help you keep it.



For your protection against listening devices that are not detectable by conventional methods, RESEARCH ELECTRONICS, INC. has developed the ANG2000 ACOUSTIC NOISE GENERATOR.

By producing a security blanket of generated noise; devices such as wired microphones, contact or spike mics, transmitters located in AC outlets and laser/microwave reflection from windows become inoperative.

Various transducer adapters are included with the ANG2000 for coupling to walls, ceilings, plumbing, windows, etc.



1570 BROWN AVENUE, COOKEVILLE, TN 38501  
Phone (615) 528-5756 Telex 786592

Call for information or send \$5.00 for Catalog (refundable upon purchase)



# PIRATES DEN

BY DARREN LENO, WDØEWJ

## FOCUS ON FREE RADIO BROADCASTING

**R**adio station KLS is a newcomer to the shortwave pirate scene, but not to pirate radio. KLS has existed in one shape or form since 1972. It operated in the AM and FM broadcast bands of an American city, which for security reasons, I cannot reveal. Perhaps it's your city.

Not long ago I paid a visit to this city, and, at the invitation of the operators, had the chance to stop in and visit with the KLS staff. I was quite impressed with the broadcast studio. The equipment included a 50 watt Viking Challenger transmitter that had been modified and rewired to meet the staff's audio quality requirements. A 30 watt RCA power amplifier is used as the modulator.

Two professional quality Garrard turntables with Empire Gold tone arms, a professional RCA soundboard, reel to reel and cassette tape decks, and studio microphones with booms make KLS one of the most outfitted pirate stations I've visited—and, the operators hope, one of the best stations you'll ever hear.

The DJs have extensive electronic backgrounds. One of them said, "We're trying to make this as professional an operation as possible." From the looks of their setup, they've got a good start.

Listeners should look for KLS between 7370 and 7450 kHz during weekend evenings. Reception reports can be sent to KLS Shortwave, PO Box 982, Battle Creek, MI 49016.

### Across The Dial

**Radio Clandestine:** This station was heard by another pirate, "Capt. Jack" of 21.52 MHz Atlantic Radio. Jack reports Radio Clandestine on 7354 kHz from 0300 GMT and comments that the program was "most enjoyable."

Lewis Darrah of Iowa noted Radio Clandestine "with outstanding audio" on 7372 kHz after 0600 GMT.

Reception reports for this station go to PO Box 982, Battle Creek, MI 49016. Don't forget to include at least 3 mint First Class stamps.

**Radio Foxtrot?:** Richard Rupp of New Mexico tuned into a pirate playing new wave rock music on 7370 kHz until 0700 GMT. Unfortunately, he was not able to catch a clear identification announcement. After listening to the recording he made of the station several times, he decided the ID sounded like "Radio Foxtrot, or Foxtrot."

**Radio Free Insanity:** According to Scott McClellan of Michigan, RFI has been fined \$1000 by the Federal Communications Commission for operating an unlicensed transmitter.

Reception reports are still being verified and should be sent with 3 First Class stamps



*KLS is a well equipped pirate station.*

to the Battle Creek, Michigan address we mentioned previously.

**GAN Int'l:** When Kirk Baxter of Kansas heard this station on 7324 kHz after 0500 playing rock music and Public Service announcements, he thought for a moment he was tuned to a legitimate station.

Grant Lochmiller also heard GAN Int'l and enjoyed listening to a feature about Radio Caroline, the British offshore pirate

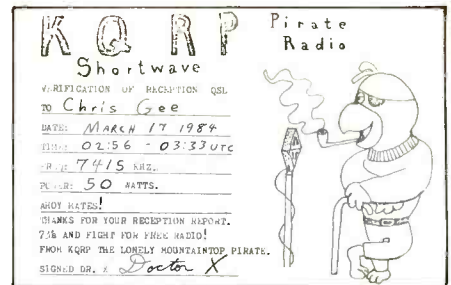

*Another version of a QRP QSL card.*

station. A possible address is Box 222064, Dallas, TX 75222.

**KMA:** Nick Agos of Illinois heard the end of KMA's Pirate Radio News program, featuring items from A\*C\*E's newsletter and this column, during a broadcast on 7410 kHz after 0030 GMT. Reception reports should be sent to KMA Radio, PO Box 3192, Joliet, IL 60434.

**KPRC:** New York City's AM, FM, and SW pirate continues to be heard. Kirk Allen of Oklahoma noted them on 6275 kHz after 0600 GMT.

East Coast readers should also listen for this station on 1616 kHz and on 91.5 MHz FM. Reception reports go to KPRC, PO Box 542, Exeter, NH 03433.

**KQRP:** This pirate continues to be widely heard by POP'COMM readers.

Chuck Gunkel of Oklahoma logged KQRP with DJ "Dr. Rick" on 6233 kHz at 2347 GMT.

Minnesota DXer Andrew Wertheimer noted them on 7413 kHz with 6210 kHz in parallel after 0210.

*KLS uses a 50 watt Viking Challenger transmitter and an RCA soundboard.*

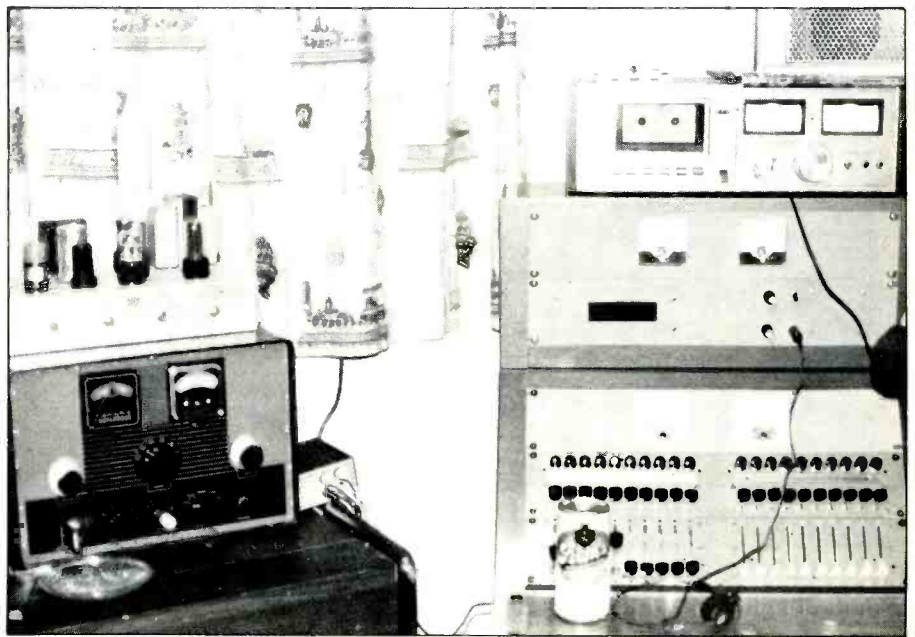

"Dr. X" was on the air when Robert Hynd of California tuned in to 15050 kHz after 1830 GMT.

"Capt. Jack" heard KQRP from 0410 to 0425 kHz on 6233 kHz as they played music by the Beatles.

John Norfolk heard KQRP after 2300 on 6233 kHz as they relayed a fellow pirate, "The Sons of Ireland." John says, "KQRP has been fairly active lately, heard here seven times in the past two months." I think fairly active is an understatement, John!

KQRP is known for promptly verifying reception reports. Send them to the Battle Creek, Michigan address mentioned earlier.

**KW Radio:** In Oregon, Tracy Wood reports hearing KW Radio on 7435 kHz after 0500 GMT.

Tracy's catch comes as a surprise. KW Radio was the name of a New York City pirate that operated on 1610 kHz in 1982. FCC officials caught up with the station on December 5 of that year. Not much had been heard about KW Radio since it was busted. Is this the same station, or just another pirate keeping the name alive?

**Secret Mountain Laboratory:** This new pirate was testing their 20 watt transmitter when Paul Walkendorf of Michigan tuned in at 2002 GMT on 7432 kHz. SML was playing country, folk, and even some Arabic music.

**WARO:** "The station of roots rocking music" is a new pirate operating in the 11 meter band. DJ "Dr. Hip" encourages listeners to tune 27105 kHz between 2300 and 0100 GMT, local Sundays.

**WIMP:** Chris Gee of Virginia was happy to hear "WIMP-Nerd Radio" on 7430 kHz after 0230 GMT. The station requested that 3 First Class stamps be included with reception reports to the Battle Creek address.

**WWCC:** This new pirate was heard by Frank Decker of New York on 1617 kHz after 0600 GMT. Phone calls were solicited through a telephone-loop line, but technical problems prevented eager listeners from getting through.

### Euro-Pirates

Podney Sixe of Cornwall, England, sends these tips for those North American DXers who enjoy the ultimate challenge in Pirate-DXing—the European Free Radio stations.

Radio Sylvania, PO Box 600 431, 2000 Hamburg, West Germany, operates the second Sunday of every month from 1000 to 1200 GMT on 6225 kHz.

Radio Atlantis SW, c/o Box 700 825, D-2820 Bremen 75, West Germany, appears on 6200 kHz after 0930 GMT.

Radio Caroline has been relayed by an unidentified station on 6288 kHz. As far as we know, this is a case of a pirate pirating a pirate's signal.

Radio Caroline broadcasts to Europe on 963 kHz from the ship, *MV Imagine*.

Spectrum World Broadcasting has been known to operate on 7710 kHz, 6275 kHz, 9960 kHz, and 13733 kHz, GMT weekend mornings.

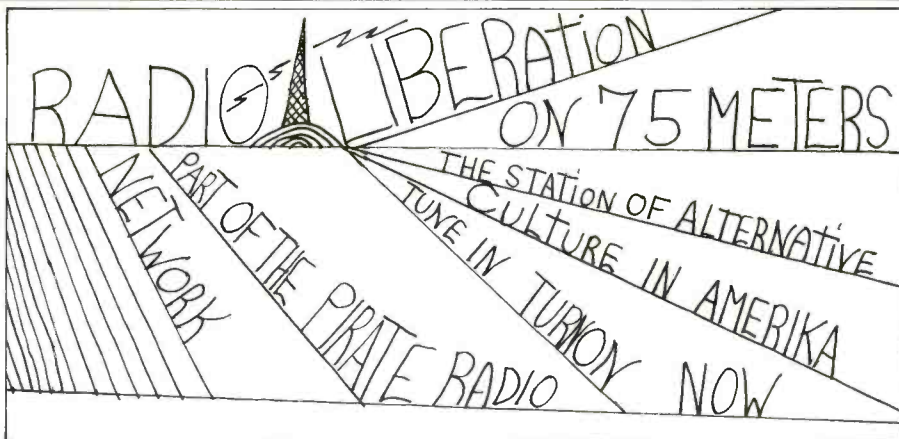

### Chinese Clandestine Radio

Steve Anderson of California sends a news article which appeared in the *Los Angeles Times*.

It appears that as many as four black propaganda clandestine stations are broadcasting distorted news stories with hopes of stirring unrest among the Chinese people and discontent toward their government.

The stations are October Storm, Voice of the People's Liberation Army, Contingent of Proletarian Fighters, and Radio Spark.

Radio Spark is thought to take its name from either a revolutionary underground Russian newspaper or from Mao Tse-tung's assertion that "a single spark can start a prairie fire."

It is not known exactly who is behind this clandestine radio network. Western monitors believe that the transmissions may be originating from a ship anchored in the South China Sea, with Taiwan as a probable sponsor.

The transmissions are made in the short-

wave band, but specific frequencies were not available.

### Finishing Touches

RADIOTELEX publishes the latest European Free Radio news directly from Europe. For a sample of their news bulletin and subscription information, send \$2.00 to RADIOTELEX, PO Box 700 825, D-2820 Bremen 75, West Germany.

A reader sends notice that *Flip Side* magazine, issue #42, carried an article on pirate radio stations. If you're interested in obtaining a copy of the article, entitled "Anarchy on the Airwaves," write *Flip Side*, PO Box 363, Whittier, CA 90608.

I'd like to thank the fine shortwave listeners who participated in The Pirates Den this month. POP'COMM readers are invited to send in their pirate loggings, copies of QSL cards, pennants, tips, etc. to The Pirates Den, c/o Popular Communications, 76 N. Broadway, Hicksville, NY 11801. See you next month!

PC

**Telephones & Accessories**

**AT LOWEST PRICES**

- Cordless Phones
- Memory Phones
- Answerers
- Dialers
- Hardware
- Speaker Phones
- Call Diverters
- Feature Phones

Send for Complete Catalog

**UNIQUE COMMUNICATIONS, INC.**  
181 E. Longview, P.O. Box 5234  
Mansfield, Ohio 44901  
(419) 526-6996

CIRCLE 60 ON READER SERVICE CARD

### Enjoy Your Radio Hobby



Now Available  
**144 Page Book**  
Covering U.S. Canada  
& Worldwide Shortwave  
AM, FM & TV Stations  
Cross-indexed by  
Frequency, Location & Call Letters  
A DXers Delight for 60 Years

**Only \$6.35 (ppd)**  
**SEND FOR YOUR COPY TODAY!**

NAME: \_\_\_\_\_  
ADDRESS: \_\_\_\_\_  
CITY: \_\_\_\_\_  
STATE: \_\_\_\_\_ ZIP: \_\_\_\_\_

**CLIP AND MAIL COUPON TODAY TO:**  
**WORLDWIDE PUBLICATIONS INC.**  
P.O. BOX #5206, NORTH BRANCH, N.J. 08876  
(201) 231-1518

Please send all reader inquiries directly.





ZCZC WRC153  
 USSF1 LEMM 190000  
 TTA 68231 08001 99011 18650 03014 00163 17843 03013 85551 15263  
 07522 70162 03658 06017 50581 12564 04523 40748 23969 05039 30951  
 40562 05544 25072 50358 0504 20216360 06045 15399 56165 05511  
 10656 57570 0254 88199 56560 06045 799;  
 TTA 68231 08221 99947 17625 09001 00160 // // // // 8547 12026  
 14514 70145 02226 15519 50578 15160 19031 40744 24735 19012 30947  
 40950 21504 25068 5:557 17534 20214 52166 20538 15398 55968 18517  
 10654 58969 15511 88251 50357 17534 88173 57167 21025 77999;  
 TTA 69001 08302 99015 21846 06010 00174 21257 07510 85576 19866  
 15010 70208 06860 20525 50588 11349 24539 40755 22559 23040 30959  
 39359 24561 25081 50160 23565 20223 59166 25062 15403 605// 24022  
 10656 621// 22521 88196 59766 25062 77228 24575;

W  
 NNN

GLGL

LAT0157 4 /AFF-PH79  
 BELAUNDE-DEPORTES

LIMA JUN 16 (AFF) - EL PRESIDENTE PERUANO FERNANDO BELAUNDE INSTALO ANOCHE EN LIMA AL PATRONATO NACIONAL DEL DEPORTE, ORGANISMO PRIVADO QUE SE PROPONE CONSTRUIR CAMPOS DE JUEGO EN TODO EL PAIS PAR FOMENTAR LA CULTURA FISICA Y EL DEPORTE DE LA JUVENTUD.

EL JEFE DE ESTADO, QUIEN FOCO ANTES DE LA CEREMONIA, EFECTUADA EN EL CLUB REGATAS LIMA, HABI SUSPENDIDO LOS IMPUESTOS AL DEPORTE PROFESIONAL, DIJO QUE APROVECHARA SU VISITA DE LA PROXIMA SEMANA AL BRASIL PARA RECOMENDAR EL INTERCAMBIO DE DEPORTISTAS ENTRE LAS DOS NACIONES.

HF.NZ  
 AFF 161927 GMT JUN 84

Figure 2.

combines several forms of modulation, including Single Side Band (SSB), Independent Side Band (ISB), and RTTY (all modes). The very capable Webb Linznayer wrote the technical details of the RTTY section and our own Tom Kneitel opened the *Confidential Frequency List*. This super book can be purchased by writing to Gilfer Associates, 52 Park Avenue, Park Ridge, NJ 07656, or by noting the ads in this magazine. Jeanne Ferrell was stunned by the amount of material present on her word processor. In the final phases of editing this new book, the decision was made to keep all of the listings rather than to remove "older" listings. This was an excellent decision due to the sporadic nature of certain utilities. RTTY utilities can be silent for a complete season only to come back transmitting again.

Many of the listed frequencies are from the International Telecommunications Union (ITU) and appear on HF infrequently. The point of random appearance of point-to-point RTTY utilities makes any removal of frequencies suspect and requires extensive research in order to indeed know the status of each. My philosophy is, if in doubt, leave it in. The *Confidential Frequency List* is highly recommended as a convenient information guide.

As I mentioned last month, new RTTY demodulators crop up monthly. Notable for the RTTY buff is the AEASOFT™, SWLTEXT™, MORSE, BAUDOT, ASCII, and AMTOR software. AEA is located at P.O. Box C2160, Lynnwood, WA 98036-0918. All of the software is contained in EPROM on a PC board. The EPROM is a single "chip" and allows immediate access to the actual program rather than waiting for the software to be loaded into the memory from disk or cassette. By simply turning on the

Commodore 64, the program's menu pops up after an O is pressed.

This program is the most advanced RTTY software on the market, with the exception of the stand-alone complete INFO-TECH M600A demodulator/display unit. Advanced features include timing analysis, bit inversion, third-register cyrillic display, ARQ and FEC modes. Once the RTTY signal is timed in (with any suitable demodulator), type T on the Commodore to start the analysis. After several seconds, the baud rate, type (BAUDOT or ASCII), and normal or inversion format appears on the CRT. If the overall RTTY signal is weak, a "possibly" header pops up indicating inconclusive results. An extremely noisy signal is flagged as "noise" on the CRT. A few commercial RTTY transmissions use a privacy technique known as bit inversions. One or more data bits (possible start or stop bits) are inverted. Where a mark condition existed, a space is substituted. The SWLTEXT™ program will review all combinations until plaintext appears. Even the popular error correcting code FEC (forward error correction) is a menu option with SWLTEXT™.

My only complaint of this fine program is the lack of compatibility with other computers. Currently, SWLTEXT™ is only available for the Commodore 64 computer. We would also like to see this software available for several other computers—Apple, IBM, and MAC would be low noise hosts for SWLTEXT™. The manual should be organized for the RTTY beginner and proceed to the more advanced techniques.

AEA will package the SWLTEXT™ with the Computer Patch (CP-1) modulator.

Figures 1, 2, and 3 illustrate the wide diversity of RTTY signals found on HF.

See you next month!

PC

## R-390A HF RECEIVER



Famous military receiver covers 0.5-32 Mhz AM-CW in 31 one Mhz bands using mechanical digital tuning. 455 KHz IF, has four Collins mechanical filters for selectable 2-4-8-16 KHz bandwidth. 100 KHz calibrator. BFO. No covers. 115/230 VAC 60 Hz; 10 1/2 x 19 x 16 3/4". 95 lbs. sh. (UPS in 2 pkgs.). Used-repairable \$215. Checked \$335. Manual, partial repro \$15.

**PARTS FOR R-390A**, used-checked:  
 PTO/VFO assembly \$50 If Collins Mfg ..... \$65  
 Mechanical filters 2 or 4 KHZ ..... \$50  
 8 KHZ ..... \$40 16 KHZ ..... \$30  
 Power supply less 2625 tubes..\$45. Most other parts available, except meters. Write for listing.

Prices F.O.B. Lima, O. • VISA, MASTERCARD Accepted.  
 Allow for Shipping • Send for New FREE CATALOG '84  
 Address Dept. PC • Phone: 419/227-6573

### FAIR RADIO SALES

1016 E. EUREKA • Box 1105 • LIMA, OHIO • 45802

CIRCLE 70 ON READER SERVICE CARD

## SHORTWAVE LISTENERS

### RADIO WEST FERRITE LOOP

The Best Broadcast Band Ferrite Loop Antenna in the World!  
 Covers 150khz to 5Mhz  
 18" of Ferrite! High Gain!  
**\$160 plus UPS**

**Catalog \$1.00 - Refundable**  
 3417 Purer Road  
 Dept. PC  
 Escondido, CA 92025  
 (619) 741-2891



CIRCLE 142 ON READER SERVICE CARD

## Shortwave Receivers, Antennas

ICOM - KENWOOD - YAESU Etc.  
 Call 1-800-221-2683 Toll-Free US  
 (212-925-7000 New York State)  
**Barry Electronics**

512 Broadway • New York, NY 10012  
 Sales & Service Ham & Commercial Radio  
 For 35 Years

CIRCLE 36 ON READER SERVICE CARD

## JR. TROOPER CAMOUFLAGE

*Jungle fatigues for your little soldier.*

Just like the Army's Battle Dress  
 Utilities - 4 pocket top, 5 pocket pants  
 - reinforced seat, knees & elbows.  
 Easy care 50/50 Nylon Cotton Twill.

Size 8-16.  
 BJF71, Trooper Top \$21.95  
 BJF72, Trooper Pants \$21.95  
 Send FREE 96 page catalogue loaded with survival, hunting, camping & military gear.

Send check or Money Order to:

**Brigade Quartermasters, Ltd.**

266 Roswell Street, Sept. 70J, Marietta, GA 30060  
**Money Back Guarantee**



Please send all reader inquiries directly.



# PRODUCTS

## REVIEW OF NEW AND INTERESTING PRODUCTS

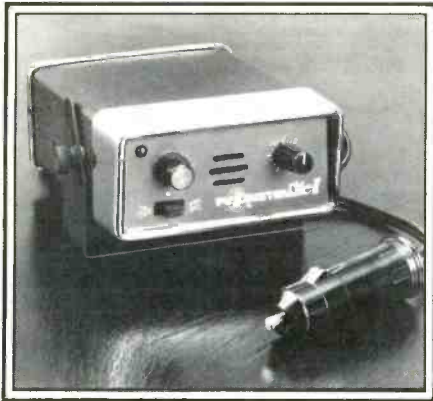

### Fuzzbuster Elite II Radar Detector

The Fuzzbuster Elite II claimed to outperform other conventional radar detectors through the use of a unique "Phase Locked Filtering" system (PLF). PLF enables the Fuzzbuster Elite II to automatically reject signals from non-radar sources.

Fuzzbuster Elite II, a multiband detector, picks up all types of police radar: moving, low power, PLL, pulse, or hand gun.

Its outstanding features are: Visual radar indicator, audio range system, warning mode switch, sensitivity control, power indicator light, and universal mounting bracket for quick and efficient dash mounting.

Constructed of durable all-metal casing, the unit measures 3 3/4" wide x 5" deep x 2 1/2" high (including bracket). Ship weight is 3 lbs. The Elite II has a suggested retail of \$129.95.

For further information on this new detector, write: Electrolert, Inc., 4949 S. 25A, Tipp City, OH 45371, or circle number 105 on the reader service card.



### Subcarrier/Carrier Current Detector

This new, low-cost detector allows for quick checking of power lines for hidden "wireless intercoms" or "FM room monitors." In addition, phone lines can be checked for carrier current transmitters.

When used in conjunction with a radio receiver, subcarrier transmissions can be demodulated.

The new detector has a sensitivity of 6 $\mu$ V, which allows it to detect signals other detectors may miss, and can be tuned from 10 kHz to 690 kHz. A high-pass filter can be switched in above 40 kHz to eliminate or reduce noise. An audio amplifier and speaker are built-in.

For more information contact Viking International, P.O. Box 632, Newhall, CA 91322, or circle number 107 on the reader service card.



a small (35 x 17 x 24 mm) control unit which can be up to 50 meters (160') from the rest of the radiotelephone station.

DANMAR's RT-210 is a solid state 400 watt PEP, full duplex transceiver based on digital frequency synthesis. The transmitter part covers the frequency band from 1.6 to 30 MHz in 400 programmable channels; or free frequency selection in 100 Hz steps, the receiver covers from 100 kHz to 30 MHz tuning in 10 Hz steps.

Switch time from transmit to receive mode is 0.9 seconds, maximum 1.0 second. Frequency selection and antenna tuning can be automatically controlled. The RT-210 is prepared for automatic Radiotelex systems.

The set consists of the control unit (RT210) and a compact transceiver unit (T210) with fully all-band automatic antenna tuner. The system is controlled by a microprocessor. The control unit has a built-in loudspeaker and connection possibilities for micro-telephone, ARQ Radiotelex system, and others. Operation is performed by a keyboard and dial controls, and the operator can select, transmit, and receive frequencies via the numerical keyboard.

All transmitter and receiver circuit and a switch-mode power supply are contained in the control unit. The equipment may be connected to a 24 or a 32 vdc supply by optional 90/145 or 175/290 vac external power supply with automatic switch-over from AC to DC in case of power failure.

The antenna tuner and transceiver unit (T210) is designed for internal installation as close to the antenna as possible. Tuning is performed automatically without any pre-setting or adjustments at the installation.

The tuning time (0.9 sec.) is actuated the moment the handset is removed from its cradle. The automatic antenna tuner covers all bands.

For additional information, contact: Marine Exposition & Marketing Associates Comp. (M.E.M.A.C.), Box 204, Boca Raton, Florida 33429, or circle number 104 on the reader service card.

PC-84 **Antenna Accessories For Personal Communications**

**A Dime On The Antenna Is Worth A Dollar On The Radio**

So goes an old ham saying. It takes a lot of extra transmitter watts to overcome an inefficient antenna.

That's why we at Unidale Rayco specialize only in accessories to make your antenna more effective. We believe that the ancient, simple dipole is the best all-around affordable antenna. We don't quarrel with special types for special jobs. But for low cost simplicity and effectiveness, even for the novice, the dipole has stood the test of time—for over half a century. Most of our products relate to the dipole. Baluns to keep it balanced and efficient. Traps to give it multi-band capability and Coaxial Relays to manage interconnections. And of course, insulators. Wire and other hardware to make construction simple.

All our leading products have at least two other in common: each one was designed by an accomplished Ham and has been widely accepted for many years by Amateur, Commercial and Military communicators alike. Both in the US and at least 50 countries around the world.

The W2AU ("Big Signal") Balun was developed by Paul Wendell W2AU of course, over 20 years ago. This world famous product is the preferred balun for domestic and overseas Ham, commercial HF equipment operators and certain segments of the US Armed Forces. For example, Canadian Marconi, a world renowned manufacturer of military radio equipment, includes the W2AU as a component of several military field sets.

The W2V5 Trapless Antenna Cable, was developed by Fred Reynolds, W2V5, over 18 years ago. They are in wide use around the world by Ham and commercial operators. For example, they are used in the multi-band communications of a number of police agencies and others who must coordinate multiple site operations.

The Intra Coastal Relay had their beginning in 1981, when Sam Lacker, W1NBD, designed and built some to eliminate multiple cables on the antenna farm in Moncksie, New Hampshire. The original relays are still operating (incidentally). Equipped on by requests from other amateurs, Sam went into production and, over the years, created a whole system of relays which can be used to remotely select from up to nine antennas and perform a still of other useful chores to permit tower-closing. Although Amateurs make up the largest group of users, these relays are also extensively used in commercial, industrial, CATV and marine radio systems.

You can use our products with confidence, knowing that they have been designed for your needs by operators, users and have endured long and successful use before we offer them to you. What's more, we've been around a long time—and expect to be here when you need us.

To order Unidale Rayco line products, first check the list of local dealers included with the catalog. If there's not a dealer in your locality, then order directly from the factory—or call us—Toll Free.

**Unidale Rayco**  
A Division of Microwave Filter Co., Inc.

3713 Kinne St., East Syracuse, NY 13057  
Tel./Fax: (315) 481-1888; Telex: 710511-0493  
MFR: CAN/Canada (CSH) 314-437-3992

### HF Antenna Accessories Catalog

Catalog PC/84 from Microwave Filter Co. describes Baluns, multiband traps, and remote antenna switching relays for the 2-1000 MHz communications bands.

The catalog illustrates the construction of single and multiband dipoles in the 1.8-30 MHz Amateur and HF communication bands and offers other construction accessories such as end insulators, weatherized center feed insulators, wire, cable, and connectors.

The system of remote, voltage-controlled antenna switching relays allow selection of up to 9 separate antennas through a single coaxial cable as well as direction changing of antenna arrays and automatic pairing of antenna/transmitter sets.

For a copy of this free catalog, contact Microwave Filter Company, Inc., 6743 Kinne St., East Syracuse, NY 13057, or circle number 108 on reader service card.

### New Radiotelephones

With its new RT-210 series, DANMAR of Denmark says it is introducing a new generation of HF/SSB radiotelephones which break away from many traditional operating and technical concepts.

One feature is that all operations and adjustments of the RT-210 are carried out from





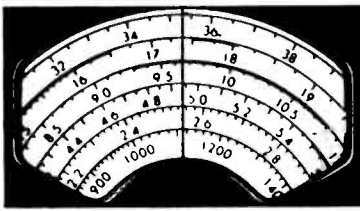

# COMMUNICATIONS CONFIDENTIAL

BY RON RICKETTS, WA5VFA

## YOUR GUIDE TO SHORTWAVE "UTILITY" STATIONS

Some months back, we requested our readers to send copies of their more unusual QSLs, and Ken Kimura of New York has responded with a pair of cards from the U.S. Navy. What makes them out of the ordinary is that they are from "RAT" and "SWING," Naval Reserve aircraft on training missions. "Swing-50" is a C-9B Skytrain II, the military version of the DC-9. Likewise, "RAT-20" is a C-118B Liftmaster, which in civilian life is the venerable DC-6, now in its third decade of service. Transmissions of these and similar Navy aircraft may be heard on 11182 and 13244 kHz. Thank you, Ken, for sharing this with the readers of POPCOMM.

### An Oriental Numbers Station???

Daryl Duckworth of Colorado sends a logging of more than passing interest. In it, he indicates that he has heard a 4-digit Oriental numbers station. At 1230 on 10725 he heard a female announcer speaking 4-digit (4-syllable?) groups, each repeated twice. Daryl says that it does not appear to be Korean or Japanese, but some dialect of mainland Chinese. After a long string of groups, there was what appeared to be a sentence of speech and then resumption of groups. During this time, the band was open to the Orient; Radio Korea's interval on 9750 was 20 dB over S9. Any of our Chinese speaking readers might want to monitor this frequency to verify Daryl's logging and perhaps pass along some additional information. He indicated that the carrier was quite strong but that modulation was low, which is typical of many numbers transmissions. Sometimes poorly modulated signals are more easily understood if tuned in SSB mode.

### More On The Mystery Beacons

Reed Darsey of Alabama has written to tell us about unusual signals heard in the 2050 to 2149 kHz band in his area on the Gulf Coast. These signals appear only in this boundary and never elsewhere. When these signals are tuned in SSB, they are a collection of chirps and beeps, the beeps coming once a second. Additionally there are blank places in the transmissions so that the cacophony of chirps, beeps, and blanks are quite bizarre. These signals are quite strong in his location. The strength changes drastically from minute to minute during his monitoring sessions. He indicates that he has found no explanation for these transmissions.

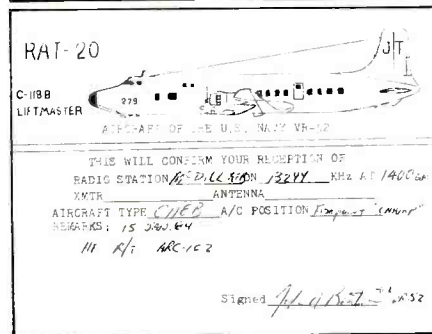
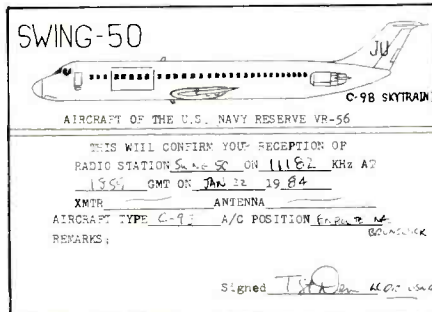

*C118B is actually a military version of the DC-6 and was procured during the early 1950's, now entering three decades of service. Similarly, the C9B is also a military version of the DC-9.*

George Sassoon of Argyll, Scotland also writes concerning similar transmissions in his vicinity. There is a particularly noisy one on 1950 kHz, which behaves in a similar manner to Reed Darsey's that has been dubbed "the sausage machine" by George's ham friends. It churns out an endless supply of wobbly bleeps, as if there was a component of phase modulation. George says that rumor indicates this to be a precision navigation system used by oil rigs in the North Sea for positioning over wellheads.

At my location in the Fort Worth, Texas vicinity, I have heard similar signals nightly for quite some time coming from the general direction of the Gulf Coast. I too had been curious and had assumed them to be some kind of radiolocation system. The source of these transmissions seems to be explained readily in a letter from David W. Peery of Singapore, who is an employee to Offshore Navigation, Inc.

David writes to explain that his company operates six radio positioning stations in the U.S. mainly in the Gulf of Mexico. The one most frequently heard is called Raydist, of which there are three basic types. Type N requires a Master and at least three slave stations, operating in the 1600 to 1800 kHz band with 100 watts of power. With this

system, the mobile unit (on board a survey vessel or pipe laying barge) does not transmit. Sometimes the mobile station will also be equipped with the type DR Raydist on board which allows a finer increment of location within the 600 foot lanewidth of the type N Raydist. In this situation, the mobile unit will transmit in the 3300 to 3400 kHz band also. The third Raydist system is called RAC (Radio Positioning Atomic Clock) which uses a cesium clock to maintain synchronization. Each of these three systems uses a maximum power of 100 watts and have an FCC designation of .1A0, 1.7A2 for type N; .1A0, 1A2 for type DR; and .1A0 for the RAC.

In addition to Raydist, another type of radiolocation system is called Microphase. It operates in the 1600 to 1800 kHz band using 100 watts and type .1A0 emission.

The latest system out uses a bandwidth of 152 kHz in the 1600 to 1800 kHz band. This system, called SPOT, uses spread spectrum transmission rather than CW. One pseudo random sequence is 48000 cycles long, meaning that 4000 discrete frequencies (spectral lines) are separated by 38 Hz. Therefore, with an overall bandwidth of 152 kHz, a 100 watt transmission is divided such that each frequency is only allocated .25 milliwatts of power to the antenna.

David points out that some of these stations used to periodically send a CW ID. Last year, the FCC waived the requirement as the stations may be on for six months at a time. Offshore Navigation, Inc. currently has 45 stations just in the Gulf of Mexico from Florida to the Mexican coast. They are turned on and off as clients require them. This would account for the sporadic operation noted by listeners. In Reed Darsey's situation, it would be a safe rationalization that he is hearing SPOT transmissions from very close by, considering the signal strength noted. Because of the unusual nature of the transmissions, it is also quite possible that the disparity in frequency comes from hearing an image, caused by overload. Thank you, David, for your detailed explanation of the navigation systems operated by ONI.

### Shortwave Log — A Valuable Reference Tool

The beginning UM (utilities monitor) is usually bewildered by the variety of signals pouring from his receiver. Much of what is heard may be unfamiliar to him, and at this time he needs something to guide him in his search through the bands. Many of the published frequency lists contain stations that

are seldom heard outside the country of origin and are inaudible in the U.S. except on very rare occasions. From a theoretical viewpoint, such lists are excellent reference materials but they do not solve the need of the novice. At times like this, he would like to be able to inspect the logs of an experienced UM, to see what actually may be heard.

Enter the *Shortwave Log* by the well-known UM Fred Osterman. This is a detailed and extremely well organized compilation of loggings heard by the author over his listening career. Fred recognized the need for a listing of stations that can be heard by the average listener. For the beginning UM, this will be of considerable assistance in determining the origin of signals received. The *Shortwave Log* is not designed to replace the many fine frequency listings available; rather, it is intended to help the beginner make better identifications of what he has heard. This publication stresses utilities monitoring, including CW and RTTY. For those who are interested in Antarctic and Soviet stations, this book is the best I have used.

The book is broken down into three main sections. Loggings are listed by frequency, time, and country. In this way, specific stations may be hunted at the most favorable times and if your interests are in a particular country, its loggings are listed together. In addition, a spectrum analysis of all loggings with respect to frequency is included. There are, indeed, "dead air" spaces where extensive monitoring is not fruitful. Hot spots are also noted, allowing the newcomer to spend his listening time more beneficially. The *Shortwave Log* has a prominent place on my shelf and I would recommend it to anyone, novice or old-timer. The *Shortwave Log* is available from Universal Shortwave Radio Research, 1280 Aida Drive, Reynoldsburg, OH 43068.

### From The Mailbag

Kevin Busse of Minnesota writes to tell us of a recent and rather puzzling logging on 7750 kHz. At 0340 he monitored a series of random tones that were produced electronically, as in a video game. There were ten different tones, which were repeated continuously. At 0352 the tones ended and were replaced by very rapidly keyed numbers in the SSB mode. The CW numbers lasted exactly three minutes and were then replaced by the tones. The tones would repeat for about ten minutes and the CW would resume, with the message changing approximately every hour and a half. The signal strength was high, so he contacted the FCC monitoring station in Grand Island, Nebraska and requested the monitor to listen for it. Kevin says that the signal had the characteristics of some kind of beacon. In a letter, the FCC Engineer states that it is probably some type of weather or ocean sensor. This frequency is authorized for this purpose by about 40 different countries. Can any of our readers shed any additional light on this?

Tony Oreluk of Pennsylvania writes concerning a dramatic incident he monitored on 3789 kHz. At 0451, hams were in contact

with a boat 240 miles off the East coast. The craft had suffered a fire in the engine room and reported a hole in the side just above the waterline. Three crew members were injured and the craft required immediate assistance. The radio aboard the boat was running on battery power so their transmissions were very weak. Then, confused reports came regarding small arms fire. Later, the Coast Guard came on the frequency and Tony was able to put the situation together. Apparently, another craft had come within 50 yards of the disabled boat and fired upon it for no reason. The Coast Guard had dispatched two rescue vessels which had not appeared on the scene when the band gave out. I guess this is a story with a cliff-hanger because no other information was available. The amateur bands are always interesting places to monitor. Hams have always been ready to lend a hand when someone is in trouble. Thanks for the letter, Tony.

### How To Submit Your Loggings

Each month this column receives a tremendous amount of very welcome mail, much of it listening reports sent by our readers. These reports represent many hours of listening time for each sender and are generally quite interesting and well written. This column is for the reader and in it, we try to include as much material of general interest as space will allow. This goes for the loggings as well. Every effort is made to print well documented loggings of interest to the majority of readers. Sad to say, each month a number of very interesting reports cannot be included because they are lacking in some part of vital information. I would like to suggest a simple format for your loggings that will insure that all pertinent information is supplied. In this way, we can all benefit more from the listening reports section of Communications Confidential.

Obviously, some types of transmissions do not lend themselves well to a generalized form, callsigns for numbers stations being a superb example. However, if the bulk of the information listed below is supplied, the report is considerably more valuable to the other readers. A form need not be used. Just try to include the information listed.

- Date . . . . . (in GMT)
- Frequency . . . . . (kHz)
- Mode . . . . . (AM, CW, SSB etc.)
- Time on . . . . . (GMT)
- Time off . . . . . (GMT)
- Signal strength . . . . . (SINPO or S-Units)
- Content . . . . . (a general description of what you heard)
- Callsign . . . . . (if available)
- Country . . . . . (or language)

If you wish your name to appear, let me know. Otherwise you will assume the pen name of A. Anonymous. Send your loggings to Ron Ricketts, Communications Confidential, Box 795, Bedford, TX 76021. If you have questions you would like answered, be certain to include an SASE.

### Listening Reports

**570:** Time ticks in AM at 0400, various dates. Each min-

ute, a tone, one second of silence and the characters "RR" in CW. When compared to WWV, the tone was on the 12th second and the "RR" began on the 14th. (Jeffrey E. Hollis, WV) This is an interesting logging, Jeffrey. I would normally put this down to receiver problems except for the fact that several others have reported the same type of signals. They appear to be some kind of beacon and usually identify each minute in CW. Do any of you readers know what this might be? (Editor)

- 3177:** Unidentified station sending five-letter groups in CW at 0645. (Robert Margolis, IL)
- 3380:** WGY908, FEMA, Denver, CO sending encoded messages in CW at 0530. Each message contained six groups of five letters and were repeated seven times. (Robert Margolis, IL)
- 4050:** Female with young voice reciting 5-digit Spanish groups in AM at 0203. (Thad Adamaszek, OH)
- 4125:** At 0230 in AM, 5-digit Spanish numbers spoken by female announcer. "Atencion 044 45" repeated before message. Message ended with "final" at 0237. (Harold S. Easley, MD)
- 4174:** CW marker "DE GKB 4" repeated over and over at 0326. (Marc A. Mugmon, MD)
- 4265:** CW marker, "VVV DE CKN," Royal Canadian Navy, Aldergrove, BC. (Cliff Laidlaw, NY)
- 4380:** Unidentified station sending five-letter groups in CW at 0150. (Robert Margolis, IL)
- 4470:** WAR46 working CLEAN CUT on SSB at 0516. WAR46 is the callsign of the FEMA VIP Support Group facility at Ft. Richie, MD. (Robert Margolis, IL)
- 4580:** Civil Air Patrol traffic in USB at 1150. Text advised of notification of Sheriff's departments regarding a potentially downed aircraft. (Kenneth J. Navarre, Jr., CA)
- 4614:** CW marker "VVV VVV VVV DE IDR2." Very strong signal. (Marc A. Mugmon, MD) This is Rome Naval Radio. (Editor)
- 4670:** Female repeating with 4-digit groups, standard format at 0200. At 0300, "grupo 205" followed by 4-digit Spanish groups. XLE2 was audible in background during entire transmission. (Thad Adamaszek, OH) Female in AM with "Grupo 1-4-9" followed by 4-digit groups in Spanish at 0307. (Thad Adamaszek, OH) Four-digit Spanish numbers station with female announcer at 0200. Ran for 40 minutes, with repeat of the groups, and was a simulcast with 5812. At 0300, the same woman read a different numbers list until 0345 with repeat, but was not simulcast. (Robert Margolis, IL)
- 4780:** At 1130 in SSB, female with call of K9P calling P60, P1R, and P88. Sounded like U.S. military. (Harold S. Easley, MD)
- 4781:** Unidentified station sending five-letter groups in CW at various early-morning hours on various days. Each list always consisted of six groups and were repeated eight times. (Robert Margolis, IL)
- 4785:** 5-digit Spanish numbers station in AM with female announcer. (Cliff Laidlaw, NY)
- 5015:** At 0000 in AM, 5-digit groups in German spoken by female announcer. Transmission began with "Alpha November" followed by flute-like tones. Message began at 0005, ending with a tone at 0015. Audio with heavy bass and hollow sounding; hard to copy. (Harold S. Easley, MD)
- 5412:** At 0300 in AM, 5-digit numbers spoken in English by female announcer. "1234567890 352 352 352" repeated until 0310 then tone pulses followed by several messages. 3/2 rhythm, except that occasionally changes to 2/3. RTTY QRM from 0318 to 0352. The groups were very precisely timed with exactly 12 groups per minute. (Harold S. Easley, MD) A very good logging. Harold. There are not very many English spies, and I have not heard any on this frequency. (Editor)
- 5550:** Scrambled voice transmissions, short and repetitive in USB at 1112. Unable to decode by inversion methods. (Kenneth J. Navarre, Jr., CA) Listeners are going to be hearing a lot more of these as the military and other federal authorities go to this technique. These transmissions are digitized real-time and then encrypted prior to transmission. The receiving party then does an A-D (analog to digital) conversion, decrypts the data, and reassembles it into audio. The entire process takes about a half-second and is secure in the extreme. However, the signals must be relatively noise-free to be received properly. If any of you readers figure out how to break this, drop me a line. (Editor)
- 5598:** German Air Force 5096 working Gander, Newfoundland Aeradio in SSB at 0509. (Robert Margolis, IL)
- 5641:** At 0034 in AM, female repeating four words until 0036, when carrier dropped. Language was not identified. (Harold S. Easley, MD)
- 5696:** Coast Guard Rescue ships 1433 and 1501 on



SSB at 0701 working NMN, Coast Guard station, Portsmouth, VA as they searched the Atlantic Ocean for more than an hour for a 50-foot schooner in distress. The distress call was later determined to be a hoax. (Robert Margolis, IL)

**5790:** Unidentified station sending five-letter groups in rapid CW at 0415. (Robert Margolis, IL)

**5810:** Female in AM with "grupo 1-8-4" then 4-digit Spanish groups at 0200. (Thad Adamaszek, OH)

**5812:** At 0216 in AM, 4-digit Spanish groups spoken by female announcer. Message ended at 0236, carrier off at 0258. Flapping sound at end of message like a tape running loose. Low 60 Hz modulation on carrier. The fact that this station has a 60 Hz power narrows down its location. I suggest that monitors measure the frequency of any hum on the carriers. (Harold S. Easley, MD)

**5869:** Coded groups in CW, mostly 5 characters with 3 or 4 letters and 1 or 2 numbers at 0344. (Marc A. Mugmon, MD)

**5929:** Unidentified station with five-letter groups in CW at 0613. (Robert Margolis, IL)

**5985:** Five-digit Spanish numbers station with female announcer at 1000. The transmission was barely audible and was being clobbered with heavy QRM. (Robert Margolis, IL)

At 1003 in AM, 5-digit Spanish groups spoken by female announcer. "Atencion 022 35" repeated until message began. Finished with "Final, Final" at 1006. Carrier remained on and the previous transmission was repeated at 1030. "Final, Final" at 1036, carrier off at 1037. (Harold E. Easley, MD)

**6100:** Observatorio Naval Cagigal, Caracas, Venezuela. Time signal station with Spanish language ID every minute. (Keith Hill, NY)

**6515:** Woman reading traffic list on SSB at 0200 for VAF, Canadian Coast Guard, Albert Bay, British Columbia. (Robert Margolis, IL)

**6570:** At 0130 in AM, 5-digit Spanish numbers spoken by female announcer. Very hard to copy because of electrical storm. Carrier off at 0137. (Harold S. Easley, MD)

**6604:** Gander Radio with weather reports for Canadian locations in USB at 0321. (Marc A. Mugmon, MD)

**6728:** "Joyce 93" calling, mentions Wright Army Airfield. (Julie Burke, AK) Welcome to the column, Julie. (Editor)

**6761:** "Dilly 21," "Tertiary," "Organize," "Trumpet," "Sing Song," "Stalag," "Chip Shot," "Measly," and "Sultan" heard working this frequency at various times. The USAF is known for its colorful tactical call signs. All in SSB. (Robert Margolis, IL)

Jamming of this frequency by a man speaking Chinese and playing rock and Oriental music. This was on SSB at 0222 and was not found on AM. The man counted from one to five and back to one in German, French, English, and Chinese. This occurred during SAC's Global Shield 84 Exercise. Unknown location but in the U.S. because of a 20 dB reading. (Robert Margolis, IL) Good logging. If anyone wants to do some challenging DF work with a purpose, how about locating the SAC jammers? (Editor)

**6770:** Five-digit Spanish numbers station with female announcer at 0704. (Robert Margolis, IL)

**6775:** Five-digit Spanish numbers station with female announcer at 0606. (Robert Margolis, IL)

**6800:** Female in AM speaking 4-digit Spanish numbers at 0200. This transmission paralleled at 9075. (Thad Adamaszek, OH) Four-digit Spanish numbers station with female announcer at 0430. (Robert Margolis, IL)

**6802:** Four-digit Spanish numbers station with female announcer with simulcast on 5812 at 0400. (Robert Margolis, IL) At 0200 in AM, a Spanish speaking female transmitted a message consisting of a 3-digit group repeated three times followed by a 10-digit group. Very heavy QRM and weak signal. It would take a Spanish speaking person to retrieve this message. (Harold S. Easley, MD)

**6834:** 5KK, unknown location, sending a CQ marker in CW at 0500. (Robert Margolis, IL)

**6835:** Five-digit Spanish numbers station with female announcer at 0908. (Robert Margolis, IL)

**6840:** Hum and light pulse over Daventry SSB at 0230 then female in AM with numbers "9185-5711-9755-2336" over and over. Announcer was same female as usual 4-digit transmission on this frequency. (Thad Adamaszek, OH) At 0247 male in SSB counting to 100 in Spanish then "oro-oro-oro-oro." This was followed by more numbers, then three beeps and off at 0248. At 0250 more "oro's" followed by two-way talk. (Thad Adamaszek, OH) On another date, the digits "6033-2327-6872-8584-1288" were repeated over and over. This pattern of 4-digits was repeated various dates

around 0230. (Thad Adamaszek, OH) This is very interesting, Thad. There have been some very unusual transmissions here over the last few months. (Editor)

Four-digit Spanish numbers station with female announcer at 0230. The transmission began promptly with reading of the numbers groups without any sign-on. After a repeat of the lists, the transmission ended at 0240 with no "final" or "fin" sign-off. (Robert Margolis, IL)

**6860:** Unidentified station with five-letter groups in CW at 0125. Used letters ABDEINSTUV as substitutes for numbers and had NNNNN between each message. (Robert Margolis, IL) This is another version of "cut" CW numbers. (Editor)

**6870:** "Guard Post" working DAL46 on SSB at 0650. This frequency is assigned to KDM50, FAA net control. (Robert Margolis, IL)

**6874:** At 0106 in AM, English speaking female repeating "383" until 0110. (Harold S. Easley, MD)

**6875:** Five-digit Spanish numbers station with female announcer at 0647. (Robert Margolis, IL)

**6895:** Five-digit Spanish numbers station with female announcer at 0500. Instead of "grupo," the woman used "uno uno cinco/tres cero," which was the message number and number of groups it contained. Transmissions began with "attention 794." Before the list was repeated at 0514, the woman said "tres cero" three times. (Robert Margolis, IL)

**6915:** At 0730 in AM, 5-digit numbers spoken by female. "Atencion 426 25" repeated before message. Message finished at 0735, carrier off at 0743. The transmitter had downward modulation. (Harold S. Easley, MD)

**6937:** "Cotton Ball" calling "Dirt Ball," and "Golf Ball" calling "Cotton Ball" with tactical messages on SSB at 0220. (Robert Margolis, IL)

**7370:** "Roger" calling "Grandma" in SSB at 0502. (Julie Burke, AK)

**7434:** Unidentified station with five-digit groups, with zero cut as "T," in CW at 0210. (Robert Margolis, IL)

**7435:** Female in AM reciting "atencion 7-2-7 1-1-0" over and over in Spanish, then in 5-digit groups at 0804. (Thad Adamaszek, OH)

**7525:** Female in AM at 0300 repeating "atencion 5-3-6 8-0" over and over in Spanish followed by 0303 by 5-digit groups. Heavy QRM during transmission. This transmission repeated at same time on two consecutive days. (Thad Adamaszek, OH) Good logging, Thad. It must have been an early summer rerun. (Editor)

**7529:** Five-digit Spanish numbers station with female announcer at 0305. (Robert Margolis, IL)

**7627:** At 2312 in CW, "QRA QRA QRA DE KWS78 KWS78 KWS78 QSX 3/4/7/10/14 K." (Harold S. Easley, MD)

**7654:** At 2318 in CW, "QRA QRA QRA DE KKN44 KKN44 KKN44 QSX 4/7/11/17/23 K." (Harold S. Easley, MD)

**7660:** CLN78, Havana, sending QRZ (Who is calling me?) to UJY2, Radio Kalingrad, USSR, in CW at 0150. (Robert Margolis, IL) Big brother is calling you! (Editor)

**7675:** Challenger Space Shuttle launch: Victor One Charlie gives "launch mark monitor" to Gull 13 of the USAF on SSB at 1152, 2 hours, 8 minutes before lift-off. (Robert Margolis, IL)

**7707:** Test slip from Radio Havana at 0225 in RTTY, 170/67. "RCC/HAVANA/CUBA TESTING TO ITT/WC/NY..." followed by foxes. (Marc A. Mugmon, MD)

**7750:** Random electronic tones in AM mode at 0340 running for 10 minutes followed by CW numbers in SSB for 3 minutes. Repeating from 0340 until after 0500. (Kevin D. Busse, NE)

**7845:** Spanish numbers station with female announcer at 0645. Repeated 2-2-3-5 in Spanish five times before transmission and carrier left the air. Reception conditions very good, with a SINPO of all fives. (T. E. Jones, OH)

**7855:** USCG San Francisco reading weather reports in SSB at 0510. (Julie Burke, AK)

**8559:** GKB, Portishead, England, changing its DE marker every two minutes in CW at 0715: "DE GKB 2," "DE GKB 3," "DE GKB 4," "DE GKB 5," "DE GKB 6." (Robert Margolis, IL)

**8694:** "CQ DE 4XO QSX 12C K" repeated in CW at 0311. (Marc A. Mugmon, MD)

**8711:** "DE WLO RTTY K" repeated over and over in CW, 0307. (Marc A. Mugmon, MD)

**8778:** Skyking broadcast in USB at 0509 on Whiskey 7 Victor terminated after several unusually long coded transmissions. (Kenneth J. Navarre, Jr., CA)

**8972:** Five-digit Spanish numbers spoken by female at 0705, ending at 0708. (Julie Burke, AK)

**8990:** SAM 24127 in contact with MAC 59400 re-

questing they relay message to McClellan AFB, who instructed them to QSY to 4746, in SSB at 0755. (Julie Burke, AK) Also phone patch traffic to Hickham. (Julie Burke, AK)

**9006:** Trenton Military, Trenton, Ontario with radio checks at 2230. (Kevin D. Busse, NE)

**9042:** German language numbers station with female announcer in USB at 2340. (Gregory Majewski, CT)

**9050:** German 5-digit groups spoken by female announcer at 0202. Female has noticeable Eastern European accent. Also similar transmissions at 0300. (Thad Adamaszek, OH) Female with heavy Eastern European accent speaking 5-digit English groups at 0106. (Thad Adamaszek, OH)

**9075:** Female reciting "5-4-5" in Spanish under grinding noise in AM at 0100. (Thad Adamaszek, OH) Female in AM with 4-digit Spanish numbers at 0100—"grupo 196." (Thad Adamaszek, OH) Female in AM with Spanish numbers in 4-digit groups at 0023. (Thad Adamaszek, OH)

**9180:** The Mad Violin playing Hungarian(?) folk tune at 0100 followed at 0103 by male saying "terminat" three times. The music repeated again followed by "terminat" three times as before. (Thad Adamaszek, OH) A super logging, Thad! I have heard tapes of this and it is not quite believable. The violin is being played about three times faster than is humanly possible and somehow the orchestral accompaniment seems to keep up—barely. The messages being transmitted, if any, are imbedded in the violin music or perhaps might be in the order the tunes are played. The Mad Violin is a very rare catch and is well worth listening for. He has appeared on this frequency before. (Editor)

**9225:** Female reciting 4-digit Spanish groups in AM at 0100, usual format. (Thad Adamaszek, OH)

**9265:** Female with Eastern European accent with "group 2-7" followed by 5-digit English numbers at 0300 in AM. (Thad Adamaszek, OH)

**9380:** Female in AM reciting 5-digit groups in Spanish at 0303. "Final" at 0305. (Thad Adamaszek, OH)

**9445:** Young sounding female announcer with "atencion—502-25" followed by 5-digit groups at 0300. Noted strange buzzsaw type QRM at 0306. (Thad Adamaszek, OH)

**9560:** Female reciting 5-digit Spanish groups in AM at 0100. (Thad Adamaszek, OH)

**10000:** Military (?) traffic over WWV consisting of someone with the call sign RJH71 calling F3J61, A2D11, and A6T91 in SSB from 0120 to 0131. (Jamie Dowdy, IN)

**10295:** INTERPOL: CSJ25, Lisbon, Portugal sending cannabis smuggling traffic in Portuguese, and ONA20, Brussels, Belgium, with wanted assassin traffic in French at 1716. Transmissions were via SITOP. (Robert Margolis, IL)

**10355:** Unidentified station sending 5-digit groups with zero cut as "T" on CW at 0336. (Robert Margolis, IL)

**10493:** FEMA; WGY903, Olney, MD, working as "net control" while giving radio checks to WGY904, Thomasville, GA; WGY906, Denton, TX; WGY908, Denver, CO; WGY909, Santa Rosa, CA; WGY910, Bothell, WA; and WGY912, special facility at Mt. Weather. (Robert Margolis, IL) Very good logging, Robert. I am curious to know how you got the info on WGY912? (Editor)

**10780:** Bloodhound 36 of the USAF calling Victor One Charlie on SSB at 0507. (Robert Margolis, IL)

**10784:** Unidentified station with five-digit groups, with zero cut as "T," in CW at 0330. (Robert Margolis, IL)

**11039:** DDH37, Pinneburg, West Germany, sending weather forecasts in German in CW at 2113. (Robert Margolis, IL)

**11182:** Century 28, Yazoo 19, and Music 246 working SSB with Scott AFB, IL at various times. (Robert Margolis, IL)

**11200:** Station MVB giving Royal Air Force VOLMET information using SSB at 2242. (Gregory Majewski, CT)

**11261:** "D6P" calling "HOK" and "R3B" in SSB at 0845. (Julie Burke, AK)

**11270:** Male with American accent identifying himself as "4KN" calling "any station this net." He received no replies after several calls and signed off. In USB at 0319. (Marc A. Mugmon, MD)

**11284:** "TSM" sending 4-digit traffic in CW at 2056. (Robert Margolis, IL)

**11490:** Four-digit Spanish numbers station with female announcer at 1830, with the same groups being read on two consecutive days. (Robert Margolis, IL)

**12135:** NAM, USN, Norfolk, VA relaying CW information on torpedo firing exercises and submarine operations in Aegean Sea at 1640. (Robert Margolis, IL)



**12705:** WLO, Mobile Radio, AL, sending first-aid instructions for those injured fighting electrical fires. Was in CW at 1930. (Robert Margolis, IL)

**13354:** Czechans 238 working San Francisco Aeradio on SSB at 2343. (Robert Margolis, IL)

**13630:** KDM50, FAA, Hampton, GA and November 19 working Rockwell Flight Test on SSB at 1946. (Robert Margolis, IL)

**13767:** Five-alphanumeric-group messages, that included punctuation, sent in CW at 1814. The same 100 group message was repeated several times. (Robert Margolis, IL)

**13773:** Five-digit German numbers station with female announcer at 1747. (Robert Margolis, IL)

**13922:** CW letters station tracked down at 2105. (Gregory Majewski, CT)

**14443:** Repetitions of "KMT DE 70C 70C 70C" in RTTY, 170/67 at 0255. (Marc A. Mugmon, MD)

**14477:** Stations with NNØ prefix placing phone calls through a coastal station at 2330. (Kevin D. Busse, NE)

**14612:** YBU sending test slips "YBU YBU YBU 464646 . . ." 425 shift at 50 baud at 2300. This followed by 5 character groups. Signal is very strong. Prefix indicates Venezuela but no other information is listed. (Harry A. Weber, IL)

**14852:** Very slow CW, about 2 wpm, at 2307. Six code groups preceded by the figure "\$." Each group consisted of 5 letters and comprises one line. Each line is repeated five times. Example: "\$ LUOFX TPRXZ AXQEH THQOE ERVHB VWIHH." (Kenneth J. Navarre, Jr., CA) This is a new one on me. Do any readers know what this might be? (Editor)

**15963:** YBU sending two sheets of five-letter groups and one sheet of five-digit groups via RTTY, 425/67N, at 2047. (Robert Margolis, IL) This is an interesting logging. It appears that AME3 has faded into obscurity only to be replaced by YBU. Though the call indicates an Indonesian origin, signal strengths indicate this to be incorrect. This callign bears watching. (Editor)

**16458:** YBU sending 5-digit and 5-letter traffic via RTTY, 425/67R, at 2206. (Robert Margolis, IL)

**17432:** German language numbers station with female announcer in USB at 2118. (Gregory Majewski, CT)

**17975:** Sunny 11 calling Allotment and Repossess calling Chairman 12 at various times on SSB. (Robert

Margolis, IL)

**18005:** Red Breast working Valhalla on SSB at 2100. (Robert Margolis, IL)

**18680:** Five-digit Spanish numbers in AM with male announcer, sounded "live." Began at 1510 and ended at 1530 with "387-387-00000." (Joe Goetz, OH)

**20053:** Phone patch traffic in LSB at 2242 from a C-135B through Andrews AFB. Mission identified as SAM24126. Location given was "... somewhere over South America." (Kenneth J. Navarre, Jr., CA)

**20618:** Five-digit group messages to GMN occur quite regularly in CW at 1830. GMN is not the callign of a British station, but one adopted by a clandestine organization. (Robert Margolis, IL)

**20622:** 5KM, Bogota Naval Radio, Colombia, sending RTTY traffic in Spanish to the navies of Peru, Brazil, Ecuador, Argentina, Uruguay, and Bolivia at 1905, 425/100R. (Robert Margolis, IL)

**20823:** Five-digit group CW traffic in operations simulated to that on 20618. Transmission times are between 1900 and 2400, and CLP1, Havana, has been found to use this frequency for 5-digit and 5 letter traffic using CW or RTTY, 425/66N. (Robert Margolis, IL)

**21752:** At 1705 in CW, "VN N6NDBA" repeated until 1720 when it changed to "NB AD4TDB." (Harold S. Easley, MD) This is another example of "cut" CW, where 1 through 0 correspond to AUV4E 6BDNT. (Editor)

**22068:** Five-letter groups being sent by CCS, Chilean Navy, Santiago, to "HU." Was in RTTY, 850/66N, at 1912. (Robert Margolis, IL)

**25229:** Sounds of what appeared to be data bursts. About 14 seconds between each burst and bursts would last from fractions of a second to up to two seconds. The bursts seemed like pulse waves rising in pitch. (Robert Margolis, IL) Robert, though you didn't mention the time of day, if the bursts sounded somewhat like the waves breaking over a beach, you may have been hearing the planet Jupiter. In times of lowered sunspot activity, when Jupiter has risen, it transmits wideband noise patterns sounding remarkably like the surf. This is generally noted on frequencies in this area, but have been heard as low as 18 MHz. When conditions are good, these signals are quite strong. I have personally monitored strengths in excess of 20 dB. If this is what you heard, then you had some REAL DX. (Editor)

**TOTALLY AWESOME!**



Exotic and functional gear. Genuine military clothing for outdoors, survival and the street. Best quality at the right price. Satisfaction guaranteed. Send \$3.00 for your full year subscription to our color mail order catalog.

**U.S. CAVALRY**  
WORLD'S FINEST MILITARY EQUIPMENT

1375 N WILSON RD. RADCLIFF, KY 40160 (502) 351-1164

Please send all reader inquiries directly.

**Free Catalog Features  
Hard-To-Find Electronic  
Tools**



Page after page of hard-to-find electronic tools and test equipment. Also contains a complete line of tool kits and tool cases. Send for your free copy today!

**JENSEN TOOLS INC.**  
7815 S. 46th St. Phoenix, AZ 85040  
(602) 968-6241

CIRCLE 20 ON READER SERVICE CARD

**3 GOOD NAMES TO BUY FROM US  
AND 3 GOOD REASONS WHY...  
QUALITY, VALUE, & SERVICE**

**Regency**

MX3000 Scanner	\$179.95
Z10 Scanner	\$139.00
R-106 Scanner	\$88.95
C403 Scanner	\$54.95
HX650 Scanner	\$72.50



**HX650**

**Cobra**

Command Call, Model HC-200	\$34.95 Each
Radar Detectors, Model RD-3000	\$99.00
Model RD-4000	\$137.95

**Bearcot**

210XL Scanner	\$213.00
201 Automatic Scanning Radio	\$184.00
180 Scanner	\$152.55
5 Crystal Scanner	\$86.95
Five-Six Portable Scanner	\$119.95
100 Scanner	Ask for Our Discount Price



**SPARTAN SUPPLY CO., INC.**  
P.O. Box 310 Hixson, TN 37343  
Call Toll Free 1-800-251-3904

We accept VISA, MasterCard, C.O.D., or pre-paid orders (cashiers or certified checks; personal checks held for clearance). Add \$3.25 service charge to each order. Include sufficient shipping; any overage will be refunded. All orders shipped UPS unless otherwise requested. Spartan Supply Company is not responsible for typographical errors.

VISA MasterCard

**Introducing  
15,999 channels  
that fit in  
the palm of  
your hand**

**THE RX-40 SERIES  
SYNTHESIZED  
VHF/FM RECEIVERS**



**OUTSTANDING FEATURES:**

- Full coverage of VHF band between 141-180Mhz or 131-170Mhz with a state-of-the-art PLL synthesized circuitry.
- 800 (15,999) selectable channels in 2.5Khz steps by digital thumb-wheel switches.
- Adjustable squelch level to eliminate background noise on FM mode.
- Extremely low battery consumption providing more than 10-hours operation.
- Compact pocket portable with lightweight aluminum case.
- Supplied with flex rubber antenna, Ni-Cd battery pack and AC charger.

**FOR MORE INFORMATION WRITE OR CALL** Executive Suite 108  
Deco Towers  
330 West 42nd Street  
New York, NY 10036  
(212) 245-3331

**ESCO**



# RADAR REFLECTIONS

## RADAR DETECTORS AND THEIR USE

BY JANICE LEE

### **Georgia State Patrol Faces Challenge In The Use Of Radar**

An appeal challenging the use of radar by the Georgia State Patrol in issuing speeding tickets has been filed in the Georgia Supreme Court.

"This is going to be a major case involving unfair and unjust use of radars in Georgia with a law that we see as being unconstitutional," DeKalb County lawyer Jim Lewis said recently. "This law puts the state above the law. It makes allowances for the state patrol when using radar to issue tickets, but not for municipal or county police."

State patrolmen do not have to show the person who is ticketed that his speed detection device is working properly, while city and county officers must, he said. Also unlike city and county police, state patrolmen are allowed to issue tickets in areas where no warning signs are posted.

Lewis has appealed to a Cobb County state court ruling in the case of his client, John Minnick Pfautz of Atlanta. Pfautz is challenging a \$109 speeding ticket he received from a state patrolman on Interstate 285 in Cobb County after he was allegedly clocked at 76 mph in a 55 mph zone.

State Court Judge Associate Mary Staley ruled against Lewis motion to suppress the patrolman's testimony of what the radar read at the time the ticket was issued against his client because "there would be no way to contest it."

### **Speeding Signs Mean Exactly What They Say**

Four attention-getting signs are Wright-Patterson Air Force Base's latest weapon to combat speeding on the ground. Below four "Speed Limit 30" signs, traffic officials have posted signs that say "30 means 30." Traffic officials expect the result to be a decline in speeding ticket—at least temporarily.

"Our base commander (Leonard Peterson) did this at Andrews Air Force Base in Maryland. It had some effect there," said Jeff Lindley, a traffic engineer at the base. "We put up four of those signs in locations where we've had a problem in the past with people speeding. The idea is you'll look at a sign like that, you'll notice it and hopefully you'll be thinking about it."

"It's possible the reason it does work is it's a novel thing. People will say 'hey, that's a dumb sign,' but maybe they'll slow down," Lindley further commented.

"We haven't really had a chance to evaluate it," but so far, the signs are at least a conversation piece, Lindley remarked. "The big comment is 'What are you trying to do with these things?'"

How long the signs stay up depends on whether there's a reduction in the number of speeding tickets, according to Lindley. If the signs aren't stolen, they could last 10 or 15 years, although they're not likely to stay up that long.

### **Radar Equipment Validated, Judge Will Try Speeding Cases**

About 200 pending Municipal Court cases for speeding violations in Waterford, New Jersey will be heard individually because police have convinced the judge their radar equipment could be tested and operated properly.

Municipal Court Judge Angelo DiCamillo threatened to dismiss all of the cases because of questions about the radar equipment.

After reviewing documents submitted by township police, however, he ruled that each speeding case will be tried on its individual merits.

DiCamillo's decision came after township prosecutor Nicholas F. Trabosh presented a looseleaf binder with police certification for the past five years.

"The judge made a request for the records when he saw a potential problem," Trabosh said later.

At issue was whether the police had certified tuning forks for testing the accuracy of their radar equipment. Police are supposed to have a pair of tuning forks to test radar at 35 miles per hour and 80 miles per hour. The radar is supposed to be checked at the beginning of each shift.

Trabosh said records presented to the judge showed that a pair of tuning forks were reported missing by detectives last January. But that same month, the police department certified a second pair of tuning forks that they had kept in storage for at least three years. The pair of \$3.50 tuning forks were certified January 11 with the state Superintendent of Weights and Measures in Trenton.

DiCamillo was concerned about the legitimacy of 200 cases which dated from October 29, 1981 to January 11 of this year after a police officer testified that a tuning fork was misplaced last fall.

Another reason for concern was that an officer was suspended without pay for two weeks last March for lying in court that his radar equipment was improperly calibrated. The officer, Gayle Travis, was questioned by an assistant Camden County prosecutor investigating allegations of ticket fixing.

Travis told the prosecutor that he lied to a judge not to fix a ticket but to retaliate at his supervisor over a policy requiring police officers to write a minimum of tickets per month.

Public Safety Director John Rauscher denied that a quota system for speeding tickets exists.

Fines in the 200 pending speeding cases range from \$60 to \$100. The township could have lost thousands of dollars in fines if a large number of those cases had been dismissed.

### **Florida Highway Patrol Gets More \$\$\$ To Stop Speeders**

The state of Florida recently received its sixth annual allocation from the National Highway Traffic Safety Administration for the "Intensified Speed Law Enforcement Program," which steps up the speed limit enforcement during the summer, according to Capt. Clyde Pfeiffer, the highway patrol's information officer in Tallahassee.

More than 56,000 traffic tickets were issued by the FHP with the help of last year's grant, which amounted to about \$750,000, according to highway patrol records.

As many as 250 new radar and vascar units will be purchased for highway patrol vehicles this year with the new grant, according to Jim Sewell, the state Division of Highway Safety's director of management and planning services.

Of the 56,000 traffic tickets issued by highway patrol officers during last year's target period, 49,000 were for speeding violations. The other 7,000 tickets were for miscellaneous infractions, highway patrol records show.

### **Three Drivers Lose Radar Battle—But May Get Second Chance**

Three King County, Washington residents were told recently that they will have to wait until they again get speeding tickets before challenging the use of radar by Seattle police.

The state Court of Appeals rejected their claim that the city should be enjoined from using radar for traffic enforcement because of allegations that the equipment isn't reliable and the operators are unqualified.

John W. Orwick, Arthur M. Peterson, and John A. French were stopped separately by police a few years ago, cited for speeding, and scheduled for contested hearings in Municipal Court. Before going to trial, however, they filed suit against the city in King County Superior Court. They asked the court to declare use of radar unlawful and to enjoin the city from issuing any further traffic infraction notices based on use of the devices.

The court was asked to block the use of devices until the city instituted training programs for its radar operators and a procedure was set up to convince the court that

radar readings of vehicle speed are reliable.

The city got the case thrown out of Superior Court late in 1981 on jurisdictional grounds. A Superior Court judge ruled the dispute would have to be heard in Municipal Court.

Orwick, Peterson, and French appealed that decision, and the matter languished in court until late last month.

The appeals court said they could have contested the accuracy of radar when they went to trial in Municipal Court. The three-judge panel said Superior Court was the wrong place to wage their fight.

That decision left the three men in an unusual situation. They no longer can press the matter in Municipal Court because the original speeding charges were dismissed during the lengthy delay.

The city successfully moved to dismiss the cases before they went to trial. It was a move that allowed the city to claim the whole matter was moot and shouldn't take up any more time in any court.

If Orwick, Peterson, and French want to continue the battle with radar, they have two choices. They can appeal the decision to the state Supreme Court or they can go get new speeding tickets. The appellate court said they could carry on their fight against radar "should they receive traffic infraction citations for speeding in the future."

## Hamilton County, Ohio To Put Radar Guns Away

Hamilton County Sheriff Lincoln Stokes thinks his deputies who work at night should spend their time looking for burglars rather than speeders. As a result, most county deputies assigned to road patrol between 11 p.m. and 7 a.m. have been ordered to stop using their radar units. The exception is deputies assigned to certain township communities on a contract basis. Radar is optional for those units.

Capt. Ray Hoffbauer, the officer in charge of the sheriff's road patrol, gave three reasons for the radar ban:

- Speeding during the night shift is not a big problem, but burglars are. The extra time spent by deputies in crime prevention should be more productive.
- Operating radar after dark can be dangerous to the officer who has to stop a car at night.
- The radar units were beginning to show wear, and maintaining them was proving too costly. The "rest" given the units should cut operating repair costs.

A spokesman for the sheriff's department said the no radar order will be evaluated after a two-month trial.

In addition, a check with several area police departments disclosed that most will wait and see how the county's plan works before trying it out themselves.

## Trooper Stops Elderly Speeder Going To Funeral

Idaho State Police Cpl. Bob Connor did not know what to expect when he caught up

with a driver who led him on a 28-mile chase at speeds of up to 90 mph near Twin Falls recently. But he said the last thing he expected was a 71-year-old man on his way to a funeral in California—headed in the wrong direction.

Connor said he was taking radar readings on Interstate 84 near Burley when a west-bound Cadillac zipped by at 90 mph. Connor turned on his car's lights and sirens and followed the Cadillac, whose driver apparently did not see or hear him, he said.

The trooper chased him for 16 miles and then was joined by a sheriff's car about 17 miles west of Burley.

Both cars pursued the Cadillac for 12 miles before a second state police car and second Jerome County car turned onto Interstate 84 ahead of the Cadillac and slowed it to a stop, Connor said. With guns drawn, the four officers arrested the 71-year-old Canyon City, Colorado resident.

"We were surprised," Connor said of the officers' reaction to the senior citizen. "But you never know; they come in all ages."

After being released from the Jerome County Jail, the senior citizen was back on the road—this time headed in the right direction.

"He was just in a hurry to get to California. He got mixed up and got lost," Connor said.

Janice Lee is the Editor of Monday, A.M., the newsletter of Electroret, Inc.



**7 MILLION TUBES FREE CATALOG**  
Includes all Current, Obsolete, Antique, Hard-To-Find Receiving, Broadcast, Industrial, Radio/TV types. **LOWEST PRICES**, Major Brands, In Stock.  
**UNITY Electronics Dept. P.C.**  
P.O. Box 213, Elizabeth, NJ 07206



CIRCLE 115 ON READER SERVICE CARD

**COMPUTER<sup>®</sup> TRADER MAGAZINE**

★ ★ ★ LIMITED TIME OFFER ★ ★ ★  
**BAKER'S DOZEN SPECIAL!**  
**\$12.00 for 13 Issues**

Regular Subscription \$15.00 Year  
Foreign Subscription: \$55.00 (air mail)  
\$35.00 (surface)

Articles on MOST Home Computers, HAM Radio, hardware & software reviews, programs, computer languages and construction, plus much more!!!  
Classified Ads for Computer & Ham Radio Equipment

**FREE CLASSIFIED ADS** for subscribers  
Excellent Display and Classified Ad Rates  
Full National Coverage

**CHET LAMBERT, W4WDR**  
1704 Sam Drive • Birmingham, AL 35235  
(205) 854-0271  
Sample Copy \$2.50

CIRCLE 58 ON READER SERVICE CARD

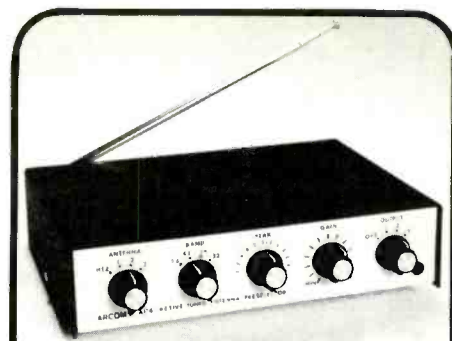

## The Best Active Antenna COSTS LESS!

The new ARCOMM AP4 active tuned antenna/preselector is the most versatile, best performing unit available. Ideal for use where outside antennas are not possible.

**89<sup>95</sup>**

including FREE AC adapter

### FEATURES:

- Tunes 540 KHz thru 32 MHz in four bands
- Improves RF selectivity and image response of any receiver
- Accepts up to four external antennas
- Internal telescoping antenna provides excellent results
- Switched output jacks provided for up to three receivers
- Operates on internal 9 volt battery (not included) or AC adapter
- AC adapter included at no extra cost
- Full twelve month limited warranty
- Ten day return privilege if not completely satisfied

To order, send check or money order plus \$3.00 shipping PA residents add 6% sales tax. Dealer inquiries invited

**ARCOMM**

24 Valley Street  
Lewistown, PA 17044  
(717) 248-7739

CIRCLE 71 ON READER SERVICE CARD

**AIRCRAFT - AIRPORT CAR RADIO!**

"LISTEN IN" TO AIRCRAFT - AIRPORTS - WORLDWIDE!  
118-136 Mhz. Works in cars or with ALL home radios - NO HOOKUPS NEEDED! Self powered - Works everywhere. Complete \$29.95 (plus \$2.00 post). Call 1-308-236-5333 ANYTIME with credit cards or order by mail. Same day shipment. Free Information.

WESTERN RADIO DEPT-C KEARNEY, NEBR. 68847



CIRCLE 30 ON READER SERVICE CARD

**AIRCRAFT MONITOR RECEIVER 116 - 140 MHz**

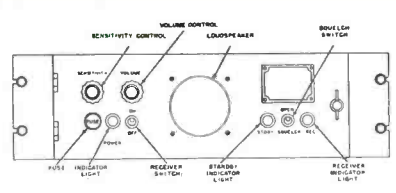

- Dual conversion, single channel, crystal controlled monitor receiver
- Completely reconditioned and set to desired frequency
- Maximum 5 watts audio output available
- Built-in loudspeaker may be used alone or with 4 or 600 ohm external audio output
- 117/230 VAC, 50-60 Hz power input
- Schematic included
- Please indicate desired operating frequency and input power voltage when ordering
- A relay can be connected to receive indicator light to run a tape recorder
- Price: \$75.00 each, less antenna.

N.E. Litsche  
P.O. Box 191 • Canandaigua, NY 14424  
716-394-0148

CIRCLE 38 ON READER SERVICE CARD



# WASHINGTON PULSE

## FCC ACTIONS AFFECTING COMMUNICATIONS

### **Licensees Denied Review Of Actions Dismissing Applications**

The Commission denied four Specialized Mobile Radio (SMR) licensees review of staff actions dismissing their applications for additional 800 MHz SMR frequencies.

The four licensees are Leascom Carrier Communications, operating WXW-958 out of Washington, D.C.; Carrier Communications Corporation, operating WZN-577 at New York City; Comtram Associates, operating WZF-972 out of New York City; and Big Rock Communications, operating WSB-605 from Los Gatos, California.

In 1982, the Commission released all remaining channels in the 806-821 and 851-866 MHz bands nationwide. November 15 to December 15, 1982, was set as the period during which applications for new frequencies would be accepted. In addition, no additional applications for frequencies would be accepted unless applicants had loaded their authorized frequencies to 90 percent of the prescribed minimum loading level. Since Leascom, Carrier, Comtram, and Big Rock had not satisfied these conditions, the Private Radio Bureau dismissed their applications.

In denying review, the Commission pointed out that the purpose in establishing the December 15 cut-off date was to eliminate waiting lists as a selection tool for new frequencies and freeze all cities so they could be treated equally. An advantage was given to fully loaded SMR operators by allowing them to apply for additional channels and, moreover, ruling they would have the highest number of comparative points at lottery time for the new frequencies. Therefore, the Commission said that in fairness to all SMR applicants nationwide, the applications of Leascom, Carrier, Comtram, and Big Rock must be dismissed.

### **Comments Invited On Issues To Be Addressed At 1987 Mobile WARC**

The Commission has begun an inquiry to solicit public comment on issues that should or should not be addressed by the 1987 World Administrative Radio Conference (WARC) for the Mobile Services. This information will help the FCC develop recommendations for U.S. proposals for the Conference. They also requested data on the past, current, and projected usage of the high frequency (HF) bands used by the Maritime Mobile Service.

The 1987 Mobile WARC is a direct result of the 1979 WARC, whose mandate was to revise the international radio regulations, as necessary. It is being convened to address the radio regulations pertaining to the mobile services that were addressed neither

by the 1979 WARC nor by the 1983 Mobile WARC, whose purview was limited to safety and distress matters.

This notice is the first of several in the conference preparatory process. The notices will be placed about six months apart with a report and order being issued in the latter part of 1986. U.S. proposals for the conference are due in Geneva in December 1986.

Other conference preparatory activities include an FCC intra-agency coordinating group chaired by the Office of Science and Technology, and an inter-agency ad hoc group.

This first notice, in addition to information on usage of the HF bands, requests comments on: the assignment of frequencies in the HF bands; the need for wide band telegraphy; problems and solutions that might result from sharing with the fixed service in the bands 4000-4063 kHz and 8100-8195 kHz; the use of various transmission modes within the same frequency bands; and ideas on how the new WARC 79 HF bands should be subdivided among the various operational maritime mobile user categories.

### **FCC Assists In Life Saving Incident**

FCC's monitoring net provided emergency radio direction-finding assistance in a recent lost aircraft incident.

The pilot of a French-registered private Cessna 206 was enroute from Pago Pago in the Samoan Islands to Hawaii when he became lost and began to run low on fuel. The air traffic control center in Honolulu contacted the monitoring station in Waipahu and requested direction-finding (DF) assistance, as the aircraft was not within radar range. FCC technicians provided two long range DF fixes.

With this information, two Coast Guard search and rescue aircraft were able to locate the plane and began to escort it to Honolulu. Ten miles short of land, the Cessna ran out of fuel and crashed into the ocean. At that time, a Coast Guard helicopter rescued the pilot, who had suffered a broken nose and bruises.

The monitoring net is manned 24-hours-a-day to provide assistance in these types of emergencies.

### **Applications For Shore Based Radionavigation Stations To Be Coordinated With Coast Guard**

On the request of the Coast Guard, the Commission amended its rules to require that applicants for shore-based radionavigation stations coordinate with the Coast Guard prior to submitting the application to the FCC.

This process will permit the Coast Guard to fulfill its statutory responsibility to ensure such private marine radionavigation aids do not pose a hazard to navigation. Prior coordination will allow prompt and efficient processing of the applications.

The Commission noted that stations used only for surveillance and not operated as an aid to navigation are considered radiolocation stations and do not require prior coordination with the Coast Guard.

### **Rules Governing Equipment In Maritime Mobile Service Denied**

The Commission upheld its decision to delete and simplify requirements governing spare parts, tools, test equipment, instruction books, and circuit diagrams for compulsory ship stations in the maritime mobile service, including the adoption on reconsideration of the suggestion of the American Institute of Merchant Shipping and others that the FCC substitute a list of required materials prepared by ship stations licensees in lieu of a list prepared by manufacturers.

It denied David B. Popkin reconsideration of adoption of this listing requirement.

Popkin asserted that licensees will construct their spare parts lists in such a way as to avoid failing a Commission inspection by omitting missing spare parts from the list. No facts or arguments were advanced beyond this bare assertion.

The FCC noted that the old system, whereby the Commission specified the spares, resulted in carriage of parts which often had no relation to the communications equipment actually aboard a particular vessel. That is the reason the Commission abandoned this approach.

It is said that while the new system did have a potential for abuse, the probability of this was low, in light of marketplace incentives which would encourage vessel operators to guard against failure of their communications system while at sea.

### **New Experimental Actions**

The FCC took the following actions:

KE2XNR, Michigan Technological University, L'Anse, Michigan. Experimental station to operate on 401.7130 MHz to collect data via GOES Satellite for use in fire/weather forecasting and water runoff prediction.

KO2XBG, Westinghouse Communication Services, Inc., Anne Arundel, Maryland. Experimental station to operate on various discrete frequencies between 8600 and 9900 MHz for development of equipment to be exported to the Republic of China.

KO2XBS, Datapoint Corp., San An-

tonio, Texas. Station to operate on discrete frequencies between 21,825 and 23,175 MHz to develop a full duplex radio capable of reliable transmission.

KO2XEA, Goodson And Associates, Inc., Johnson County, Kansas. Experimental station to operate on 10,525 and 24,150 MHz to develop new and better means both in range and range-rate using low power microwave devices.

KO2XEB, Meteor Communications Corp., Graham, Washington, and 1200 mile radius of Kent, Washington. Experimental station to operate on 46.18 and 49.40 MHz to develop a meteor burst communications service available to all users.

KO2XEC, E.I. du Pont de Nemours & Co., (Inc.), Camp Hill, Pennsylvania. Experimental station to operate on 30-1000 MHz band to measure the shielding effectiveness of shielded connector/cable assemblies in an open field test site to provide information of electromagnetic interference to customers regarding EMI cable emanating from computing devices.

KO2XEG, OKI Advanced Communications, Continental U.S. Experimental station to operate in 825-845 MHz band to confirm operation, improve on the present equipment, looking toward the development of equipment having practical utilization of spectrum-efficient communication system.

KO2XEH, Northern Telecom, Inc., Triangle Park, North Carolina and 25 mile radius. Experimental station to operate on 825-845 mobile and 870-890 MHz fixed bands to develop the software and hardware necessary for digital telephone switching-system to control the RF portion of a cellular system designed to meet the requirements of cellular service for smaller urban/rural locations.

KO2XEI, Teletech, Inc., Dearborn, Michigan and 20 mile radius. Experimental station to operate on 825-845 MHz (mobile) 870-890 MHz (fixed) to conduct research and development of techniques to further art and knowledge of Domestic Public Cellular Radio Service.

KO2XEM, Granger Associates, Within Continental U.S. Experimental station to operate on 928.8375 and 952.8375 MHz to field test collect measurement data and demonstrate concept of multi-point UHF radio.

KO2XEO, King Radio Corp., Olathe, Kansas and 100 mile radius. Experimental station to operate on 156-162.025 MHz band as contained in part 83 of FCC rules to test equipment prior to making application for type acceptance.

KO2XEP, Millidyne Services, Inc., Purnell, North Carolina and various counties. Experimental station to operate on 870-880 MHz (fixed) and 825-835 MHz (mobile) to make instrumentation tests on antennas and components to establish that they meet the requirements of cellular system being developed.

KO2XEQ, Millidyne Services, Inc., Knightdale, South Carolina and various

counties. All other information same as above.

KO2XER, Digital Microwave Corp., Continental U.S. Experimental station to make field strength surveys and/or equipment demonstrations for sales purposes on frequencies specified in Parts 21 and 94. Prior to activation of station licensees required to furnish technical information and obtain permission.

KO2XES, University of Illinois, The Board of Trustees of the, Wallops Island, Virginia. Experimental station to operate on 2224.750; 3385.000; 5040.000 kHz to support research in ionospheric radio propagation required by U.S. Gov't contract.

KO2XET, RCA Corp., Moorestown, New Jersey. Experimental station to operate on 3050 MHz to test a track-while-scan processor connected to a commercial S-band search radar.

KO2XEV, General Electric Radio Services, Corp., Dewitt, New York. Experimental station to operate on 5200-5700 MHz band. Using a low level noise modulated jamming transmitter to develop a digital beam-forming radar system.

KO2XEY, General Electric Radio Services Corp., 30 mile radius of Syracuse, New York. Experimental station on 5200-

5700 MHz band for use in development of a digital beam-forming radar system.

KO2XFA, General Railway Signal Company, within Continental U.S. Experimental station to operate on 906 MHz to develop automatic vehicle monitoring equipment to operate under Part 90.

KO2XFB, Grumman Aerospace Corp., 150 mile radius Binghamton, New Hampshire. Experimental station to operate on various discrete frequencies between 424.0 and 446.0 MHz to make system improvements so as to minimize degradation caused by man-made interference to E-2C system.

KO2XFC, Northeast FM Repeater Association, Brooklyn, New York and 63 mile radius. Experimental station on 902-928 MHz band for development of Amateur Radio Service in a new frequency band.

KO2XFD, Weber State College, Ogden, Utah. Experimental station on 450.0 MHz to control satellite and provide ground station for receiving telemetered data.

KO2XFE, Weber State College, a non-geostationary satellite. Experimental station to operate on 137.9 MHz to transmit only when commanded by the Ogden Utah station with maximum transmit time of nine minutes.

KO2XFF, Municipality Of Metropolitan

**May We Recommend**

**The Longwave Club of America, 45 Wildflower Rd., Levittown, PA 19057.** Here's a club for those rugged enthusiasts interested in knowing what's happening below 540 kHz! Their monthly publication, *The Low-down*, not only covers listings of stations operating between 10 and 540 kHz, but also has interesting coverage of the 1750 Meter (no license) low power communications band as conducted by Ken Cornell (W2IMB—well known "lowfer" authority. Membership includes mailing of the publication by First Class Mail and costs \$10 per year (anywhere in the world). When writing to the above, please mention that you saw it in POP'COMM!

**Channel Guard XL-1000**  
Adjustable Transmitter  
Low-pass filters & antenna tuner for CB & Ham use.  
Eliminates TV interference. Functions as an effective antenna tuner; 100 db rejection of spurious RF above 40 MHz; Has VARIABLE input impedance-50-70Ω. Handles up to 1 KW (SSB); Negligible insertion loss; Compact; Instructions \$35  
XL-500 - 500 watts-non tunable \$25  
XL-150 - 150 watts-non tunable \$15 MC & VISA  
**TELCO PRODUCTS CORP.**  
25 Lumber Road, Roslyn, NY 11576

CIRCLE 98 ON READER SERVICE CARD

**RADIO WORLD**  
Order Toll Free: 1-800-448-9338  
Your Source For Shortwave Receivers, Antennas, RTTY Converters, Computers, Interfaces And Scanners.  
Kenwood • Yaesu • Icom • Collins • Drake • Robot • Kantronics • AEA • Info-Tech • MFJ • Microlog • Grove • Commodore • Bearcat • Panasonic • Regency  
**HAM RADIO WORLD**  
Oneida County Airport • Terminal Building  
Oriskany, New York 13424  
1-315-736-0184

CIRCLE 56 ON READER SERVICE CARD

**MISSOURI RADIO CENTER**

uniden CR-2021 Portable

- Covers 150 KHz to 30MHz - AM, SSB, CW plus 88 to 108 MHz - FM
- Keyboard channel selection
- 12 Channel memory
- AC or DC operation

**\$89<sup>00</sup>**

**CALL FOR SPECIAL SALE PRICES**

**CALL TOLL FREE 1-800-821-7323**

2900 N.W. VIVION RD. KANSAS CITY, MISSOURI 64150

CIRCLE 145 ON READER SERVICE CARD



Seattle Central, Seattle, Washington and 6 mile radius. Experimental station to operate on 49.86 MHz to develop an automated location monitoring system.

### **Importers Need To Submit Statement To FCC Regarding Importation Of Certain Radio Frequency Devices**

Importers and brokers who bring radio frequency devices into the United States must report these devices on FCC Form 740. Some examples of radio frequency devices are:

- Radio and TV Receivers
- RF Converters
- Transmitters
- Transmitting Devices
- Cordless Telephones
- Radio Frequency Amplifiers
- Computers
- Microwave Ovens
- Industrial Heaters
- Ultrasonic Equipment
- Receiver Chassis
- Transmitter Chassis
- Transceivers

The purpose of the FCC Form 740 is to ensure that imported radio frequency devices meet the FCC's technical standards, thus minimizing the risk of harmful interference to existing radio services.

A Form 740 is to be sent to the FCC on or before the date the shipment is delivered in a U.S. port of entry. The mailing address is: Federal Communications Commission, Washington, D.C. 20554, Attention: Imports. A copy of the Form 740 must accompany the shipment.

To obtain copies of FCC Form 740, send a request to: Federal Communications Commission, Washington, D.C. 20554, Attention: B-10.

### **Amateur Radio Volunteer-Examiner Coordinators**

The Commission has executed a Memorandum of Agreement with the following entities to serve as Volunteer-Examiner Coordinators (VEC's) for the regions designated.

**Region 1:** Connecticut, Maine, Massachusetts, New Hampshire, Rhode Island, and Vermont: None.

**Region 2:** New Jersey and New York: Metroplex Amateur Radio Communications Association, P. O. Box 237, Leonia, New Jersey 07605.

**Region 3:** Delaware, District of Columbia, Maryland, and Pennsylvania: Laurel Amateur Radio Club, Inc., P. O. Box 3039, Laurel, Maryland 20708.

**Region 4:** Alabama, Florida, Georgia, Kentucky, North Carolina, South Carolina, Tennessee, and Virginia: Central Alabama VEC, 606 Tremont Street, Selma, Alabama 36701; and Western Carolina Amateur Radio Society VEC, P. O. Box 16189, Asheville, North Carolina 28816.

**Region 5:** Arkansas, Louisiana, Mississippi, New Mexico, Oklahoma, and Texas: Dallas Amateur Radio Club, Inc., P. O. Box 173, Dallas, Texas 75221.

**Region 6:** California: Greater Los Angeles Amateur Radio Group, c/o Steven L. Shafit, 21921 Lanark Street, #201, Canoga Park, California 91304; and San Diego County, Amateur Radio Council, Inc., P. O. Box 82642, San Diego, California 92138.

**Region 7:** Arizona, Idaho, Montana, Nevada, Oregon, Utah, Washington, and Wyoming: Boeing Employees Amateur Radio Society, P. O. Box 3707, Seattle, Washington 98124.

**Region 8:** Michigan, Ohio, and West Virginia: Dayton Amateur Radio Association, P. O. Box 44, Dayton, Ohio 45401.

**Region 9:** Illinois, Indiana, and Wisconsin: DeVry Amateur Radio Society, 3300 North Campbell Avenue, Chicago, Illinois 60618.

**Region 10:** Colorado, Iowa, Kansas, Minnesota, Missouri, Nebraska, North Dakota, and South Dakota: None.

**Region 11:** Alaska: Anchorage Amateur Radio Club, P. O. Box 101987, Anchorage, Alaska 99510-1987.

**Region 12:** Caribbean Insular Areas: Director, Military Affiliate Radio System, P. O. Box 7388, Cidra, Puerto Rico 00639.

**Region 13:** Pacific Insular Areas: None.

Qualified amateur radio operators who wish to volunteer their services as examiners should contact a VEC in their region. Volunteer Examiners are coordinated by VEC's.

An entity interested in serving as a VEC should apply in writing to the FCC, Personal Radio Branch, Federal Communications Commission, Washington, DC 20554. Approval to serve as a VEC is contained in a Memorandum of Agreement signed jointly by the VEC and the FCC.

Entities engaged in the manufacture or distribution of equipment used in connection with amateur radio transmissions, or in the preparation or distribution of any publication used in the preparation for obtaining amateur radio station operator licenses, may be VEC's only after submitting documentation to the FCC to show that preventative measures have been taken to preclude any possible conflict of interest.

A VEC must not discriminate in accrediting volunteer examiners on the basis of race, sex, religion, or national origin, or refuse to accredit a volunteer examiner on the basis (or lack thereof) of membership in an amateur radio organization.

Detailed qualifications of a VEC are contained in Subpart I of the Amateur Radio Service Rules (see Federal Register of October 6, 1983, Volume 48, pages 45652-45661). In order to serve as a VEC, an entity must be organized, at least partially, for the purpose of furthering amateur radio, and agree not to accept any compensation from any source for its services.

Proposals to become a VEC must contain the entity's qualifications; a showing concerning prevention of conflict of interest;

and a statement detailing how the examination program will be implemented in the region or regions for which the entity is applying to become a VEC.

The Commission's Field Office examination schedule, FO-28, December 1983, will remain effective for amateur radio operator examinations through 1984, and then amateur operator examinations at field offices will be discontinued.

### **Higher Power For 800 MHz Conventional And Trunked Stations At Four Sites In San Diego Proposed**

At the request of Motorola, Inc., the Commission proposed allowing 800 MHz conventional and trunked stations located on the mountaintop sites of Palomar, Otay, Woodson, and Miguel in San Diego, California to operate with an effective radiated power (ERP) of up to 500 watts.

The Commission pointed out that the power values developed for 800 MHz operations were based on a theoretical model of a typical station with average service area and terrain and did not take into account the unique characteristics of individual markets. When the FCC adopted the restrictions in 1974, it noted that it would make exceptions to the power values when system parameters differed substantially from those on which the model was based. It made such an exception for mountaintop sites in Los Angeles.

Motorola argued that the city of San Diego has evolved into an extensive metropolitan area covering irregular terrain with numerous peaks and valleys, and that the present power limits have resulted in serious coverage problems. It argued that the relief needed in San Diego is similar to that afforded Los Angeles, and that the maximum power limit should be raised to 500 watts.

Currently, the maximum permissible power for suburban systems is 500 watts for antenna heights of 500 feet or less above average terrain (HAAT). For urban or trunked systems the maximum permissible power is one kilowatt for antenna heights of 1000 feet or less. The maximum power permitted decreases as the station's antenna height increases above these base values.

The maximum ERP permitted for conventional stations located on Palomar (HAAT 2606 feet) is 35 watts and 140 watts for trunked stations. Otay's (HAAT 2258 feet) conventional stations may operate with 50 watts and trunked stations with 200 watts. For stations at the Woodson site (HAAT 1829 feet) the maximum ERP is 80 watts for conventional stations and 350 watts for trunked stations. At the Miguel site (HAAT 1867 feet) the maximum ERP is 350 watts, whether the station is conventional or trunked.

The Commission denied Motorola's request for increased power at the four sites on an interim basis because of the potential for interference to other stations in surrounding communities.

PC

## A SCANNER ANTENNA FOR THE "PROS"!!!

MODEL SC-3000

Butternut's patented "Trombone" phasing sections increase capture area and let you pull in the weak signals that aren't even there on conventional scanner antennas.

Covers 30 to 512 MHz

Gain: low range—unity  
VHF—up to 3 decibels  
UHF—up to 7 decibels

High-quality aluminum alloy and stainless steel hardware used throughout.

Wind survival: 100+ m.p.h.  
Height: 11 Feet  
Suggested Retail Price \$65.00

Dealer Inquiries Invited



**Butternut Electronics Co.**  
405 E. Market Street • Lockhart, Texas 78644

Please send all reader inquiries directly.

## Just in time for Christmas! The Most Accurate Clock A great gift idea!

The most accurate consumer clock ever made! The Heath GC-1000 Most Accurate Clock sets and corrects itself automatically by receiving shortwave broadcasts from the National Bureau of Standards. Microprocessor circuitry displays hours, minutes, seconds and even tenths of seconds. Kit priced at \$249.95. Send for complete details today using the coupon below. Visa and MasterCard orders call TOLL-FREE: 1-800-253-0570.



**FREE COLORFUL CATALOG**

Please send me my FREE Heathkit Catalog featuring the GC-1000 Most Accurate Clock and many other quality electronic kits.

Name \_\_\_\_\_

Address \_\_\_\_\_ Apt. \_\_\_\_\_

City \_\_\_\_\_

State \_\_\_\_\_ Zip \_\_\_\_\_

MAIL TO: Heath Company, Dept. 336-222  
CL-766 Benton Harbor, MI 49022

**Heathkit**  
Heath  
Company

# NRD-515 COMMUNICATIONS RECEIVER

GENERAL COVERAGE 100 KHz. to 30.0 MHz.

NOW THE ULTIMATE IS AFFORDABLE

**PRICE BREAKTHROUGH !!!**

**NRD-515 Receiver .1-30 MHz  
\$949.00**

**NDH-51896 Channel Memory  
\$235.00**

**NCM-515 Keypad Controller  
\$175.00**

**NVA-515 External Speaker  
\$45.00**



The NRD-515 offers more features and performance than any other receiver in its class. Exceptional selectivity and stability make this an excellent radio for RTTY and FAX reception. Designed for the serious DXer who demands the best!

For more information on this or other SWL products write to:

### UNIVERSAL SHORTWAVE RADIO

1280 Aida Drive  
Reynoldsburg, Ohio 43068  
Phone: 614-866-4267

Please send all reader inquiries directly.



## "INSIDER'S INFORMATION"

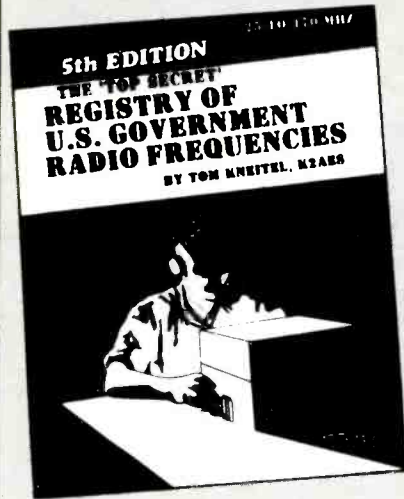

Since 1967, CRB Research has been the world's leading publisher and supplier of unique hobby and professional books and information including:

- Scanner Frequency Guides
- Shortwave Frequency Guides
- Military/Federal Communications
- Broadcast Station Registries
- Undercover Communications
- Survival Communications
- Covert Operations
- Electronic Espionage
- Surveillance
- Monitoring
- Cryptography & Codes
- Bugging
- Wiretapping
- Communications Antennas
- Electronics & Projects
- Authentic Combat Communications Cassettes
- Computer Technology
- & Other Related Topics!

New titles are constantly being added to our exciting catalog. If it's interesting and unusual, we've got it. You'll see! Ask for our latest FREE catalog!

**CRB RESEARCH**

P.O. Box 56 Commack, NY 11725

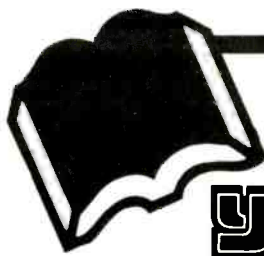

# BOOKS YOU'LL LIKE!

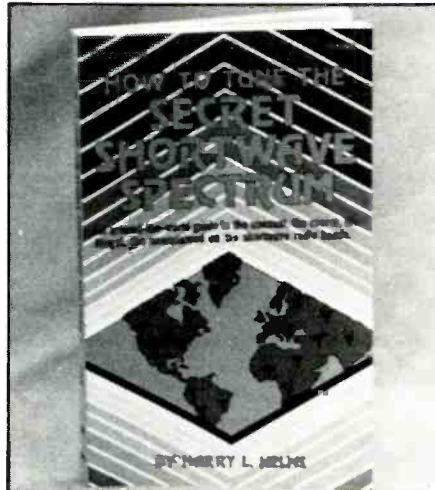

*How To Tune The Secret Shortwave Spectrum*, by "ute" authority Harry Helms, is a 182-page book on how to get the best results when monitoring those unknown signals which seem to come from nowhere—clandestines, spy stations, propaganda stations, diplomatic stations, pirates, government and military transmissions, and all others which lie far, far outside the realm of the usual or ordinary shortwave fare, such as international broadcasters. These strange and bizarre signals pervade the shortwave spectrum and Helms reveals how and where they operate, who operates them, and how to hear them for yourself. This unique book is not just a listing of stations and frequencies, but one which explains, in detail, about these stations in addition to giving frequencies. It is loaded cover-to-cover with charts, etc., plus a discussion of the many baffling issues that have been raised because of the existence and increasing presence of these stations operating in the secret shortwave spectrum.

*How To Tune The Secret Shortwave Spectrum* is available from CRB Research, P.O. Box 56, Commack, NY 11725 for \$7.95 plus \$1 postage/handling to USA/Canada/APO/FPO addresses. Other areas, \$7.95 for the book and \$4 for surface mail.

Home video is booming! Consumer electronics industry experts predict over 7-million VCRs will be sold in 1984.

That's why the information in HPBooks' new *How to Select & Use Home-Video Equipment* is so valuable! Authors Marjorie Costello and Michael Heiss, editors of *Videography* magazine, are experts in all phases of the video world.

Before consumers invest in any home

video equipment, they'll want to know what's new and what's coming. This book is the most current guide available.

The first-time buyer will learn terminology and find out what features are important. It compares VHS, Beta, and 8mm formats; tells how to buy a videocassette recorder (VCR), tuner/timer, camera, or camcorder; explains differences in videocassettes; and helps you select equipment to fit your needs and budget. The book also shows how to easily connect components, including different types of cable-TV and pay-TV hookups, and clears up the mystery of cables, connectors, and switches.

For those who already have home video equipment, this book provides a complete update to the latest products for 1984. It discusses Eastman Kodak's Kodavision, Sony and other new camcorders such as Beta-movie and JVC Video Movie.

Explanation is also offered on how to mix and match different brands of equipment, and lists who makes what brands. There are also useful tables, charts, and buying guides included throughout.

There are even hints on how to protect your investment by learning important maintenance techniques; which accessories you can obtain to add fun and ease to using your video equipment; and there are over 250 helpful illustrations.

This quality 160-page paperback is available wherever fine books are sold, or send check or money order for \$9.95 (\$12.95 Canada), plus \$1.95 postage & handling for each book, to: HPBooks, Box 5367, Tucson, AZ 85703. **PC**



## Beaming In (from page 4)

clubs as other editors in the past have done out of sheer frustration caused by a few wimp clubs.

Actually, it's almost a miracle that several worthwhile national monitoring clubs have managed to exist without falling into any of the ruts and ditches facing DX clubs. They've done exceptionally good jobs.

The newsletters that all SWL/DX/monitoring clubs produce, of course, tell the story. They are the most obvious outward manifestation of an individual group, projecting the philosophy, integrity, health, aims, membership quality, and even personality of the organization. Sometimes what they project is upbeat and great, and this helps to attract new members and keep the existing ones. Then, there are some publications that contain a lot of garbage and appear to be adequate representations of the groups for which they speak.

Those who produce the club newsletters and write the columns are serving on a voluntary basis. That means that they are expected to devote countless hours each month producing a column or else overseeing an entire publication without any financial reward. The dedication, knowledge, and efforts of many of these people is often heroic in scope. Unfortunately, there just aren't enough people willing to do this work whose efforts are up to snuff. Out of the many who are working on club newsletters, there just aren't enough folks like Spence Naylor (ASWLC), Stew MacKenzie (ASWLC), Mike Chabak (presently relinquishing his *SPEEDX* column), W. R. McIntosh (LWCA), Ken Cornell (LWCA), and maybe a dozen more whose efforts are outstanding. There are many others whose work is serviceable and credible. But, unfortunately, when a club is looking for volunteers to take on the work load of a column they sometimes have to settle for those whose knowledge, integrity, abilities, dedication, and motivations are mediocre or worse. This is where things get hairy.

The image of listeners in general can also suffer from some of the inept actions of those who function within the realm of clubs and their columns. One of our staff members once worked in the technical publications department of a large and very important electronics company. He recently told me a story which points out how this happens. One fellow who generates a lot of words within the field of shortwave, including a major column in a very respectable DX club publication, decided to gallop off on a senseless crusade against the electronics company in question. As part of this effort, he decided to take to task the shortwave receiver manuals offered by the company. Primarily, he said that he was annoyed that a list of shortwave broadcast stations in the manuals was outdated. Admittedly, this was a flimsy excuse from which to launch a crusade, but it was a start, and his comments went on further to state that everything the company of-

ferred for sale was junk. He urged that his readers write to the company's president to echo his gripes. They did write, but his campaign didn't accomplish anything of value. Many who wrote were nasty, sarcastic, and abusive—and they included the original squawks about how all of the company's products were junk, even though it's doubtful that any of the letter writers actually felt that way based upon their own personal experiences.

Frankly, there was no argument that the shortwave station listing in question was getting long in the tooth, but it was a standard "boilerplate" section of all of the company's receiver manuals and was in the process of being updated for a new line of receivers the company was readying for release. The company president observed that he wasn't sure if "those nuts" would be happy with anything the company did. As time went on, the company did back away from the previously strong emphasis they had once given to shortwave receivers. Properly approached, this company might well have been made into a strong ally of monitoring enthusiasts; instead, it was turned off at the highest level. Thanks a lot!

Readers will find that there are many benefits to joining one or more of the quality national groups in operation, and also joining a local or area-wide group (if one is in existence) where they live. But it does take some selectivity if you're going to get any real value for your dues and not just hook up with a group that isn't going to offer you anything of interest. Of course, your taste in clubs and their newsletters may well be very different than mine, and I can fully appreciate that some of the clubs I regard as being run by weirdos and cranks are obviously making some people happy. All I can do is point you towards those groups that I believe have been tops on an all-around basis

and have done well in avoiding the problems that normally face DX radio clubs. If I've slighted one or more of your personal favorites, I'm sorry. I did warn you that it might not be an easy visit this month.

Here are those national groups in the U.S.A. that I think are especially worthy of your support and membership:

*American Shortwave Listeners Club (ASWLC)*, 16182 Ballard Lane, Huntington Beach, CA 92649.

*The Association of Clandestine radio Enthusiasts (ACE)*, P.O. Box 452, Moorhead, MN 56560 (an especially good club covering pirates and spy stations).

*Association of North American Radio Clubs (ANARC)*, 1500 Bunbury Drive, North Whittier, CA 90601.

*Great Circle Shortwave Society (GCSS)*, P.O. Box 874, Kankakee, IL 60901.

*International Radio Club of America (IRCA)*, P.O. Box 26254, San Francisco, CA 94126 (covers only broadcast band DX).

*Longwave Club of America (LWCA)*, 45 Wildflower Rd., Levittown, PA 19057.

*National Radio Club (NRC)*, P.O. Box 128, Poquonok, CT 06064 (covers only broadcast band DX).

*North American Shortwave Association (NASWA)*, 45 Wildflower Rd., Levittown, PA 19057.

*SPEEDX*, 7738 East Hampton St., Tucson, AZ 85715.

Also, there was a group calling itself the Association of DX Reporters which started up about two years ago and looked to be heading in the right direction. However, they abruptly stopped sending us copies of their DX publication without any explanation. I don't know the present status of the ADXR, but this could possibly be a worthwhile group. It was formed by some former members of the defunct NNRC. Is this club still around? **PC**

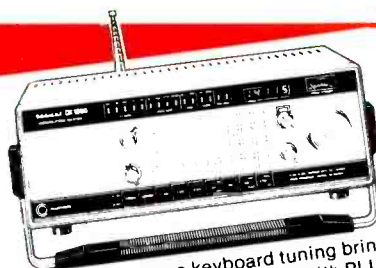

## Enjoy Direct Access To The World Bearcat DX-1000 shortwave radio.

Direct access keyboard tuning brings a new level of simplicity to shortwave radio. Covering 10 kHz to 30 MHz with PLL synthesized accuracy, the DX1000 has all the features even the most sophisticated shortwave "DXer" could want. 10 memory channels let you instantly recall favorite stations. A built-in timer wakes you to your favorite station, or activates equipment like a tape recorder to record programs while you are asleep or at work. The digital display measures frequencies to 1 kHz, or at the touch of a button, doubles as a two time zone, 24-hour digital quartz clock.

The DX-1000 also includes independent selectivity selection to help you separate high-powered stations on adjacent frequencies, plus a noise blanking system that stops Russian pulse radar interference. For world news. For exotic entertainment. For exciting DX probing. The Bearcat® DX-1000 gives you direct access to the world.

**BELDEN cable & antenna wire, METZ shortwave antennas, MCKAY DYMEK, AMECO preamplifiers.**  
CIRCLE 9 ON READER SERVICE CARD

**Call Toll Free 1-800-231-3057**

NIGHT NUMBERS 5-10 p.m. CST  
Mon., Wed., Fri. 1-800-231-1064  
INSIDE TEXAS 1-713-331-2235



**MADISON  
Electronics Supply**

Call for Quotes 713-658-0268  
We stock what we advertise, and much more.



# COMMUNICATIONS SHOP

PORTABLE AM BOOSTER ANTENNAS for distant mediumwave reception. Audio mixers and surplus radio parts. Save Dollars—Order Canadian! Eldon Electronic Enterprises, Box 713, Port Coquitlam, B.C., CANADA V3B 6H9.

EARN \$800+ WEEK! Get your "F.C.C. General Radiotelephone License." Fast, inexpensive! Electronics Home Study. Free details. Command, D-125, Box 2223, San Francisco, CA 94126.

220-400 MHZ MILITARY RECEIVER, R-978/GKA-5, tuneable, includes military data sheets, schematics, and USAF technician's notes on building small amplifier to receive voice. \$135 delivered, as I have no room for it. Weight 60 lbs. Tom Sanor, 4940 Bedell Rd., Roswell, GA 30075.

MOTOROLA-MONITOR, 154.130 MHz, excellent, 3-tone filters, 410.8 Hz, 330.5 Hz, 349.0 Hz, charger/ant. 1 yr on warranty. Will ship anywhere for P.O. money order for \$225.00. John R. Miller, 2450 Colony Loop, Anchorage, AK 99511 (907) 344-3375.

"FANTASTIC DISCOUNTS" ICR-71A \$689.50, Kenwood R-2000 \$499.50, Sony 2002 \$219.50, DX-1000 \$479.50, HX-1000-30ch \$239.50 IN STOCK!! MX-5000 \$388.50, Bearcat, CW/RTTY, MFJ, Panasonic, 25 Page Picture Catalog \$1.00 (refundable). Galaxy Electronics, Box-1202, 67 Eber Ave., Akron, Ohio 44309. (216-376-2402) 9:5pm EST.

ARMY RADIOS: CPRC-26 Infantry Manpack Radio, compact, transmits-receives 46-54 MHz FM, 6 channels, with battery box, antenna, crystal, handset. \$22.50 apiece, \$42.50/pair, good condition. PRC-510 Backpack Radio (Canadian version of American PRC-10), transmits-receives 38-55 MHz FM continuous tuning, with battery box, headset, antenna: \$39.50 apiece, \$77.50/pair, good condition. R-390A, premier communications Receiver, 5-30 MHz shortwave, amateur, military frequencies, AM-CW-SSB, meters sealed (Government removed, operation unaffected), fair condition: \$115, not checked; \$195, checked. R-108 Vehicular/Field Receiver, 20-28 MHz FM: \$27.50 mint. ARC-27 Guard Receiver, single channel 220-250 MHz aircraft: \$12.50 mint. 45 Day Replacement Guarantee. Add \$9.50 shipping-handling (except R-390A, shipped shipping charges collect). Baytronics, Dept. PC, Box 591, Sandusky, OH 44870.

MUST SELL. Midex 55 burglar alarm system in excellent condition. Works great. \$200.00 wanted. Send SASE or call (213) 599-8389. Mark Harvey, 2010 Cedar St., Apt. C, Long Beach, CA 90806.

SCANNER OPERATORS! Are you registered? Be assigned your own personal monitoring ID letters inscribed on beautiful 2-color bordered certificate. Thousands already registered! Only \$5, ppd. from CRB Research, Box 56PC, Commack, NY 11725.

WORLD'S MOST UNUSUAL Communications Books! A large selection of outstanding titles covering scanners, "confidential" frequency registries, bugging, wiretapping, electronic surveillance, covert communications, computers, espionage, monitoring, and more! New titles being added constantly! Ask for our large new FREE catalog. CRB Research, Box 56-PC, Commack, NY 11725.

**Advertising Rates:** Non-commercial ads are 30 cents per word including abbreviations and addresses; minimum charge \$6.00 per issue. Ads from firms offering commercial products or services are \$1.00 per word; minimum charge \$20.00 per issue. Leading key words set in all caps at no additional charge. All classified ads must be prepaid in full at time of insertion; a 5% discount is offered for prepaid 6 time insertions. All ads must be typewritten double spaced.

**Approval:** All ad copy is subject to Publisher's approval and may be modified to eliminate references to equipment and practices which are either illegal or otherwise not within the spirit or coverage scope of the magazine.

**Closing Date:** The 10th day in the third month preceding date of publication. Because the advertiser and equipment contained in Communications Shop have not been investigated, the Publisher of Popular Communications cannot vouch for the merchandise listed therein. Direct all correspondence and ad copy to: PC Communications Shop, 76 N. Broadway, Hicksville, NY 11801.

**POLICE & FIRE SCANNERS.** Special—Regency D-310, 30 Channel Digital Scanner \$129.99 plus \$4.00 shipping. See Our Full-Page Ad in This Issue for Complete Description. Free Catalog Available. SCANNER WORLD, USA, 10 New Scotland Ave., Albany, NY 12208, phone 518-436-9606.

**SOLAR ELECTRICITY.** Photovoltaic systems for remote power or emergency backup. Generate electricity by sunlight. Send \$1.00 (refundable with order) to Springhouse Energy Systems, 418 Washington Trust Building, Washington, PA 15301 (412) 225-8685.

**WANTED: OLD RCA, CUNNINGHAM, Western Electric, Genalex, tubes, speakers, amplifiers, McIntosh, Marantz.** 713-728-4343. Maury Corb, 11122 Atwell, Houston, Texas 77096.

**AIRPORT FREQUENCY DIRECTORIES.** Every known civil airport. Towers, Ground Control, FSS, Approach/Departure Control, Unicom, much more. \$3.00 Each: CA, FL, NY, PA, MI, OH, WI, OK, TX, KS, IL. All other states \$2.00 each. Specify state. Communications, Box 997, Las Vegas, NV 89125.

**S. W. L. REPORT FORMS** designated for maximum information your listening post. Give real meaning your D.X. reports. Details 2 IRC. Rout. 3/137 Champion St., Christchurch, New Zealand.

**ELECTRONIC SPYING** is the name of the game. It's also the title of a startling book which reveals the closely guarded methods & equipment used by professionals & amateurs who eavesdrop on homes & businesses with (sometimes) legal and (usually) illegal bugs & wiretaps. Written in non-technical language everyone can easily understand. **ELECTRONIC SPYING** has photos & illustrations clearly revealing exactly how they do it & where they get the equipment (much of it inexpensive & easily available). Leaves nothing to the imagination! Latest techniques covered & offers an in-depth wealth of information on the ever increasing electronic invasion unavailable from any other source. This book is used by law enforcement agencies as a reference manual. Only \$7.95 (plus \$1.00 postage) per copy from CRB Research, P.O. Box 56, Commack, N.Y. 11725.

**CLANDESTINE CONFIDENTIAL** keeps you up to date on the latest in clandestine broadcasting. 6 issues per year \$10 in the U.S., \$13 foreign. G.L. Dexter, RR4 Box 110, Lake Geneva, WI 53147.

**JOIN A RADIO listening club.** Complete information on major North American clubs for 25¢ and SASE. Association of North American Radio Clubs, 1500 Bunbury Drive, Whittier, CA 90601.

**CB RADIO MODIFICATIONS!** Increase channels, range, privacy. Conversion hardware, books, plans, kits, repairs. Catalog \$2. CBCL, Box 31500PC, Phoenix, AZ 85046.

**COMMUNICATIONS SECURITY. DECEPTION.** Tactics, Unbreakable Codes. New 40-page How-To-Manual. Detailed, Easy. \$11. Eustis Press, Suite 18, 751 Dunlap Circle, Winter Springs, FL 32708.

**FREE CATALOG** featuring scanner accessories, carrier/subcarrier detectors, voice scramblers, unusual kits. Capri Electronics, Route 1-GC, Canon, GA 30520 (404) 376-3712.

**NORTH AMERICAN RADIO-TV STATION GUIDE** by Vane Jones. Brand new 15th Edition! Thick 226-page book listing all US/Canadian/Mexican/West Indies AM/FM/TV broadcasters according to location/frequency/callsign, plus TV network affiliation, AM station day/nite power, schedule data, etc. Painstakingly complete, accurate, up-to-date. The ultimate broadcast station directory. Only \$9.95 (plus \$1 postage) from CRB Research, P.O. Box 56, Commack, NY 11725.

**LOWEST PRICES ON BEARCAT, REGENCY SCANNERS:** Trade-ins, Used Scanners at savings, Descramblers, Accessories. Free catalog! Spotlight Communications, Box 3047, Greenville, NC 27836-3047.

**FOR SALE:** Kenwood R-600 and R-1000 receivers. New... excellent condition. Upgrading listening post; must sell. Each shipped USPS free for \$225 and \$325 respectively. Also "hands-free" 49 MHz VOX transceivers. \$85 for pair. Write: SFC Harold Ort, Army PAO, 663 5th Avenue, New York, NY 10022. SASE for more info.

## Lightning Protectors

## For Antenna and AC Lines

### Transi-Trap™

R-T, HV  
Mark II Series

(also available with N-type connectors)

Ceramic gas tube protectors are super-fast-firing. Feature unique Arc-Plug™ cartridge and isolated ground. 50 ohm impedance. 200 watt models are most sensitive, best for RCVR's and XCVR's. Models R-T and HV offer special low loss performance through 500 MHz.



LT, HT



Model LT (200 W) . . . \$19.95  
Model HT (2 kW) . . . \$24.95  
Model R-T (200 W) . . . \$29.95  
Model HV (2 kW) . . . \$32.95

(Add \$2.00 for postage in U.S.)

See Data Sheet for surge limitations.

### Model MACC Master AC Control Console

Provides eight outlets and features lighted switches for individual circuits and master single-switch station control.



At your Alpha Delta dealer. Or order direct in U.S. MasterCard and VISA accepted.



## ALPHA DELTA COMMUNICATIONS, INC.

P.O. Box 571, Centerville, Ohio 45459 • (513) 435-4772



CIRCLE 57 ON READER SERVICE CARD

2-3R

# AD INDEX

## Coming Soon In POPULAR COMMUNICATIONS

**POPULAR COMMUNICATIONS**  
SEPTEMBER 1984 \$7.95  
\$5.00 CANADIAN

**War In The Mideast:  
Tune In On It!**



- Radio's Prophet Of Hate
- Cellular Mobile Communications
- United Nations Radio
- Operational Perspectives Of Spy Transmissions
- 175 Great Scanner Frequencies

**SURVIVAL!** Tom Kneitel's new *National Directory of Survival Radio Frequencies!* Unique book reveals the 5,000 most required radio frequencies 179 kHz to 470 MHz. State police, forestry, CD, highway maintenance, fish/game disaster, EMS, military, flood control, Indian Reservations, Air/Army National Guard, fed/state prisons, ports/harbors/bridges, clear channel broadcasters, severe weather, and lots more. National & state-by-state listings. An absolute must for every Survivalist and concerned citizen. A concise/handy key to knowing what's going on around you during a disaster or crisis, or for listening right now to hear what's taking place behind the scenes. Only \$7.95 by First Class Mail from CRB Research, P.O. Box 56, Commack, NY 11725.

"**RAIL-SCAN**" by Tom Kneitel. New scanner frequency directory! Largest & most comprehensive railroad industry communications directory ever! 4,200 frequencies, 863 major RR's, short lines, narrow gauge, government, miniature, movie, museum, scenic, industrial traction, mass transit lines, private car owners, RR police, car/locomotive builders & service companies, regulatory agencies, accident/emergency channels, RR addresses, trackage data, lots more. Only \$7.95 (add \$1 for 1st Class Mail). Order now or ask for free info. CRB Research, Box 56-PC, Commack, NY 11725.

**NEW! TOP SECRET REGISTRY OF U.S. GOV'T FREQUENCIES** by Tom Kneitel. Yes, it's finally here! The NEW 5th Edition is now 168 pages BIG in large 8 1/2" x 11" format (same page size as POP/COMM). Latest federal scanner frequency listings for FBI, FCC, Border Patrol, ATF, Immigration, Secret Service, CIA, Customs, Coast Guard, Armed Forces, and much more. Tens of thousands of call signs, frequencies, locations. The ultimate scanner directory also reveals many HF listings plus complete historic roster of all federal land stations authorized in 1923 (60 years ago)! New 5th Edition is \$14.95 postpaid by Book Rate Mail, or add \$2 if First Class Mailing wanted. Order your copy now! CRB Research, P.O. Box 56, Commack, NY 11725.

**WANTED: CASH PAID FOR USED SPEED RADAR EQUIPMENT.** Write or call: Brian R. Esterman, 735 Laramie Ave., Wilmette, Illinois 60091, (312) 251-8901.

**SIDEBAND OPERATORS!** Join the oldest/largest network of 27 MHz SSB operators. Now more than 100,000 strong! Send self-addressed stamped long (#10) envelope for FREE details and application (no obligation). SSB Network, P.O. Box 908, Smithtown, NY 11787.

All Electronics	23
Alpha Delta Communications	74
Arcomm	67
Auburn-Wolfe Pub. Co.	31
Barry Electronics	59
Brigade Quartermasters Ltd.	59
Bunker	45
Butternut Electronics Co.	71
CBC International	52
CRB Research	20, 72
Communications Elect.	2, 15
Computer Trader	67
DNE Inc.	52
Delaware Amateur Supply	48
EGE, Inc.	37
ESC Co.	65
Electra Co.	Cov. III
Electronic Equipt Bank	5, 91
Electronics Book Club	27
Fair Radio Sales	59
Gilfer Shortwave	34
Ham Shack	31
Hamtronics, Inc.	50
Heath Co.	71
ICOM America, Inc.	Cov. IV
Jensen Tools	65
Kentronics, Inc.	52
Kenwood	Cov. II
Litsche, N.E.	67
MFJ Enterprises, Inc.	4
Madison Electronics	73
Meshna Inc.	48
Metz Communication Corp.	53
Micro Mart	7
Missouri Radio Center	69
Miller Publishing	52
Morning Distributing	35
PopComm Book Shop	61
Radio West	59
Radio World	69
Research Electronics	53
Scanner World, USA	81
Spartan Supply Co. Inc.	65
Spectronics, Inc.	76
Spi-Ro Distributors	48
Telco	69
Unique Communications	57
Unity Electronics	67
Universal Electronics	35
Universal Security	52
Universal Shortwave Radio	23, 71
U. S. Calvary Store, Inc.	65
WRNO Radio	45
Westech Electronics	43
Western Radio	67
Worldwide Publications	57

## FREE FROM SPACE

More than  
50 channels  
of TV.

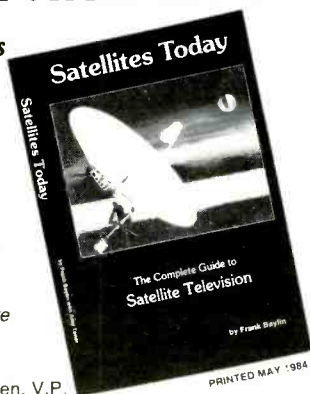

"Should be required reading for the entire industry".

Hal W. Farren, V.P.  
National Micro-Dynamics

### UPLINKS, SATELLITES & EARTH STATIONS LEGALITIES & PROGRAMMING THE PAST, PRESENT & FUTURE

To Order:  
Send \$9.95 for each  
copy of Satellites Today to  
ConSol Network, Box 12098-M  
Boulder, CO 80303

Name

Address

City

State

Zip

INQUIRE ABOUT OUR QUANTITY DISCOUNTS

## POPULAR COMMUNICATIONS

### Back Copies

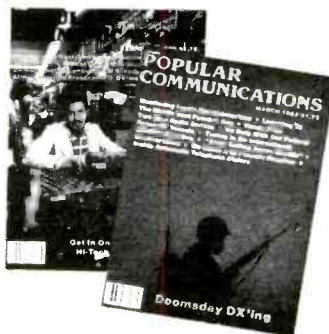

At present we have copies of all of our back issues available, commencing with the first issue (September '82). These can be ordered by mail at \$1.75 each from Popular Communications, 76 North Broadway, Hicksville, NY 11801. Be sure to specify which issues you want to order.

Reach this dynamic audience with your advertising message, contact either Herb Pressman, or Arnold Sposato, at (516) 681-2922.



# WE BOUGHT ALL THAT SONY HAD!



**FINAL CLOSEOUT!**

Reg. \$179.95  
Now only **\$96.50**  
plus \$3.00 UPS



## SONY ICF-6500W

"The 6500W performs on a par with models in the \$200-300 price range" (World Radio TV Handbook)

- Digital LCD display for accuracy
- Dual Conversion Superheterodyne
- BFO for SSB/CW • 1 uV Sensitivity
- AFC for FM • AC/DC power

**WHEN THEY'RE GONE, THEY'RE GONE!**  
Now is the time to buy, before they are all sold out. Sony doesn't have any more, and when our supply is exhausted, that's it. Buy one now and stash it away for Christmas!

## EXTRA SPECIAL OFFER

NEWSSTAND PRICE: \$23.00  
SUBSCRIPTION PRICE: \$14.00



Buy a Sony ICF-6500W and receive a year's subscription to Popular Communications magazine absolutely free!! This offer is good only until we sell out.

The new Sony ICF-2002 is here! From one of America's largest Sony SWL dealers.

Reg. \$249.95  
INTRODUCTORY SPECIAL  
**\$224.95**  
Plus \$3.00 UPS



**AVAILABLE NOW!**

## MAKE WAY FOR THE NEW LEADER IN SW!

After selling over 1,000 ICF-2001's we didn't think Sony could top this performer, but they did!

### FEATURES

Ten memory channels • 12/24 hour quartz clock • PLL tuning for drift-free performance • Dual conversion Superheterodyne for high sensitivity • SSB/CW

### SPECIFICATIONS

150 kHz-30 MHz AM, 76-108 MHz FM • 1 uV sensitivity @ 6 dB S/N @ 10 MHz • 72 dB @ 10 MHz image ratio • 3 kHz @ -6 dB

## SONY AN1 ACTIVE ANTENNA

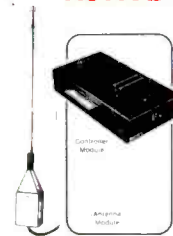

- 100KHZ-30MHz
- Remote 59 inch Telescoping Whip
- Battery or Optional AC Powered

**\$7995**  
+ \$3.00 UPS

When you're stuck in an apartment with no other choice, this may just be the answer. The unique design offers numerous mounting & hook up options. You will be surprised how well it works.

SONY		PANASONIC	
AN1	\$ 79.95 + (\$ 3 UPS)	RF9	\$ 87.00 + (\$2 UPS)
ICR4800	69.95 (\$ 2 UPS)	RFB50	129.00 (\$2 UPS)
ICF6800W	549.95 (\$10 UPS)	RFB300	219.00 (\$3 UPS)
AC9W	12.00 (\$ 2 UPS)	RFB600	499.95 (\$9 UPS)
AC160W	14.00 (\$ 2 UPS)	RF799	229.95 (\$3 UPS)
DCC127	29.50 (\$ 2 UPS)	RF1405	69.95 (\$3 UPS)
AC120	11.00 (\$ 2 UPS)	RF3100	279.00 (\$5 UPS)

Shipping charges in parenthesis are for continental U.S. only. International orders write for pro forma invoice. Illinois residents please add 7% sales tax.

**Phone: (312) 848-6777**

ICOM		PUBLICATIONS	
ICR71	\$739.00 (\$9 UPS)	(\$2 UPS 1st book, ea additional book add 50¢ UPS)	
BEARCAT		World Radio TV Handbook, 1984 Edition	\$17.50
DX1000	\$529.00 (\$9 UPS)	SWL Manual of Non Broadcast Stations	12.95
AMECO		How to Tune the Secret Shortwave Spectrum	7.95
PLF2 Preamp	\$57.95 (\$3 UPS)	The Complete Short Wave Listeners Handbook	11.95
EAVESDROPPER		Short Wave Listeners Antenna Handbook	9.95
SWL Dipole	\$59.95 (\$3 UPS)	Whites Radio Log	4.95
MFJ			
1020	\$79.95 (\$2 UPS)		
752B	89.95 (\$3 UPS)		
304	79.95 (\$2 UPS)		
308	99.95 (\$2 UPS)		



**SPECTRONICS, INC.**  
1009 GARFIELD ST. OAK PARK, IL. 60304

Spectronics Proudly Sponsors  
"Radio Earth" which can be heard at 03:00 GMT on 6.185 MHz seven days a week.



# CRIME.

# DETECTOR



# REBATE.

Like a smoke detector protects you from fire, a Uniden® Bearcat® Scanner Radio is a simple way to help protect you from neighborhood crime. Because if a crime wave hits, you'll be the first to know about it with up-to-the-minute police reports. And you'll be ready to take precautions against the kind of people who do their shopping at night.

**Get up to \$50 back on Uniden® Bearcat® Scanners.** To get the rebate on the Uniden® Bearcat® Scanner you've purchased, send: (1) original dated sales slip (non-returnable), (2) purchase confirmation cut from carton flap, and (3) this completed request to: Crime Detector Rebate, P.O. Box 50208, Indianapolis, Indiana 46256.

Please circle the scanner purchased:

- |                          |                        |
|--------------------------|------------------------|
| (1) BC-300/\$50 Rebate   | (9) BC-200/\$10 Rebate |
| (2) BC-210XL/\$25 Rebate | (10) BC-180/\$5 Rebate |
| (3) BC-100/\$25 Rebate   | (11) BC-155/\$5 Rebate |
| (4) BC-20/20/\$20 Rebate | (12) BC-151/\$5 Rebate |
| (5) BC-250/\$20 Rebate   | (13) BC-5-6/\$5 Rebate |
| (6) BC-220/\$20 Rebate   | (14) BC-5/\$5 Rebate   |
| (7) BC-260/\$15 Rebate   | (15) BC-15/\$5 Rebate  |
| (8) BC-201/\$15 Rebate   |                        |

First Initial      Middle Initial      Last Name

Address

City      State      Zip

Requests must be postmarked by December 8, 1984. Offer valid only on purchase made between October 1, 1984 and November 25, 1984. All requests must be postmarked by December 8, 1984. Limit of one Uniden® Bearcat® Scanner per household, and/or consumer, regardless of number of Uniden® Bearcat® Scanners purchased. This is a consumer rebate offer only. Resellers, companies and employees of Uniden® their advertising agencies, distributors and retailers are not eligible. This official coupon must accompany all requests, and may not be reproduced. This offer may not be used in conjunction with any other rebate offer from Uniden® Bearcat®. Offer good only in U.S.A. Void where taxed or prohibited by law. Allow 6-8 weeks for delivery of check.

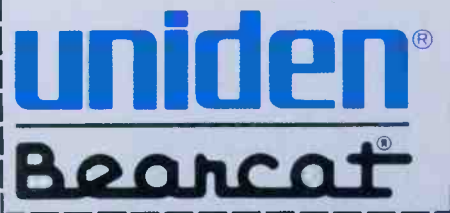

Uniden® provides major financial support to the Neighborhood Crime Prevention Coordinating Committee.  
© 1984 Uniden Corporation of America



# ICOM IC-751

## The New Standard of Comparison

IC-2KL  
Solid-state  
Linear  
Amplifier

IC-AT500  
Automatic  
Antenna Tuner

IC-SP3  
External  
Speaker

IC-SM6  
Desk Mic

The IC-751 is the most advanced amateur HF transceiver available on the market today... the new standard of comparison.

**Receiver.** ICOM's 100kHz — 30MHz general coverage receiver with a specially designed DFM (Direct Feed Mixer) utilizes FETs in the receiver front end which gives extremely low intermodulation distortion,  $\pm 19$ dBm intercept point, and a high dynamic range, 105dB. With cascaded filters, the IC-751 is virtually immune

to RF overload. The FL-44 8-pole crystal in the third IF is standard and provides exceptional receiver selectivity.

**Transmitter.** An extremely low-noise PLL and conservative transmitter design give extremely low distortion products ( $-38$ dBm, third order) for a crystal clear transmit signal. A microphone tone control is provided to personalize the set to your particular voice. The 9 band solid-state transmitter is also a full 100% duty cycle

(internal cooling fan standard) rated. For the CW operator, semi break-in or full QSK is possible.

**32 Memories.** An ultra versatile memory system allows storage of frequency and mode in each of the 32 memories. Data may be transferred from VFO to memory or from memory to VFO.

**Standard Features.** FM, FL-44A 455kHz high-grade SSB filter, SSB and FM squelch, built-in marker unit, convenient large controls, a new high-visibility fluorescent

display and HM-12 Hand Mic.

### Options and Accessories.

Voice synthesizer, high stability master reference crystal, a wide range of CW filters, an external IC-PS15 or PS30 power supply, an internal IC-PS35 power supply, CT-10 computer interface unit, RC10 keyboard frequency controller, IC-2KL solid-state linear amplifier (160 — 15 meters), IC-AT500 automatic antenna tuner, IC-SP3 external speaker and IC-SM6 desk mic.



### IC-PS30 System Power Supply.

The IC-PS30 25 Amp Switching Power Supply consolidates your power requirements by supplying up to four pieces of ICOM equipment, eliminating the need for independent AC power supplies for each. The IC-PS30 is designed to match all of ICOM's amateur equipment.

 **ICOM**  
The World System

CIRCLE 25 ON READER SERVICE CARD

ICOM America, Inc., 2112-116th Ave NE, Bellevue, WA 98004 / 3331 Towerwood Drive, Suite 307, Dallas, TX 75234

All stated specifications are approximate and subject to change without notice or obligation. All ICOM radios significantly exceed FCC regulations limiting spurious emission. 751484